



Southeast
TOO**L**

VOLUME 10

To manufacture quality tooling
you need the best machinery.



Southeast Tool, Inc.

OUR MISSION STATEMENT

1. To satisfy the customers needs.
2. To provide the highest quality tooling available at the most competitive price.
3. To help and assist the customer with custom manufactured tooling and application issues as well.
4. To trouble shoot and solve the problem.

TERMS AND CONDITIONS OF SALES

Terms: All accounts will be given Net 30-day terms if credit is deemed satisfactory by the credit department. A 1-1/2% service charge will be added to all accounts past due. Any account over 60 days will be placed on credit hold until the account is brought current. All invoices correspond with date of shipment, not receipt of goods or invoice. **A \$25.00 service charge will be added for all returned checks. A \$15.00 service charge will be added for all invoices paid by wire transfer.** Southeast Tool, Inc. sells only through a vast network of distributors world wide. Please call or e-mail for the one in your area. Prices subject to change without notice.

Freight Policy: F.O.B. Conover NC. Any shortages in transit should be filed with the carrier. Any other shortages should be filed with Southeast Tool, Inc. no more than 10 days after receiving goods. Catalog orders over \$500.00 net will be shipped free ground freight prepaid within the continental USA; this excludes truck shipments.

Drop Shipments: All drop shipments are subject to regular terms and minimum order requirements. COD drop shipments will not be accepted.

Product Guarantee: All tools are warranted to be free from defects in workmanship. Due to the inherent nature of solid carbide, we cannot guarantee this material. **All warranties are void if tools are altered in any way (including sharpening).**

Returning Goods: All returns must be given prior consent by the company. A RGA # will be issued and must be clearly placed on the outside of the package. Southeast Tool, Inc. reserves the right to charge a 20% restocking fee. A copy of the invoice must also accompany the return. This applies to tools ordered in error and returned for exchange. Any tool returned for credit must be a current catalog item and must be returned in original packaging and in resalable condition. The correct tool must have been ordered or an off setting order placed. **No tools will be accepted for return after one year from date of purchase.** Southeast Tool, Inc. assumes no liability for returned goods. It is the shipper's responsibility to package the tools in a manner as to avoid damage in transit. Returned freight must be prepaid.

Orders: Orders must be a **minimum of \$50.00 net.** Orders may be placed with Southeast Tool, Inc. by phone, fax, mail, internet, or e-mail. Since orders are processed continually throughout the day, add-ons to orders cannot be guaranteed to ship with other orders that have already been processed.

Special Tooling: Because of the vast resources of Southeast Tool, Inc., we can quote on almost any cutting tool that you or your customer may need. Please send a detail sketch or wood sample for a quotation. You may also e-mail drawings or photos to **quotes@southeasttool.com.** To expedite the quote please include the following: cutting diameter, cutting length, shank diameter, overall length, number of flutes, cutting rotation (i.e. RH or LH). We reserve the right to consider an order complete with 20% over or under ordered quantity. **Specials are not subject to return or cancellation.** Custom tooling may require a deposit prior to manufacturing. Although every effort is made to produce specialty tooling to a customer's specific needs. Any defects must be noted in writing to Southeast Tools, Inc. within 120 days of invoice date

Safety: Always wear eye and ear protection when working with cutting tools. Do not remove any machine safety guards. The grinding of carbide produces hazardous dust that may be harmful to your health; please use precautions and proper ventilation. Always wash hands before eating or drinking anything after handling carbide products.

Table of Contents

Accessories

Bearings & Screws	49
Carving Bits	51
Corner Chisel	51
Diamond Wheels.....	150
Hollow Mortising Bits	50
Inlay Kit	48
Lubricates	34, 156
Router Blanks.....	50
Router Table Pods.....	150
Steel Collets	48
Template Guide Kit.....	48

Boring Bits

Carbide-Tipped Brad Point Bits	115-116, 119
Carbide-Tipped V-Point Bits	116-117
Carbide-Tipped Hinge Bits	117-118
Carbide-Tipped Countersinks, Counterbores	121
Chuck Adapters.....	120
Solid Carbide Drill & Adapters	118-119,121

Laminate Bits

Double End Flush & Bevel Bits	1
Easy Edge Bits.....	154
Flush & 7° Bevel Trim Bits.....	1
Flush Trim & Euro™ Flush Trim Bits	27-28, 30, 31
Glue Space Bits.....	155

Carbide-Tipped Straight Bits

1 Flute Bits.....	13
2 Flute Bits.....	13-15
Dovetail Bits	21, 155
Flush Trim & Euro™ Flush Trim Bits.....	27-28, 30
Glue Space Bits.....	155
High Speed Steel Panel Pilot Bits.....	153
Left-hand Bits	15
Mortising Bits	16
Panel Pilot Bits	22
Staggertooth Bits	15, 21
Template Bits	18, 29

Carbide-Tipped Profile Bits

Ball Cutting Bits	18
Beaded Picture Frame Bit.....	40
Beauty Molding Bit.....	40
Bowl & Tray Bits	17
Bullnose (Half Round) Bits	18
Chamfer/ Bevel Bits	26-27, 32

Core Box Bits	17
Cove Bits	22, 35, 36
Crown Molding Edge Trim	40
Door Edge Profile Bits.....	40
Double Round Bits	26, 36
Edge Beading Bits	36
Edge Detail Bits.....	22-35, 44
Ellipse Ogee Bits	41
Euro Step Bits.....	154
Furniture/Box Maker Bit	41
Handrail Bit	38
Keyhole Bits	29
Molding Bits.....	37-38
Multi-Form Bits.....	38
Ogee Bits	36, 42
Ogee Fillet Bits.....	36
Picture Frame Bits.....	154
Plywood Bits	45
Point Cutting Bits	20
Rabbet/Slotting Bits	23
Roundnose Bits	17
Roundover Bits.....	24
Roundover Beading Bits	25
Roundover Plunge Bits.....	24-25
Roman Ogee Bits	26
Table Edge Bits	37
Triple Bead & Triple Flute Bits.....	35
T-Slot Bits.....	30
V-Groove Bits.....	19-20
Wavy Edge Bits	35

Carbide-Tipped Solid Surface Bits

Bevel Undermount Bits	32
Drainboard Bits	33
Face Cove & Backsplash Cove Bits.....	33
Face Inlay Bits.....	31
No Drip Bits	31,33
Overhang Bits	31
Rounding Over & Rounding Under Bits.....	31-32
Roman Ogee Undermount Bits	32
Solid Surface Repair Bits	155
Surface Planer Bits	33
Wilsonart™ Bowl Bits.....	34

Carbide-Tipped Glue/Joining Bits

Drawer Lock Bits	39
Finger Joint Bits	41
Glue Joint Bits.....	39
Lock Miter Bits	39
MDF Door Bits.....	42

Table of Contents

Raised Panel Bits	43		
Stile & Rail Bits	44		
Tongue & Groove Bits	39,41		
Window Sash Bits	45		
Collets & Toolholders			
Accessories	112		
Analog Axial Preset Gauge	155		
Collet Nut Wrenches	105		
ER Collets	103		
ER Collet Nuts	104		
ER Tool Extenders	107		
Height Gauge	155		
Heian® Collets	104		
Hydraulic Tool Holders	108		
Reducing Sleeves for Hydraulic Tool Holders	108		
ISO, SK, BT30 & BT35 Toolholders	106-108		
ISO, HSK Type F Arbors	110		
Mini Nuts	109		
Pull Studs	109		
Shoda® Collets & Nuts	102		
SYOZ 20 & 25 Collets & Nuts	101		
TG Collets	104		
Tightening Stands	110		
Wipers & Brushes	111		
Counterbores/Countersinks			
Counterbores	56-57, 59-60, 63-64, 67		
Countersinks	55, 58-63, 65-66		
Diamond Tooling			
Diamond 1+1 Straight Bits	100		
Diamond T-Slot Bits	100		
Door Drills & Bits			
3 Wing Drills	52		
Brad Point Twist Drills	54		
Door Bits	52-53, 98		
Economy Door Drills	54		
Face Frame Bits	54, 153-154		
Forstner Bits	99		
HSS Spiral Door Bits	98		
Insert Drill Bits	98		
Latch Boring Bits	54		
Multi-Spur HSS & Carbide-Tipped Bits	53		
Quick Change Drills	52		
Spade Bits	99		
Drills			
Auger Bits	92-94		
Brad Point Drills	58, 65, 68-84		
Chucks (threaded)	96-97		
Depth Collars	96		
Jobber Drill Bits	85-87, 89		
Plastic Drill	94		
Plug Cutters	67		
Self Centering Guides (Vix)	95		
Silver & Deming® Bits	91		
Straight Shank Drills	58, 62, 65-66, 68-69,		
Stubby Length Drills	88		
Taper Point Drills	90		
Threaded Shank Drills	63-64, 68, 70-76		
Vibrating Mortise Bits	64		
S/C Insert Knives/STB Strips			
Polished Solid Carbide Knives	45		
Solid Carbide Inserts (ICK)	129-134		
STB Strips	138		
Insert Tooling			
Cope & Stick Tooling	125-126		
Cope & Stick Cutters	127		
Raised Panel Cutters	127-128		
Router Bits	123-124		
Spoil Board Cutters	125		
Molder/Planer			
Corrugated Back HSS Molder Steel	136		
HSS & C/T Planer Knives	145-146		
Molder Heads	137		
Superpac™ Knives and Backing Plates	149		
Spiral Plus Molder Heads	135		
Tersa™, Terminus™, Centrollock™	147-148		
William & Hussey™ Steel	136		
Paso Robles Throw Away Bits			
Throw Away Flush Trim Bits	153		
Throw Away Template Bits	153		
Throw Away Bevel Trim Bits	153		
Throw Away Rabbet Bits	153		
Throw Away Straight Bits	153		
Replacement Cutters	153		
Accessory Replacements	153		

Table of Contents

S/C Plastic Cutting Bits/Saw

C/T Plastic Saw & Arbor	4
O-Flute (1 Flute and 2 Flutes) Bits	2-3
O-Flute Spiral Bits	2-3
Polished Multi-Grind Upcut O-Flute Bits	4
Radius O-Flute Bits	4
Solid Carbide Straight Bits	4-5

Slotting Cutter/Saw Blades

2, 3 & 4 Wing Slot Cutters	46
2, 3 & 4 Wing Slot Cutters Assemblies	46
Carbide-Tipped Saw Blades	151
Drawer Slot Cutters	47
Flush Bottom Slot Cutters	47
Topmaster Slot Cutters	47

Solid Carbide Bits

Double End Flush & Bevel Bits	1
Fiberglass Bits	1
Flush & 7° Bevel Trim Bits	1
Hole, Flush Trim, Rip & Slotting Bits	1
Round Bottom Veining Bits	1
Veining Bits	1
V-Grooving Bits	1

Solid Carbide Spiral Bits

2 Flute RH Spiral Bits	6
2 Flute Chipbreaker Bits	6
3 Flute Spiral Bits	7
3 Flute Chipbreaker Bits	7
3 Flute Ruffers	7
3 Flute Slow Spiral Bits	8, 34
3 Flute Slow Spiral Ruffers	7
4 Flute Finisher/Ruffers	11
Ball Nose Spiral Bits	12
Compression Spiral Bits 1+1	8
Compression Spiral Bits 2+2	8-9, 10
Compression Spiral Bits 3+3	11
Compression Spiral Bits 4+4	11
Compression Sprial Finisher/Ruffers 4+4	12
Left-Hand Spiral Bits	8, 10
Liner Bits	12
Mortise Compression Bits	9-10
Ruffer Spiral Bits	7
Slow Spiral Ruffer Bits	7
Spiral Flush Trim Bits W/ Bearings	5, 34
Tapered Ball Nose Bits	12

Solid Saw Tips

CWA	139
CWB	139
CWC	139
CWD	139
CWE	139, 140
CWF	140
CWG	140, 141
CWH	141
CWQ	141
CWD Right	141
CWD Left	141
CWG Right	141
CWG Left	142
WA	142
WB	142
WC	142
WD	142
WE	143
WF	143
WG	143, 144
WQ	144

Steel Items

Hollow Mortising Bits	50
Panel Pilot Bits HSS	153
Router Blanks	50

Sets

Basic Sets	IBC
Door Sets	IBC
Plastic Sets	IBC
CNC Sets	IBC
Display	IBC

Solid Carbide Bits

FLUSH TRIM BITS



SCF200

Part Number	Cutting Diameter	Cutting Length	Shank Diameter	Overall Length
SCF200	1/4"	1/4"	1/4"	1-1/2"
SCF203	1/4"	3/8"	1/4"	1-1/2"
SCF205	1/4"	3/8"	1/4"	2"



FLUSH TRIM BITS

Small Pilot for Shallow Dado



SCD210

Part Number	Cutting Diameter	Cutting Length	Overall Length	
SCD210	1/4"	1/4"	1-1/2"	Flush
SCD215	1/4"	1/4"	1-1/2"	7 Degree

7° BEVEL TRIM BITS W/PILOT



SCB220

Part Number	Cutting Diameter	Cutting Length	Shank Diameter	Overall Length
SCB220	1/4"	1/4"	1/4"	1-1/2"
*SCB220LH	1/4"	1/4"	1/4"	1-1/2"

*Left Hand Rotation

FLUSH & 7° BEVEL TRIM BITS



SCFB230

Part Number	Cutting Diameter	Cutting Length	Shank Diameter	Overall Length
SCFB230	1/4"	3/8"	1/4"	1-1/2"

ROUND BOTTOM VEINING BITS

1/4" SHANK, 1 FLUTE



SCRV273

Part Number	Radius	Cutting Diameter	Cutting Length	Overall Length
SCRV271	1/16"	1/8"	1/4"	1-1/2"
SCRV273	1/8"	1/4"	1/4"	2"

ROUND BOTTOM VEINING BITS

1/4" SHANK, 2 FLUTE



SCRV279

Part Number	Radius	Cutting Diameter	Cutting Length	Overall Length
SCRV275	1/16"	1/8"	5/16"	2"
SCRV277	3/32"	3/16"	3/8"	2"
SCRV279	1/8"	1/4"	3/8"	2"

FLAT BOTTOM VEINING BITS

2 FLUTE



SST198

Part Number	Cutting Diameter	Cutting Length	Shank Diameter	Overall Length
SST195	3/32"	5/16"	1/4"	1-1/2"
SST198	1/8"	1/4"	1/4"	2"

SOLID CARBIDE FIBERGLASS BITS



SCFB110

Part Number	Cutting Diameter	Cutting Length	Overall Length	
SCFB100	1/4"	3/4"	2-1/2"	End Mill End
SCFB110	1/4"	3/4"	2-1/2"	Plunge V Pt End
SCFB120	3/8"	7/8"	2-1/2"	End Mill End
SCFB130	3/8"	7/8"	2-1/2"	Plunge V Pt End
SCFB140	1/2"	1"	3"	End Mill End
SCFB150	1/2"	1"	3"	Plunge V Pt End

HOLE & FLUSH TRIM BITS



SCHF240

Part Number	Cutting Diameter	Cutting Length	Shank Diameter	Overall Length
SCHF240	1/4"	5/16"	1/4"	2"
SCHF242	1/4"	3/8"	1/4"	1-1/2"
SCHF244	1/4"	1/4"	1/4"	1-1/2"

RIP & SLOTTING BITS



SCRS250

Part Number	Cutting Diameter	Cutting Length	Shank Diameter	Overall Length
SCRS250	1/4"	3/8"	1/4"	1-1/2"

V-GROOVING BITS, 1/4" SHANK



SCVG260

Part Number	Cutting Diameter	Cutting Length	Overall Length	Degree
SCVG260	1/4"	1/8"	1-1/2"	90°
SCVG264	1/4"	7/32"	1-1/2"	60°
SCVG264-212	1/4"	7/32"	2-1/2"	60°

FLUSH & 7° BEVEL TRIM BITS

(Double-ended)



SCF200DB

Part Number	Cutting Diameter	Cutting Length	Shank Diameter	Overall Length
SCF200DB	1/4"	1/4"	1/4"	2" Flush
SCB220DB	1/4"	1/4"	1/4"	2" Bevel

1

2

3

4

5

6

7

8

9

10

Solid Carbide Plastic Cutting Bits

For Both Hard and Soft Plastics

O-FLUTE TOOLS FOR PLASTIC, 1 FLUTE

Part Number	Cutting Diameter	Cutting Length	Shank Diameter	Overall Length
SPL100	1/8"	3/8"	1/4"	2-1/2"
NEW SPL102	1/8"	1/2"	1/4"	2"
SPL103	1/8"	5/8"	1/4"	4"
SPL105	5/32"	1/2"	1/4"	2-1/2"
SPL110	3/16"	1/2"	1/4"	2-1/2"
NEW SPL111	3/16"	5/8"	1/4"	2"
SPL113	3/16"	1"	1/4"	4"
SPL115	7/32"	5/8"	1/4"	2-1/2"
SPL120	1/4"	3/4"	1/4"	2-1/2"
SPL125	1/4"	1"	1/4"	3-1/2"
SPL128	1/4"	1-1/4"	1/4"	4"
SPL130	3/8"	1"	3/8"	3"
NEW SPL134	3/8"	1-5/8"	3/8"	6"
SPL140	1/2"	1"	1/2"	3"
NEW SPL148	1/2"	2-1/8"	1/2"	6"



O-FLUTE TOOLS FOR PLASTIC, 2 FLUTE

Part Number	Cutting Diameter	Cutting Length	Shank Diameter	Overall Length
SPL210	1/8"	1/2"	1/4"	2"
SPL212	1/8"	5/8"	1/4"	4"
SPL213	5/32"	1/2"	1/4"	2-1/2"
SPL215	3/16"	3/8"	1/4"	2"
NEW SPL216	3/16"	5/8"	1/4"	2"
SPL217	3/16"	1"	1/4"	4"
SPL220	1/4"	1"	1/4"	2-1/2"
SPL222	1/4"	1"	1/4"	3-1/2"
SPL223	1/4"	1-1/4"	1/4"	4"
SPL225	3/8"	7/8"	3/8"	2-1/2"
SPL227	3/8"	1"	3/8"	4"
SPL230	1/2"	1"	1/2"	3"
SPL232	1/2"	1"	1/2"	4"



SOLID CARBIDE O-FLUTE TOOLS FOR PLASTIC, 1 FLUTE, LH ROTATION

Part Number	Cutting Diameter	Cutting Length	Shank Diameter	Overall Length
SPL100LH	1/8"	3/8"	1/4"	2-1/2"
NEW SPL105LH	5/32"	1/2"	1/4"	2-1/2"
SPL110LH	3/16"	1/2"	1/4"	2-1/2"
SPL120LH	1/4"	3/4"	1/4"	2-1/2"



SOLID CARBIDE O-FLUTE SPIRALS, 1 FLUTE

General Purpose

Upcut Part #	Downcut Part #	Cutting Diameter	Cutting Length	Shank Diameter	Overall Length
SOU100	SOD200	1/8"	3/8"	1/4"	2-1/2"
SOU110	SOD210	3/16"	1/2"	1/4"	2-1/2"
SOU120	SOD220	1/4"	3/4"	1/4"	2-1/2"
SOU123	SOD223	1/4"	1-1/4"	1/4"	3"
SOU135	SOD235	3/8"	1"	3/8"	3"
SOU136	SOD236	3/8"	1-5/8"	3/8"	3-1/2"
SOU160	SOD260	1/2"	1-5/8"	1/2"	3-1/2"



Solid Carbide Plastic Cutting Bits

For Both Hard and Soft Plastics

NEW

SOLID CARBIDE O-FLUTE SPIRALS, 1 FLUTE *Hard Plastics*



SOU323

Upcut Part #	Downcut Part #	Cutting Diameter	Cutting Length	Shank Diameter	Overall Length
SOU300	N/A	1/8"	1/4"	1/4"	2"
SOU302	SOD402	1/8"	1/2"	1/4"	2"
SOU311	N/A	3/16"	3/8"	1/4"	2"
SOU313	SOD413	3/16"	5/8"	1/4"	2"
SOU320	N/A	1/4"	3/8"	1/4"	2"
SOU323	SOD423	1/4"	3/4"	1/4"	2-1/2"
SOU326	SOD426	1/4"	1-1/4"	1/4"	3"
SOU332	N/A	3/8"	5/8"	3/8"	2-1/2"
SOU335	SOD435	3/8"	1-1/8"	3/8"	3"
SOU338	N/A	3/8"	1-5/8"	3/8"	3-1/2"
SOU345	SOD445	1/2"	1-5/8"	1/2"	3-1/2"

NEW

SOLID CARBIDE O-FLUTE SPIRALS, 1 FLUTE *Soft Plastics*



SOU523

Upcut Part #	Downcut Part #	Cutting Diameter	Cutting Length	Shank Diameter	Overall Length
SOU500	N/A	1/8"	1/4"	1/4"	2"
SOU502	SOD602	1/8"	1/2"	1/4"	2"
SOU511	N/A	3/16"	3/8"	1/4"	2"
SOU513	SOD613	3/16"	5/8"	1/4"	2"
SOU520	N/A	1/4"	3/8"	1/4"	2"
SOU523	SOD623	1/4"	3/4"	1/4"	2-1/2"
SOU526	SOD626	1/4"	1-1/4"	1/4"	3"
SOU532	N/A	3/8"	5/8"	3/8"	2-1/2"
SOU535	SOD635	3/8"	1-1/8"	3/8"	3"
SOU538	N/A	3/8"	1-5/8"	3/8"	3-1/2"
SOU545	SOD645	1/2"	1-5/8"	1/2"	3-1/2"

NEW

O-FLUTE Slow Spiral Upcut Spiral 2 Flute



SOU723

Upcut Part #	Downcut Part #	Cutting Diameter	Cutting Length	Shank Diameter	Overall Length
SOU720	N/A	1/4"	3/8"	1/4"	2-1/2"
SOU723	SOD823	1/4"	3/4"	1/4"	2-1/2"
SOU734	N/A	3/8"	1"	3/8"	3"
SOU742	N/A	1/2"	1-1/8"	1/2"	3-1/2"
SOU745	N/A	1/2"	1-5/8"	1/2"	3-1/2"
SOU748	N/A	1/2"	2-1/8"	1/2"	4-1/2"

NEW

O-FLUTE Upcut Spiral 2 Flute



SOU920

Part Number	Cutting Diameter	Cutting Length	Shank Diameter	Overall Length
SOU920	1/4"	3/8"	1/4"	2-1/2"
SOU926	1/4"	1-1/4"	1/4"	3"
SOU934	3/8"	1"	3/8"	3"
SOU937	3/8"	1-1/2"	3/8"	4"
SOU943	1/2"	1-1/4"	1/2"	4"
SOU948	1/2"	2-1/8"	1/2"	4"

Solid Carbide Plastic Cutting Bits

For Both Hard and Soft Plastics

POLISHED MULTI-GRIND

1

O-FLUTE, 1 Flute



SPOU120

Part Number	Cutting Diameter	Cutting Length	Shank Diameter	Overall Length
SPOU100	1/8"	1/2"	1/4"	2-1/2"
SPOU110	3/16"	5/8"	1/4"	2-1/2"
SPOU120	1/4"	3/4"	1/4"	2-1/2"

2

SOLID CARBIDE RADIUS O-FLUTE, 1 Flute & 2 Flute



SPR220

1 Flute Part Number	2 Flute Part Number	Cutting Diameter	Cutting Length	Overall Length	Radius	Opening	Material	Sm Dia
SPR200	SPR300	1/4"	3/8"	2-1/2"	1/8"	5/32"	1/8"	.195
SPR210	SPR310	1/4"	3/8"	2-1/2"	3/16"	7/32"	3/16"	.180
SPR220	SPR320	1/4"	3/8"	2-1/2"	1/4"	9/32"	1/4"	.163

3

NEW

SOLID CARBIDE RADIUS O-FLUTE SPIRAL 1 Flute



SPR400

Part Number	Cutting Diameter	Cutting Length	Overall Length	Radius	Opening	Material	Sm Dia
SPR400	1/4"	3/8"	2-1/2"	1/8"	5/32"	1/8"	.195
SPR410	1/4"	3/8"	2-1/2"	3/16"	7/32"	3/16"	.180
SPR420	1/4"	3/8"	2-1/2"	1/4"	9/32"	1/4"	.163

4

CARBIDE TIPPED PLASTIC SAW (TRIPLE CHIP GRIND)

Suggested Feed



SPS2-16-095

Part Number	Cutting Diameter	Wings	Hook	Kerf	Bore	RPM	Feed (IPM)
SPS2-16-095	2"	16	0°	.095	5/8"	18,000	125 to 175
SPS25-16-095	2-1/2"	16	0°	.095	5/8"	16,000	125 to 175
SPS3-16-095	3"	16	0°	.095	5/8"	14,000	125 to 175
SPS35-16-095	3-1/2"	16	0°	.095	5/8"	12,000	125 to 175

6

ARBORS FOR PLASTIC SAWS



SPSARBOR-12

Part Number	Arbor Diameter	Shank Diameter	Overall Length
SPSARBOR-12	1-1/4"	1/2"	3-1/4"
SPSARBOR-12-412	1-1/4"	1/2"	4-1/2"
SPSARBOR-58	1-1/4"	5/8"	3-1/4"
SPSARBOR-34	1-1/4"	3/4"	3-1/4"

7

Solid Carbide Straight Cut Bits

SOLID CARBIDE, 1 FLUTE STRAIGHT BITS



SST120

Part Number	Cutting Diameter	Cutting Length	Shank Diameter	Overall Length
SST100	1/16"	1/4"	1/4"	1-1/2"
NEW SST110	1/8"	3/8"	1/4"	1-1/2"
SST120	1/4"	3/4"	1/4"	2"
SST130	1/4"	1"	1/4"	2-1/2"

9

10

Solid Carbide Straight Cut Bits

SOLID CARBIDE, 2 FLUTE STRAIGHT BITS

For plastics or wood

Part Number	Cutting Diameter	Cutting Length	Shank Diameter	Overall Length
SST195	3/32"	5/16"	1/4"	1-1/2"
SST198	1/8"	1/4"	1/4"	2"
SST200	1/8"	3/8"	1/4"	2"
SST203	1/8"	3/8"	1/4"	1-1/2"
SST205	5/32"	3/8"	1/4"	2"
SST207	5/32"	3/8"	1/4"	1-1/2"
SST210	3/16"	1/2"	1/4"	2"
SST213	3/16"	1/2"	1/4"	1-1/2"
NEW SST214	3/16"	5/8"	1/4"	2"
SST215	7/32"	3/4"	1/4"	2"
SST220	1/4"	3/4"	1/4"	2"
SST223	1/4"	3/4"	1/4"	2-1/2"
SST225	1/4"	1"	1/4"	2-1/2"
SST230	1/4"	1"	1/4"	3"
SST235	5/16"	1"	5/16"	2-1/2"
SST240	3/8"	1"	3/8"	2-1/2"
NEW SST241	3/8"	1"	3/8"	3"
SST245	3/8"	1-1/4"	3/8"	3"
SST250	1/4"	3/4"	1/2"	3"
SST255	5/16"	1"	1/2"	3"
SST260	3/8"	1"	1/2"	3"
SST265	1/2"	1-1/8"	1/2"	3"
SST270	1/2"	1-1/4"	1/2"	3"
SST275	1/2"	1-5/8"	1/2"	3-1/2"
SST280	1/2"	2"	1/2"	4"



SST245

NEW

NEW

1

2

3

4

5

6

7

8

9

10

Micro-Grain Solid Carbide Spiral Bits

SPIRAL FLUSH TRIM BIT, 2 FLUTE

Upcut Part Number	Downcut Part Number	Cutting Diameter	Cutting Length	Shank Diameter	Overall Length
SFTU120	SFTD220	1/4"	1"	1/4"	3"
SFTU155	SFTD255	1/2"	1-1/4"	1/2"	3-1/2"
SFTU165	SFTD265	1/2"	2"	1/2"	4-1/2"



SFTU120



SFTUD555

SPIRAL FLUSH TRIM BIT COMPRESSION, 2+2

Part Number	Cutting Diameter	Cutting Length	Shank Diameter	Overall Length
SFTUD555	1/2"	1-1/4"	1/2"	4"

REPLACEMENT BEARINGS 1/4" BITS SBE100

1/2" BITS SBE145

REPLACEMENT RINGS 1/4" BITS SE-E25

1/2" BITS SE-E12

Micro-Grain Solid Carbide Spiral Bits

2 FLUTE RIGHT-HAND ROTATION

Upcut Part Number	Downcut Part Number	Cutting Diameter	Cutting Length	Shank Diameter	Overall Length
SRU102	SRD202	3/32"	1/2"	1/4"	2"
SRU103	SRD203	1/8"	1/2"	1/4"	2"
SRU105	SRD205	5/32"	3/4"	1/4"	2"
SRU110	SRD210	3/16"	3/4"	1/4"	2"
NEW SRU113	SRD213	5MM	3/4"	1/4"	2"
SRU115	SRD215	7/32"	3/4"	1/4"	2"
SRU118	SRD218	1/4"	3/4"	1/4"	2-1/2"
SRU120	SRD220	1/4"	1"	1/4"	2-1/2"
SRU123	SRD223	1/4"	1-1/4"	1/4"	3"
NEW N/A	SRD224A	9/32"	1"	5/16"	2-1/2"
NEW N/A	SRD224B	9/32"	1"	3/8"	2-1/2"
SRU124	SRD224	9/32"	1"	1/2"	3"
SRU125	SRD225	5/16"	1"	5/16"	3"
SRU130	SRD230	5/16"	1"	1/2"	3"
SRU135	SRD235	3/8"	1"	3/8"	3"
SRU137	SRD237	3/8"	1-1/4"	3/8"	3"
SRU145	SRD245	3/8"	1-1/4"	1/2"	3"
NEW N/A	SRD250A	7/16"	1"	1/2"	3"
SRU150	SRD250	7/16"	1-1/4"	1/2"	3"
SRU153	SRD253	1/2"	1"	1/2"	3"
SRU155	SRD255	1/2"	1-1/4"	1/2"	3"
SRU160	SRD260	1/2"	1-5/8"	1/2"	3-1/2"
SRU163	SRD263	1/2"	1-3/4"	1/2"	4"
SRU165	SRD265	1/2"	2"	1/2"	4"
SRU167	SRD267	1/2"	2-1/8"	1/2"	4"
SRU169	SRD269	17/32"	1-1/4"	1/2"	3-1/2"
SRU170	SRD270	9/16"	1-1/4"	1/2"	3"
SRU175	SRD275	5/8"	1-1/2"	5/8"	3-1/2"
SRU180	SRD280	5/8"	2"	5/8"	4"
SRU185	SRD285	3/4"	1-1/2"	3/4"	4"
SRU190	SRD290	3/4"	2"	3/4"	4"
NEW SRU191	SRD291	3/4"	2-1/8"	3/4"	4"
NEW SRU192	SRD292	3/4"	2-1/2"	3/4"	5"
SRU193	SRD293	3/4"	3"	3/4"	6"
SRU195	SRD295	3/4"	3-1/4"	3/4"	6"
SRU197	SRD297	3/4"	3-1/2"	3/4"	6"



SRD255

CHIPBREAKER 2 FLUTE RIGHT-HAND ROTATION

Best selling chipbreaker tools

Upcut Part Number	Downcut Part Number	Cutting Diameter	Cutting Length	Shank Diameter	Overall Length
SRU137CB	SRD237CB	3/8"	1-1/4"	3/8"	3"
SRU155CB	SRD255CB	1/2"	1-1/4"	1/2"	3"
SRU160CB	SRD260CB	1/2"	1-5/8"	1/2"	3-1/2"
SRU165CB	SRD265CB	1/2"	2"	1/2"	4"
SRU167CB	SRD267CB	1/2"	2-1/8"	1/2"	4"
SRU180CB	SRD280CB	5/8"	2"	5/8"	4"
SRU190CB	SRD290CB	3/4"	2"	3/4"	4"
SRU193CB	SRD293CB	3/4"	3"	3/4"	6"

Chipbreakers can be added to any solid carbide bit, by adding CB to end of part number: SRU160CB



SRD260CB

**SOLID CARBIDE IS NOT GUARANTEED AGAINST BREAKAGE.
SHARPENING SERVICE IS AVAILABLE FROM SOUTHEAST TOOL, CALL FOR PRICES.**

Micro-Grain Solid Carbide Spiral Bits

3 FLUTE RIGHT-HAND ROTATION

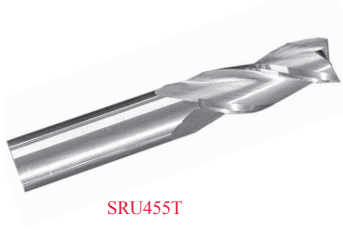

SRU455T

Upcut Part Number	Downcut Part Number	Cutting Diameter	Cutting Length	Shank Diameter	Overall Length
SRU440T	SRD540T	3/8"	1-1/4"	3/8"	3"
SRU455T	SRD555T	1/2"	1-1/4"	1/2"	3"
SRU460T	SRD560T	1/2"	1-5/8"	1/2"	3-1/2"
SRU465T	SRD565T	1/2"	2"	1/2"	4"
SRU480T	SRD580T	5/8"	2"	5/8"	4"
SRU485T	SRD585T	3/4"	1-1/2"	3/4"	4"
SRU490T	SRD590T	3/4"	2"	3/4"	4"
SRU495T	SRD595T	3/4"	3"	3/4"	6"

CHIPBREAKER 3 FLUTE RIGHT-HAND ROTATION

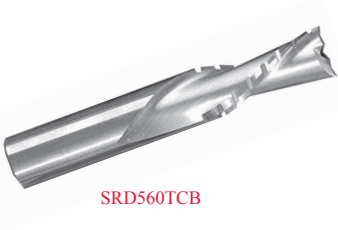

SRD560TCB

Upcut Part Number	Downcut Part Number	Cutting Diameter	Cutting Length	Shank Diameter	Overall Length
SRU440TCB	SRD540TCB	3/8"	1-1/4"	3/8"	3"
SRU455TCB	SRD555TCB	1/2"	1-1/4"	1/2"	3"
SRU460TCB	SRD560TCB	1/2"	1-5/8"	1/2"	3-1/2"
SRU465TCB	SRD565TCB	1/2"	2"	1/2"	4"
SRU480TCB	SRD580TCB	5/8"	2"	5/8"	4"
SRU485TCB	SRD585TCB	3/4"	1-1/2"	3/4"	4"
SRU490TCB	SRD590TCB	3/4"	2"	3/4"	4"
SRU495TCB	SRD595TCB	3/4"	3"	3/4"	6"

RUFFER 3 FLUTE SPIRALS ~ Hoggers



SRD460RUF

Upcut Part Number	Downcut Part Number	Cutting Diameter	Cutting Length	Shank Diameter	Overall Length
* SRU320RUF	SRD420RUF	3/8"	7/8"	3/8"	2-1/2"
SRU340RUF	SRD440RUF	3/8"	1-1/4"	3/8"	3"
SRU346RUF	SRD446RUF	3/8"	1-3/4"	3/8"	4"
SRU350RUF	SRD450RUF	1/2"	1-1/4"	1/2"	3"
SRU360RUF	SRD460RUF	1/2"	1-1/2"	1/2"	3-1/2"
SRU368RUF	SRD468RUF	1/2"	1-3/4"	1/2"	4"
SRU370RUF	SRD470RUF	1/2"	2"	1/2"	4"
SRU367RUF	SRD467RUF	1/2"	2-1/4"	1/2"	4"
SRU380RUF	SRD480RUF	5/8"	2"	5/8"	4"
SRU390RUF	SRD490RUF	3/4"	2"	3/4"	4"
NEW SRU392RUF	SRD492RUF	3/4"	2-1/2"	3/4"	5"
SRU393RUF	SRD493RUF	3/4"	3"	3/4"	6"
SRU395RUF	SRD495RUF	3/4"	3-1/4"	3/4"	6"
NEW SRU397RUF	SRD497RUF	3/4"	3-1/2"	3/4"	6"

*For Castle Machine.

NEW RUFFER 3 FLUTE SLOW SPIRALS ~ Hoggers



SRU523SLRUF

Upcut Part Number	Downcut Part Number	Cutting Diameter	Cutting Length	Shank Diameter	Overall Length
SRU513SLRUF	SRD613SLRUF	3/8"	1-1/4"	3/8"	3"
N/A	SRD614SLRUF	3/8"	1-1/4"	3/8"	3-1/2"
SRU523SLRUF	N/A	1/2"	1-1/8"	1/2"	3-1/2"
N/A	SRD625SLRUF	1/2"	1-1/4"	1/2"	3-1/2"
N/A	SRD626SLRUF	1/2"	1-1/2"	1/2"	4"
SRU527SLRUF	SRD627SLRUF	1/2"	1-5/8"	1/2"	4"
SRU528SLRUF	N/A	1/2"	1-3/4"	1/2"	4"
SRU534SLRUF	N/A	5/8"	1-5/8"	5/8"	4"
SRU537SLRUF	SRD637SLRUF	5/8"	2-1/8"	5/8"	5"
SRU542SLRUF	N/A	3/4"	1-5/8"	5/8"	4"
SRU545SLRUF	SRD645SLRUF	3/4"	2"	3/4"	5"

**SOLID CARBIDE IS NOT GUARANTEED AGAINST BREAKAGE.
SHARPENING SERVICE IS AVAILABLE FROM SOUTHEAST TOOL, CALL FOR PRICES.**



Micro-Grain Solid Carbide Spiral

Great for Problem Applications

3 FLUTE SLOW SPIRAL RIGHT-HAND ROTATION



Ucput Part Number	Downcut Part Number	Cutting Diameter	Cutting Length	Shank Diameter	Overall Length
SRU602SL	SRD702SL	1/4"	1"	1/4"	2-1/2"
NEW SRU611SL	N/A	3/8"	3/4"	3/8"	3"
SRU613SL	SRD713SL	3/8"	1-1/4"	3/8"	3"
NEW SRU621SL	N/A	1/2"	3/4"	1/2"	3"
NEW SRU623SL	N/A	1/2"	1-1/8"	1/2"	3"
NEW N/A	SRD724SL	1/2"	1-1/8"	1/2"	3-1/2"
SRU625SL	SRD725SL	1/2"	1-1/4"	1/2"	3"
SRU626SL	SRD726SL	1/2"	1-1/2"	1/2"	3-1/2"
SRU627SL	N/A	1/2"	1-1/2"	1/2"	4"
NEW N/A	SRD728SL	1/2"	1-5/8"	1/2"	4"
SRU629SL	SRD729SL	1/2"	1-3/4"	1/2"	4"
SRU645SL	SRD745SL	3/4"	2"	3/4"	4"
NEW SRU648SL	N/A	3/4"	3"	3/4"	6"

2 FLUTE LEFT-HAND ROTATION



Ucput Part Number	Downcut Part Number	Cutting Diameter	Cutting Length	Shank Diameter	Overall Length
SLU300	SLD400	1/8"	1/2"	1/4"	2"
SLU310	SLD410	3/16"	3/4"	1/4"	2"
SLU315	SLD415	7/32"	3/4"	1/4"	2"
SLU320	SLD420	1/4"	1"	1/4"	2-1/2"
SLU325	SLD425	5/16"	1"	5/16"	3"
SLU330	SLD430	3/8"	1"	3/8"	3"
SLU335	SLD435	7/16"	1-1/4"	1/2"	3"
SLU340	SLD440	1/2"	1-1/4"	1/2"	3"
SLU345	SLD445	1/2"	1-1/2"	1/2"	3-1/2"
SLU350	SLD450	1/2"	2"	1/2"	4"
SLU355	SLD455	5/8"	1-1/2"	5/8"	3-1/2"
SLU360	SLD460	5/8"	2"	5/8"	4"
SLU365	SLD465	3/4"	1-1/2"	3/4"	4"
SLU370	SLD470	3/4"	2"	3/4"	4"

1+1 COMPRESSION (UP-DOWN) SPIRALS RIGHT-HAND ROTATION



Part Number	Cutting Diameter	Cutting Length	Shank Diameter	Overall Length
SUD500	1/4"	1"	1/4"	2-1/2"
SUD505	3/8"	1-1/4"	3/8"	3"
NEW * SUD506	3/8"	1-1/4"	3/8"	3"
SUD509	1/2"	1-1/8"	1/2"	3"
SUD510	1/2"	1-1/4"	1/2"	3"
SUD512	1/2"	1-3/8"	1/2"	3-1/2"
NEW SUD515	1/2"	1-5/8"	1/2"	3-1/2"
SUD531	5/8"	2-1/8"	5/8"	4"



2+2 COMPRESSION (UP-DOWN) SPIRALS RIGHT-HAND ROTATION



Part Number	Cutting Diameter	Cutting Length	Shank Diameter	Overall Length
* SUD448	1/4"	1"	1/4"	2-1/2"
NEW * SUD460	5/16"	1-1/4"	5/16"	3"
NEW * SUD462	5/16"	1"	5/16"	3"
* SUD550	3/8"	1-1/4"	3/8"	3"
NEW * SUD551	3/8"	1-1/4"	3/8"	3"
* SUD551A	3/8"	1-1/2"	3/8"	3"
NEW * SUD553	1/2"	1"	1/2"	3"
SUD553A	1/2"	1"	1/2"	3-1/2"

*3/16" Upcut For Mortise Cuts

Continued on next page

Micro-Grain Solid Carbide Spiral

Continued from previous page

2+2 COMPRESSION (UP-DOWN) SPIRALS RIGHT-HAND ROTATION



SUD560

Part Number	Cutting Diameter	Cutting Length	Shank Diameter	Overall Length
NEW SUD554	1/2"	1-1/8"	1/2"	3"
SUD555	1/2"	1-1/4"	1/2"	3"
* SUD557	1/2"	1-1/4"	1/2"	3"
SUD560	1/2"	1-3/8"	1/2"	3-1/2"
SUD565	1/2"	1-5/8"	1/2"	3-1/2"
* SUD567	1/2"	1-5/8"	1/2"	3-1/2"
SUD570	1/2"	1-5/8"	1/2"	4"
NEW SUD571	1/2"	1-3/4"	1/2"	4"
SUD573	1/2"	2"	1/2"	4"
SUD575	5/8"	1-1/2"	5/8"	4"
SUD580	5/8"	2"	5/8"	4"
SUD585	3/4"	1-1/2"	3/4"	4"
SUD590	3/4"	2"	3/4"	4"
NEW SUD592	3/4"	2-1/2"	3/4"	4"
SUD594	3/4"	3"	3/4"	6"

*3/16" Upcut For Mortise Cuts

NEW 2+2 COMPRESSION (UP-DOWN) SPIRALS RIGHT-HAND ROTATION CHIPBREAKER



SUD560

Part Number	Cutting Diameter	Cutting Length	Shank Diameter	Overall Length
* SUD448CB	1/4"	1"	1/4"	2-1/2"
SUD462CB	5/16"	1"	5/16"	3"
* SUD550CB	3/8"	1-1/4"	3/8"	3"
SUD551CB	3/8"	1-1/4"	3/8"	3"
* SUD551ACB	3/8"	1-1/2"	3/8"	3"
* SUD553CB	1/2"	1"	1/2"	3"
SUD553ACB	1/2"	1"	1/2"	3-1/2"
SUD554CB	1/2"	1-1/8"	1/2"	3"
* SUD555CB	1/2"	1-1/4"	1/2"	3"
SUD557CB	1/2"	1-1/4"	1/2"	3"
SUD560CB	1/2"	1-3/8"	1/2"	3-1/2"
* SUD565CB	1/2"	1-5/8"	1/2"	3-1/2"
SUD567CB	1/2"	1-5/8"	1/2"	3-1/2"
SUD570CB	1/2"	1-5/8"	1/2"	4"
SUD571CB	1/2"	1-3/4"	1/2"	4"
SUD573CB	1/2"	2"	1/2"	4"
SUD575CB	5/8"	1-1/2"	5/8"	4"
SUD580CB	5/8"	2"	5/8"	4"
SUD585CB	3/4"	1-1/2"	3/4"	4"
SUD590CB	3/4"	2"	3/4"	4"
SUD592CB	3/4"	2-1/2"	3/4"	4"
SUD594CB	3/4"	3"	3/4"	6"

*3/16" Upcut For Mortise Cuts

2+2 MORTISE COMPRESSION BITS RIGHT-HAND ROTATION, 3/16" UPCUT



SUD557

Part Number	Cutting Diameter	Cutting Length	Shank Diameter	Overall Length
SUD448	1/4"	1"	1/4"	2-1/2"
NEW SUD460	5/16"	1-1/4"	5/16"	3"
NEW SUD462	5/16"	1"	5/16"	3"
SUD551	3/8"	1-1/4"	3/8"	3"
SUD553	1/2"	1"	1/2"	3"
SUD553A	1/2"	1"	1/2"	3-1/2"
SUD557	1/2"	1-1/4"	1/2"	3"

Micro-Grain Solid Carbide Spiral

1



SMDUD560

→ Designed with special carbide and grinding angles for high wear applications.

2



SMDUD555-316

→ Designed with special carbide and grinding angles for high wear applications.

3



SRD255MD

→ Designed with special carbide and grinding angles for high wear applications.

4

5

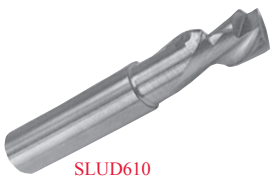

SLUD610

6



SLUD665

7



8

9

10

2+2 COMPRESSION SPIRAL – MD

MD Section Tools are for MDF and Laminates

Part Number	Cutting Diameter	Cutting Length	Shank Diameter	Overall Length
SMDUD550	3/8"	1-1/4"	3/8"	3"
SMDUD554	1/2"	1-1/8"	1/2"	3"
SMDUD555	1/2"	1-1/4"	1/2"	3"
SMDUD560	1/2"	1-3/8"	1/2"	3-1/2"
SMDUD565	1/2"	1-5/8"	1/2"	3-1/2"
NEW SMDUD571	1/2"	1-3/4"	1/2"	3-1/2"
SMDUD573	1/2"	2"	1/2"	4"

2+2 MORTISE COMPRESSION BIT – MD, 3/16" UPCUT

Part Number	Cutting Diameter	Cutting Length	Shank Diameter	Overall Length
SMDUD551	3/8"	1-1/4"	3/8"	3"
NEW SMDUD554A	1/2"	1-1/8"	1/2"	3"
SMDUD557	1/2"	1-1/4"	1/2"	3"
SMDUD567	1/2"	1-5/8"	1/2"	3-1/2"

2 FLUTE RIGHT-HAND ROTATION – MD

Upcut Part Number	Downcut Part Number	Cutting Diameter	Cutting Length	Shank Diameter	Overall Length
SRU120MD	SRD220MD	1/4"	1"	1/4"	2-1/2"
SRU135MD	SRD235MD	3/8"	1"	3/8"	3"
NEW N/A	SRD237MD	3/8"	1-1/4"	3/8"	3"
SRU155MD	SRD255MD	1/2"	1-1/4"	1/2"	3"
SRU160MD	SRD260MD	1/2"	1-5/8"	1/2"	3-1/2"
SRU165MD	SRD265MD	1/2"	2"	1/2"	4"

1+1 COMPRESSION (UP-DOWN) SPIRALS LEFT-HAND ROTATION

Part Number	Cutting Diameter	Cutting Length	Shank Diameter	Overall Length
SLUD598	1/4"	1"	1/4"	2-1/2"
SLUD600	3/8"	1-1/4"	3/8"	3"
SLUD605	1/2"	1-1/4"	1/2"	3"
SLUD610	1/2"	1-1/2"	1/2"	3-1/2"
SLUD615	1/2"	2"	1/2"	4"

2+2 COMPRESSION (UP-DOWN) LEFT-HAND ROTATION

Part Number	Cutting Diameter	Cutting Length	Shank Diameter	Overall Length
NEW SLUD648	1/4"	1"	1/4"	2-1/2"
SLUD650	3/8"	1-1/4"	3/8"	3"
SLUD655	1/2"	1-1/4"	1/2"	3"
SLUD665	1/2"	1-5/8"	1/2"	3-1/2"
SLUD673	1/2"	2"	1/2"	4"
SLUD675	5/8"	1-1/2"	5/8"	4"
SLUD680	5/8"	2"	5/8"	4"
SLUD685	3/4"	1-1/2"	3/4"	4"
SLUD690	3/4"	2"	3/4"	4"
NEW SLUD696	3/4"	2-1/2"	3/4"	5"

SOLID CARBIDE IS NOT GUARANTEED AGAINST BREAKAGE.
SHARPENING SERVICE IS AVAILABLE FROM SOUTHEAST TOOL, CALL FOR PRICES.

Micro-Grain Solid Carbide Spiral Bits

Chipbreakers can be added to any solid carbide bit, by adding CB to end of part number: SUD750CB



SUD765

3+3 COMPRESSION (UP-DOWN) RIGHT-HAND ROTATION, 3 FLUTES UP + 3 FLUTES DOWN

Part Number	Cutting Diameter	Cutting Length	Shank Diameter	Overall Length
SUD750	3/8"	1-1/4"	3/8"	3"
NEW *SUD751	3/8"	1-1/4"	3/8"	3"
NEW SUD754	1/2"	1-1/8"	1/2"	3"
SUD755	1/2"	1-1/4"	1/2"	3"
NEW *SUD756	1/2"	1-1/4"	1/2"	3"
SUD765	1/2"	1-5/8"	1/2"	3-1/2"
NEW SUD790	3/4"	2"	3/4"	4"

*3/16" Upcut For Mortise Cuts



SUD870

NEW 3+3 COMPRESSION SPIRAL – MD

Part Number	Cutting Diameter	Cutting Length	Shank Diameter	Overall Length
*SMDUD751	3/8"	7/8"	3/8"	3"
SMDUD750	3/8"	1-1/4"	3/8"	3"
*SMDUD756	3/8"	1-1/4"	3/8"	3"
SMDUD755	1/2"	1-1/4"	1/2"	3"
*SMDUD790	1/2"	1-1/4"	1/2"	3"

*3/16" Upcut For Mortise Cuts

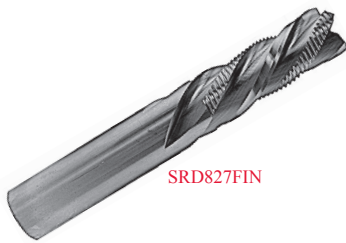

SRD827FIN

NEW 4 FLUTE RIGHT-HAND ROTATION – Finisher / Ruffer

Upcut Part Number	Downcut Part Number	Cutting Diameter	Cutting Length	Shank Diameter	Overall Length
SRU723FIN	SRD823FIN	1/2"	1-1/8"	1/2"	3-1/2"
SRU727FIN	SRD827FIN	1/2"	1-5/8"	1/2"	4"
SRU730FIN	SRD830FIN	1/2"	2-1/8"	1/2"	4-1/2"
N/A	SRD836FIN	5/8"	2-1/8"	5/8"	5"
SRU746FIN	SRD846FIN	3/4"	2-1/8"	3/4"	5"

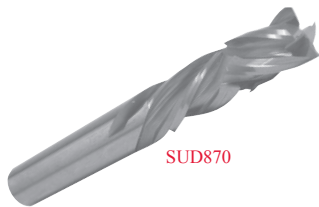

SUD870

NEW 4+4 COMPRESSION (UP-DOWN)

Part Number	Cutting Diameter	Cutting Length	Shank Diameter	Overall Length
SUD840	1/2"	7/8"	1/2"	3"
SUD842	1/2"	1"	1/2"	3"
SUD844	1/2"	1-1/8"	1/2"	3"
SUD860	1/2"	1-3/8"	1/2"	3-1/2"
SUD870	1/2"	1-5/8"	1/2"	4"
SUD885	3/4"	1-7/8"	3/4"	4"
SUD888	3/4"	2-1/2"	3/4"	5"

*All tools available with chipbreakers.

**SOLID CARBIDE IS NOT GUARANTEED AGAINST BREAKAGE.
SHARPENING SERVICE IS AVAILABLE FROM SOUTHEAST TOOL, CALL FOR PRICES.**

Micro-Grain Solid Carbide Spiral Bits

NEW 4 + 4 COMPRESSION – FINISHER / RUFFER

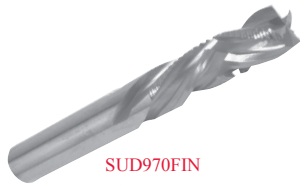

Part Number	Cutting Diameter	Cutting Length	Shank Diameter	Overall Length
SUD950FIN	1/2"	1"	1/2"	3"
SUD955FIN	1/2"	1-1/8"	1/2"	3"
SUD960FIN	1/2"	1-3/8"	1/2"	3-1/2"
SUD970FIN	1/2"	1-5/8"	1/2"	4"
SUD980FIN	3/4"	1-7/8"	3/4"	4"
SUD990FIN	3/4"	2-1/2"	3/4"	5"

SOLID CARBIDE LINER BIT FOR CARVING MACHINE



10 Degree

Part Number	Small Cutting Diameter	Shank Diameter	Overall Length
SLIN062	1/16"	1/4"	2-1/2"

SOLID CARBIDE BALL NOSE - UPCUT 2 FLUTE



Part Number	Cutting Diameter	Cutting Length	Shank Diameter	Overall Length
SBNU125	1/8"	1/2"	1/4"	2"
SBNU316	3/16"	3/4"	1/4"	2-1/2"
SBNU250	1/4"	3/4"	1/4"	2-1/2"
SBNU375	3/8"	1"	3/8"	3"
SBNU500	1/2"	1-1/4"	1/2"	3"
SBNU750	3/4"	2"	3/4"	4"

NEW SOLID CARBIDE TAPERED BALL NOSE - UPCUT 3 FLUTE



Part Number	Cutting Diameter	Cutting Length	Overall Length	Shank	Radius	Angle
STBNU125-1	1/8"	1-1/2"	3"	1/4"	1/16"	1 deg.
STBNU125-3	1/8"	1"	3"	1/4"	1/16"	3 deg.
STBNU125-5	1/8"	3/4"	3"	1/4"	1/16"	5 deg.
STBNU125-7	1/8"	1/2"	3"	1/4"	1/16"	7 deg.
STBNU250-3	1/4"	2"	4"	1/2"	1/8"	3 deg.
STBNU250-5	1/4"	1-3/8"	4"	1/2"	1/8"	5 deg.
STBNU250-7	1/4"	1"	4"	1/2"	1/8"	7 deg.



STBNU125-3

Carbide-Tipped Straight Bits



SE1007

1/4" SHANK SINGLE FLUTE

Part Number	Cutting Diameter	Cutting Length	Overall Length
SE1004	1/4"	3/4"	2-1/4"
SE1005	1/4"	1"	2-1/2"
SE1007	1/4"	1"	3-1/8"

5/16" SHANK SINGLE FLUTE

Part Number	Cutting Diameter	Cutting Length	Overall Length
SE1033A	5/16"	1"	2-5/8"

3/8" SHANK SINGLE FLUTE

Part Number	Cutting Diameter	Cutting Length	Overall Length
SE1035	3/8"	1"	2-5/8"
SE1036	3/8"	1-1/4"	2-3/4"

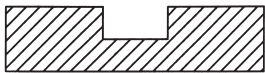

1/2" SHANK SINGLE FLUTE

Part Number	Cutting Diameter	Cutting Length	Overall Length
SE1049	3/8"	1"	2-5/8"
SE1050	3/8"	1-1/4"	2-7/8"
SE1051	1/2"	1"	2-5/8"
SE1052	1/2"	1-1/4"	3"
SE1054	1/2"	1-1/2"	3-1/4"
SE1055	1/2"	2"	4-1/8"
SE1055A	1/2"	2-1/2"	4-3/8"
SE1055C	1/2"	2-1/2"	5-1/8"



SE1052

1/4" SHANK DOUBLE FLUTE

Part Number	Cutting Diameter	Cutting Length	Overall Length	
SE1011	3/16"	1/2"	2"	
SE1012	1/4"	1/2"	2"	
SE1013	1/4"	3/4"	2-1/8"	Incra™
SE1014	1/4"	1"	2-1/2"	
SE1016	1/4"	1"	3"	
SE1016-01	1/4" (.245*)	1"	3-1/4"	*For Air Router
SE1018	9/32"	1"	2-1/2"	
SE1018A	5/16"	3/4"	2-3/4"	Leigh #140
SE1019	5/16"	1"	2-1/4"	
SE1021	3/8"	3/4"	2-1/4"	
SE1022	3/8"	1"	2-1/4"	Incra™
SE1023	3/8"	1 1/4"	2-3/4"	
NEW SE1023A	13/32"	1"	2-1/2"	
SE1024	7/16"	1"	2 1/2"	
SE1024A	31/64"	3/4"	2 1/4"	Undersize Plywood
SE1024B	15/32"	3/4"	2 1/8"	
SE1025	1/2"	1/8"	2"	
SE1025A	1/2"	1/4"	2 1/4"	
SE1025B	1/2"	1/2"	2 1/4"	
SE1025C	1/2"	3/4"	2 3/8"	
SE1026	1/2"	1"	2 3/4"	Omni Jig #43318
NEW SE1026A	1/2"	1-1/4"	2-3/4"	
SE1027	9/16"	3/4"	2 1/4"	
SE1027A	19/32"	3/4"	2 1/4"	Undersize Plywood
NEW SE1027B	5/8"	1/4"	2"	
NEW SE1027C	5/8"	1/2"	2-1/4"	
NEW SE1027D	5/8"	3/4"	2-1/2"	
SE1028	5/8"	1"	2-1/4"	
SE1029	11/16"	3/4"	2-1/8"	
SE1029A	23/32"	3/4"	2-1/8"	Undersize Plywood
SE1030	3/4"	3/4"	2-1/8"	

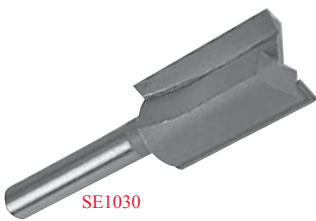
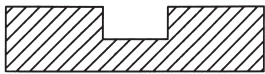

SE1030

Boring points can be added to most tools. Add (F) for Flat bottom or (V) for V-point.



Carbide-Tipped Straight Bits

Continued from
previous page

1/4" SHANK DOUBLE FLUTE

Part Number	Cutting Diameter	Cutting Length	Overall Length
SE1031	3/4"	1"	2-1/4"
SE1032	7/8"	3/4"	2-1/8"
SE1032A	13/16"	3/4"	2-1/8"
SE1033	1"	3/4"	2-1/8"
SE1303	1-1/4"	3/4"	2"

3/8" SHANK DOUBLE FLUTE

Part Number	Cutting Diameter	Cutting Length	Overall Length	
NEW SECTDS38	3/8"	9/16"	2-1/2"	CASTLE™
SE1039	3/8"	1"	2-5/8"	
SE1040	3/8"	1-1/4"	2-7/8"	
SE1041	3/8"	1-1/4"	3-5/8"	
SE1043	1/2"	1"	2-1/2"	

1/2" SHANK DOUBLE FLUTE

Part Number	Cutting Diameter	Cutting Length	Overall Length	
*SE1058	1/4"	3/4"	2-5/8"	Incra™
*SE1059	9/32"	3/4"	2-1/2"	
*SE1060	5/16"	1"	2-3/4"	
*SE1061	3/8"	3/4"	2-1/2"	
*SE1062	3/8"	1"	2-3/4"	Incra™
*SE1063	3/8"	1-1/4"	2-3/4"	
*SE1064	13/32"	3/4"	2-1/2"	
SE1065L	7/16"	1-1/4"	3-1/4"	Leigh 150
SE1065A	31/64"	1"	2-5/8"	Undersize Plywood
SE1066	1/2"	1"	2-5/8"	
SE1067	1/2"	1-1/4"	2-7/8"	Leigh 160
SE1069	1/2"	1-1/2"	3-1/8"	
SE1069DS	1/2"	1-1/2"	3-1/8"	Downshear
SE1070	1/2"	1-1/2"	4-1/4"	
SE1071	1/2"	2"	3-3/4"	
SE1072	1/2"	2"	4-1/8"	
SE1073	1/2"	2-1/2"	4-1/2"	
SE1073M	1/2"	2-1/2"	5-1/2"	
SE1074	17/32"	1-1/4"	2-7/8"	
SE1075	9/16"	1-1/4"	3"	
SE1075A	19/32"	3/4"	2-1/4"	Undersize Plywood
SE1076	5/8"	1"	2-1/2"	
SE1077	5/8"	1-1/4"	2-3/4"	
SE1078	5/8"	1-1/2"	3"	
SE1079	5/8"	2"	4"	
SE1080	21/32"	1-1/4"	3"	
SE1082	11/16"	1"	2-1/2"	
SE1083	11/16"	1-1/4"	3"	
SE1083A	23/32"	1"	2-1/2"	Undersize Plywood
SE1084	3/4"	1"	2-3/4"	
SE1085	3/4"	1-1/4"	2-3/4"	
SE1086	3/4"	1-1/2"	3"	
SE1087	3/4"	2"	3-3/4"	
SE1088	25/32"	1-1/4"	3"	
SE1090	13/16"	1-1/4"	3"	
SE1091	7/8"	1-1/4"	3"	
SE1093	1"	1-1/4"	2-3/4"	
SE1094	1"	1-1/2"	3"	
SE1095	1"	2"	3-3/4"	
SE1095A	1-1/16"	1-1/2"	3"	

*No warranty on breakage.

The above tools can be supplied with chipbreakers or boring points. Please call for prices.
For Chipbreakers add CB to part number. For boring points add (F) for Flat bottom or (V) for V-Point.

Carbide-Tipped Straight Bits

1/2" SHANK DOUBLE FLUTE

Part Number	Cutting Diameter	Cutting Length	Overall Length
NEW SE1095B	1-1/8"	1"	3"
SE1096	1-1/8"	1-1/2"	3-1/2"
SE1096A	1-1/8"	2"	4"
SE1304	1-1/4"	3/4"	2-1/8"
SE1097	1-1/4"	1-1/2"	3"
SE1098	1-3/8"	1-1/4"	3"
SE1099	1-1/2"	1-1/4"	3"
SE1100	1-3/4"	1-1/4"	3"
SE1101	2"	1-1/4"	3"



LEFT-HAND ROTATION DOUBLE FLUTE

Part Number	Cutting Diameter	Cutting Length	Shank	Overall Length
SE1014LH	1/4"	1"	1/4"	2-1/2"
NEW SE1058LH	1/4"	3/4"	1/2"	2-5/8"
NEW SE1060LH	5/16"	1"	1/2"	2-3/4"
SE1062LH	3/8"	1"	1/2"	2-3/4"
SE1066LH	1/2"	1"	1/2"	2-5/8"
SE1069LH	1/2"	1-1/2"	1/2"	3-1/8"
SE1072LH	1/2"	2"	1/2"	4-1/8"
SE1085LH	3/4"	1-1/4"	1/2"	2-3/4"
NEW SE1087LH	3/4"	2"	1/2"	3-3/4"
NEW SE1091LH	7/8"	1-1/4"	1/2"	3"



3/4" SHANK DOUBLE FLUTE (FOR CNC ROUTERS) RIGHT-HAND ROTATION

Part Number	Cutting Diameter	Cutting Length	Overall Length
SE1105	3/4"	2"	4"
SE1107	3/4"	2-1/2"	4-1/2"



3/4" SHANK DOUBLE FLUTE (FOR CNC ROUTERS) LEFT-HAND ROTATION

Part Number	Cutting Diameter	Cutting Length	Overall Length
SE1105LH	3/4"	2"	5"
SE1107LH	3/4"	2-1/2"	5-1/2"

Carbide-Tipped Staggetooth Bits

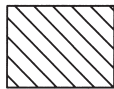
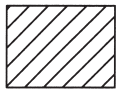

1/2" SHANK BITS (STRAIGHT FLUTE)

Part Number	Cutting Diameter	Cutting Length	Overall Length
SE1201	3/8"	1-1/2"	3-1/2"
SE1202	1/2"	1-1/2"	3-1/2"
SE1203	1/2"	2"	4-1/4"
SE1203-212	1/2"	2-1/2"	5-1/2"



OPPOSITE SHEAR BITS

Part Number	Cutting Diameter	Cutting Length	Overall Length	Shank
SE1252	1/2"	2"	4"	1/2"
SE1256	1/2"	2 -5/8"	5-1/2"	1/2"
NEW SE1261	3/4"	2"	5"	5/8"
SE1270	3/4"	2"	4"	3/4"



1

2

3

4

5

6

7

8

9

10

Carbide-Tipped Mortise Bits

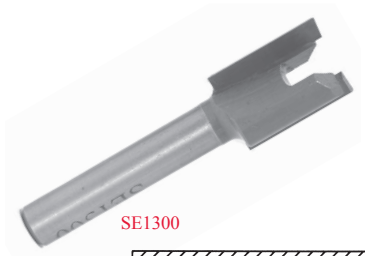

SE1300



1/4" SHANK

Part Number	Cutting Diameter	Cutting Length	Overall Length
SE1300	1/2"	5/8"	2"
SE1301	5/8"	3/4"	2"
SE1302	3/4"	3/4"	2"
SE1303	1-1/4"	3/4"	2"

1/2" SHANK

Part Number	Cutting Diameter	Cutting Length	Overall Length
SE1304	1-1/4"	3/4"	2-1/8"

Carbide-Tipped Screw-On Mortise Bits

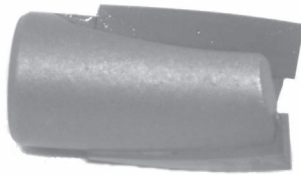

SE13500



SE131250

1/4"-28 Thread

Part Number	Cutting Diameter Fraction	Cutting Diameter Decimal	Cutting Length	Overall Length
SE13500	1/2"	.500	5/8"	7/8"
SE13515	33/64"	.515	5/8"	7/8"
SE13531	17/32"	.531	5/8"	7/8"
SE13562	9/16"	.562	5/8"	7/8"
SE13625	5/8"	.625	5/8"	7/8"
SE13640	41/64"	.640	5/8"	7/8"
SE13656	21/32"	.656	5/8"	7/8"
SE13687	11/16"	.687	5/8"	7/8"
SE13719	23/32"	.719	5/8"	7/8"
SE13750	3/4"	.750	5/8"	7/8"
SE13764	49/64"	.765	5/8"	7/8"
SE13781	25/32"	.781	5/8"	7/8"
SE13812	13/16"	.812	5/8"	7/8"
SE13875	7/8"	.875	5/8"	7/8"
SE13937	15/16"	.937	5/8"	7/8"
SE131000	1"	1.000	1/2"	1/2"
SE131125	1-1/8"	1.125	1/2"	1/2"
SE131250	1-1/4"	1.250	5/8"	5/8"
SE131375	1-3/8"	1.375	1/2"	1/2"

5/16"-24 Thread

Part Number	Cutting Diameter Fraction	Cutting Diameter Decimal	Cutting Length	Overall Length
SE131250-516	1-1/4"	1.250	5/8"	5/8"
SE131250-516A	1-1/4"	1.250	1/2"	5/8"

Arbors For Screw-On Mortise Bits

ARBORS, 1/4"-28 THREAD

Part Number	Shank Diameter	Overall Length
SEHMA-14	1/4"	1-3/4"
SEHMA-12	1/2"	1-3/4"
SEHMA-12-XL	1/2"	2 -5/8"
NEW SEHMA-12-XXL	1/2"	3-1/4"



SEHMA-12

ARBORS, 5/16"-24 THREAD

Part Number	Shank Diameter	Overall Length
SEHMA-14-516	1/4"	1-3/4"
SEHMA-12-516	1/2"	1-3/4"

Carbide-Tipped Bowl & Tray Bits

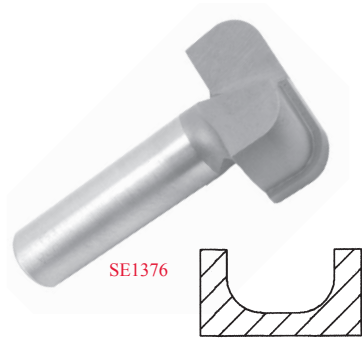

1/4" SHANK

Part Number	Cutting Diameter	Radius	Cutting Length	Overall Length
SE1370	7/16"	1/8"	5/16"	2-1/8"
SE1372	3/4"	1/4"	5/8"	2-3/8"
SE1373	1"	1/4"	1/2"	2-3/8"
* SE1372B	3/4"	1/4"	5/8"	2-3/8" <i>SBE120 bearing</i>

1/2" SHANK

Part Number	Cutting Diameter	Radius	Cutting Length	Overall Length
SE1374	3/4"	1/4"	5/8"	2-3/8"
**SE1376	1-1/4"	1/4"	1/2"	2-3/8"
*SE1376B	1-1/4"	1/4"	1/2"	2-3/8"

*Bearing supplied on shank for template routing.

**SE1376 requires SBE152 bearing.

Carbide-Tipped Core Box Bits

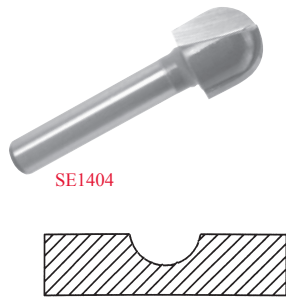

1/4" SHANK

Part Number	Cutting Diameter	Radius	Cutting Length	Overall Length
* SCR275	1/8"	1/16"	5/16"	2"
* SCR277	3/16"	3/32"	3/8"	2"
* SCR279	1/4"	1/8"	3/8"	2"
SE1402	1/4"	1/8"	1/2"	1-3/4"
SE1403	3/8"	3/16"	1/2"	1-3/4"
SE1404	1/2"	1/4"	1/2"	1-3/4"
SE1405	5/8"	5/16"	3/8"	2"
SE1406	3/4"	3/8"	5/8"	1-7/8"

*Solid Carbide

Carbide-Tipped Roundnose Bits



1/2" SHANK

Part Number	Cutting Diameter	Radius	Cutting Length	Overall Length
SE1405A	5/8"	5/16"	1/2"	2-1/4"
SE1406A	3/4"	3/8"	5/8"	2-3/8"
SE1406B	7/8"	7/16"	3/4"	2-1/2"
SE1406C	1"	1/2"	3/4"	2-1/2"
SE1407	3/8"	3/16"	1"	2-5/8"
SE1408	1/2"	1/4"	1-1/4"	2-7/8"
SE1410	5/8"	5/16"	1-1/4"	2-7/8"
SE1411	3/4"	3/8"	1-1/4"	2-3/4"
SE1412	7/8"	7/16"	1-1/4"	2-7/8"
SE1413	1"	1/2"	1-1/4"	2-3/4"
SE1414	1-1/4"	5/8"	1-1/4"	3"
SE1415	1-1/2"	3/4"	1-1/4"	3"
SE1416	1-3/4"	7/8"	1-1/4"	3"
SE1417	2"	1"	1-1/4"	3"
NEW SE1420	2-1/4"	1-3/4"	5/8"	2-1/2"

Carbide-Tipped Roundnose Template Bits

1



SE1404B

1/4" SHANK

Part Number	Cutting Diameter	Radius	Cutting Length	Overall Length
SE1404B	1/2"	1/4"	1/2"	1-3/4"
SE1406BB	3/4"	3/8"	5/8"	1-7/8"

2

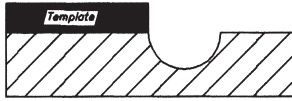

3

Carbide-Tipped Plunge-Cutting Ball Bits

4



SE1464

1/4" SHANK

Part Number	Cutting Diameter	Radius	Cutting Length	Overall Length
SE1450	3/8"	3/16"	3/8"	1-3/4"
SE1452	1/2"	1/4"	1/2"	1-3/4"

5

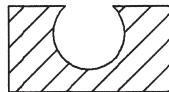

1/2" SHANK

Part Number	Cutting Diameter	Radius	Cutting Length	Overall Length
SE1460	1/2"	1/4"	1/2"	2-1/4"
SE1462	3/4"	3/8"	3/4"	2-1/2"
SE1464	1"	1/2"	1"	2-1/2"

6

Carbide-Tipped Half-Round (Bullnose)

7

1/4" SHANK

Part Number	A Opening	Radius	Cutting Length	Overall Length
SE1425	3/16"	3/32"	1/2"	1-3/4"
SE1426	1/4"	1/8"	5/8"	1-7/8"
SE1427	3/8"	3/16"	11/16"	2"
SE1428	1/2"	1/4"	7/8"	2-1/8"

8

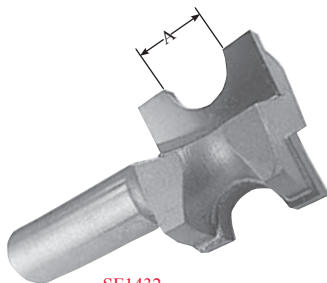

SE1432

1/2" SHANK

Part Number	A Opening	Radius	Cutting Length	Overall Length
SE1429	3/16"	3/32"	1/2"	1-7/8"
SE1430	1/4"	1/8"	5/8"	2-1/8"
SE1431	3/8"	3/16"	11/16"	2-3/16"
SE1432	1/2"	1/4"	7/8"	2-3/8"
SE1432A	5/8"	5/16"	1"	2-1/2"
SE1433	3/4"	3/8"	1-1/8"	2-5/8"
SE1434	1"	1/2"	1-3/8"	2-7/8"
SE1434A	1-1/8"	9/16"	1-1/2"	3"
SE1435	1-1/4"	5/8"	1-3/4"	3-1/4"
SE1436	1-1/2"	3/4"	1-7/8"	3-3/8"

9

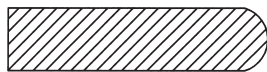

10

Carbide-Tipped Plunge Hand Grip Bits

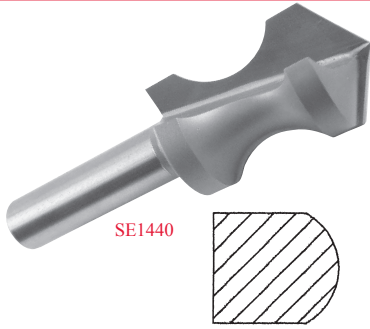

1/2" SHANK

Part Number	Cutting Diameter	Bead Opening	Cutting Depth	Cutting Length	Overall Length
SE1440	1-1/8"	7/8"	1/4"	1-5/8"	3-1/2"
SE1440B	1-1/8"	7/8"	1/4"	1-5/8"	3-1/2"

Uses SBE150 Bearing w/collar for template guide routing.

Carbide-Tipped Oval Edge (Half-Bullnose)

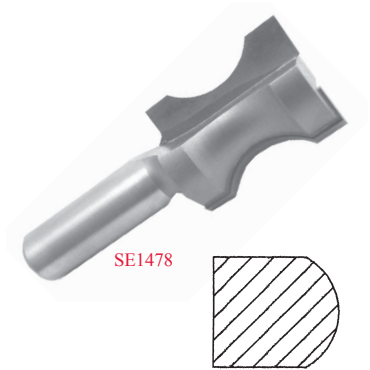

1/2" SHANK

Part Number	Bead Opening	Bead Depth	Cutting Length	Large Diameter
SE1474	1/2"	1/8"	1"	3/4"
SE1476	3/4"	3/16"	1-1/4"	1"
SE1478	1"	3/16"	1-1/4"	1"
SE1480	1 1/2"	1/4"	1-3/4"	1-1/4"

Carbide-Tipped V-Groove Bits (90° Angle)

45° PER SIDE

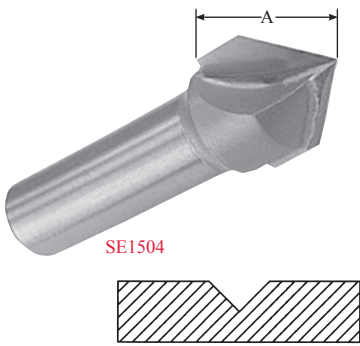

1/4" SHANK

Part Number	Cutting Diameter	A Cutting Length	Overall Length	
*SCVG260	1/4"	1/2"	1-1/2"	(1 Flute)
SE1501	3/8"	1/2"	1-3/4"	
SE1502	1/2"	1/2"	1-3/4"	
SE1502A	5/8"	5/8"	2"	
SE1502B	3/4"	5/8"	2"	

**Solid Carbide*

1/2" SHANK

Part Number	Cutting Diameter	A Cutting Length	Overall Length	Material Thickness
SE1503	1/2"	1/2"	2-1/4"	1/4"
SE1504	3/4"	5/8"	2-1/4"	3/8"
SE1505	1"	3/4"	2-3/4"	1/2"
SE1507	1-1/2"	1"	2-1/2"	3/4"
SE1508	2"	1-1/4"	2-3/4"	1"

60° PER Side - 120° Included Angle

Part Number	Cutting Diameter	Cutting Length	Overall Length	Material Thickness
NEW SE1526	1-3/4"	1/2"	2-1/4"	1/4"



Carbide-Tipped V-Groove Bits (60° Angle)

30° PER SIDE

1/4" SHANK

Part Number	Cutting Diameter	Cutting Length	Overall Length	Flutes
SE1550	1/2"	5/8"	2"	2

1/2" SHANK

Part Number	Cutting Diameter	Cutting Length	Overall Length	Flutes
SE1560	1/2"	5/8"	2-1/4"	2

60 DEGREE SOLID CARBIDE

Part Number	Cutting Diameter	Cutting Length	Overall Length	Flutes
SCVG264	1/4"	7/32"	1-1/2"	1
SE1541	1/4"	7/32"	2"	3

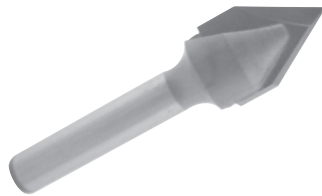

SE1550

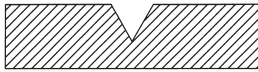

Carbide-Tipped Point Cutting Roundover

1/4" SHANK

Part Number	Radius	Cutting Diameter	Cutting Length	Overall Length
NEW SE1568	1/8"	5/16"	3/8"	2"
SE1570	3/16"	3/8"	3/8"	2"
SE1572	1/4"	1/2"	1/2"	2"
SE1574	3/8"	3/4"	5/8"	2"

1/2" SHANK

Part Number	Radius	Cutting Diameter	Cutting Length	Overall Length
SE1580	3/8"	3/4"	5/8"	2-1/4"
NEW SE1582	1/2"	3/4"	5/8"	2-1/4"
NEW SE1584	3/4"	1-1/2"	3/4"	2-1/2"

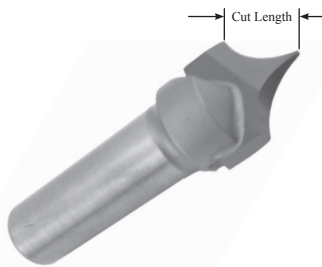

SE1580

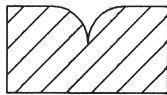

Carbide-Tipped Stair Tread & Bottom Cleaning

Part Number	Cutting Diameter	Cutting Length	Shank Diameter
SE1590	3/4"	1/2"	1/4"
SE1592	3/4"	1/2"	1/2"
SE1596	1"	1/2"	1/2"
SE1598	1-1/2"	1/2"	1/2"



SE1596

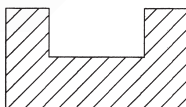

Carbide-Tipped Dovetail Bits

Part Number	Cutting Diameter	Cutting Length	Shank Diameter	Overall Length	Use
3 DEGREE ANGLE					
SE1601	7/8"	5/8"	1/2"	2 -1/2"	Stair Treads
7 DEGREE ANGLE					
SE1625	5/8"	7/8"	1/2"	2-5/8"	Incra™
SE1635	3/4"	7/8"	1/2"	2-3/4"	Incra™
SE1635LH	3/4"	7/8"	1/2"	2-3/4"	Lefthand Rotation
SE1645	7/8"	7/8"	1/2"	2-3/4"	Stair Treads
SE1645LH	7/8"	7/8"	1/2"	2-3/4"	Stair Treads
7 1/2 DEGREE ANGLE					
* SCDT7525	1/4"	5/16"	1/4"	2"	Incra™/Omni Jig
8 DEGREE ANGLE					
SE1661	5/16"	3/8"	1/4"	2-1/4"	Leigh #60
SE1662	3/8"	1/2"	1/4"	2-3/8"	Leigh #70
SE1663	7/16"	5/8"	1/4"	2-3/8"	Leigh #75
SE1664	1/2"	13/16"	1/4"	2-3/4"	Leigh #80
SE1666	11/16"	1"	1/2"	3"	Leigh #90
SE1668	13/16"	1-1/4"	1/2"	3-1/4"	Leigh #100
9 DEGREE ANGLE					
SE1605	3/8"	3/8"	1/4"	2-1/4"	Incra™
SE1613	3/8"	3/8"	3/8"	2"	
SE1615	3/8"	3/8"	1/2"	2-1/2"	
SE1615LH	3/8"	3/8"	1/2"	2-1/2"	Incra™
SE1618	.390	3/8"	1/2"	2"	
SE1618LH	.390	3/8"	1/2"	2"	
10 DEGREE ANGLE					
SE1672	1/2"	5/8"	1/4"	2-1/2"	Incra™/Leigh #101
SE1674	1/2"	5/8"	1/2"	2-5/8"	Incra™
14 DEGREE ANGLE					
SE1611	3/8"	3/8"	1/4"	2"	
SE1610	1/2"	1/2"	1/4"	2"	Incra™/Omni Jig
SE1622	1/2"	1/2"	1/4"	2-3/8"	Leigh #120
SE1620	1/2"	1/2"	1/2"	2 -1/2"	Incra™/Omni Jig
NEW SE1620LH	1/2"	1/2"	1/2"	2-1/2"	
SE1630	3/4"	3/4"	1/2"	3"	Omni Jig
SE1640	1"	7/8"	1/2"	2-1/2"	
18 DEGREE ANGLE					
SE1680	1/2"	3/8"	1/4"	2-1/4"	Leigh #128

**Solid Carbide
LH following Part No. = Lefthand.*

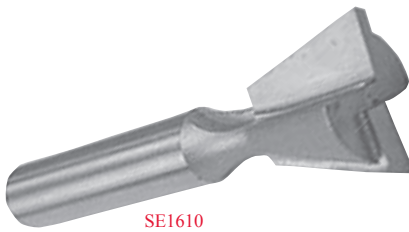

SE1610

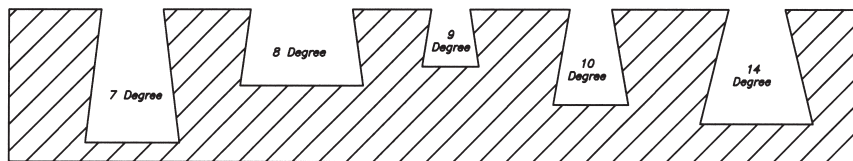

Carbide-Tipped Center Pilot Stagger Bits

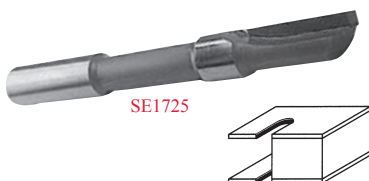

SE1725

Part Number	Cutting Diameter	Cutting Length	Shank	Overall Length
SE1725	1/2"	2-3/4"	1/2"	4-1/4"
SE1726	1/2"	2-3/4"	1/2"	4-1/4"

The SE1726 is used for CNC and very harsh applications where tool life is needed.

Carbide-Tipped Panel Pilot Bits

SINGLE FLUTE

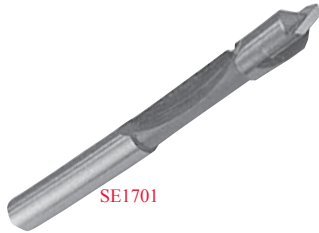

Part Number	Cutting Diameter	Cutting Length	Shank	Overall Length
SE1700	1/4"	3/4"	1/4"	2-1/2"
SE1701	3/8"	1"	3/8"	2-7/8"
SE1701-Nail	3/8"	1"	3/8"	2-7/8"
SE1702	1/2"	1-3/16"	1/2"	3-1/2"
SE1702-Nail	1/2"	1-3/16"	1/2"	3-1/2"
SE1703	1/2"	2"	1/2"	4-1/8"

SE1701-Nail and SE 1702-Nail have special carbide designed for nail and staple cutting.

DOUBLE FLUTE



Part Number	Cutting Diameter	Cutting Length	Shank	Overall Length
SE1704	3/8"	1"	1/4"	3-1/4"
SE1705	3/8"	1"	3/8"	3"
SE1706	1/2"	1-3/16"	1/2"	3-1/2"

Carbide-Tipped Cove Bits (2 Flute)



1/4" SHANK

Part Number	Radius	Cutting Diameter	Cutting Length
SE1800B	1/8"	3/4"	1/4"
SE1800A	3/16"	7/8"	1/2"
SE1800	1/4"	1"	1/2"
SE1801A	5/16"	1-1/8"	1/2"
SE1801	3/8"	1-1/4"	1/2"
SE1802	1/2"	1-1/2"	5/8"

Use SBE115 Bearing.

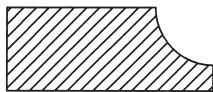

1/2" SHANK

Part Number	Radius	Cutting Diameter	Cutting Length
SE1803A	3/16"	7/8"	1/2"
SE1803	1/4"	1"	1/2"
SE1804A	5/16"	1-1/8"	1/2"
SE1804	3/8"	1-1/4"	1/2"
SE1805	1/2"	1-1/2"	5/8"
SE1806	5/8"	1-3/4"	3/4"
SE1807	3/4"	2"	1"
SE1810	1"	2-1/2"	1-1/4"

Use SBE115 Bearing.

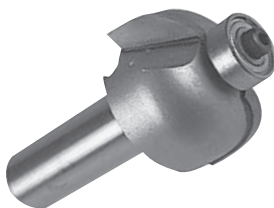

Carbide-Tipped Rabbet Bits (2 Flute)

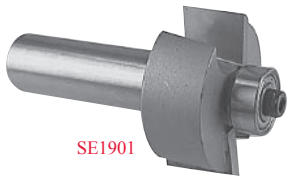

SE1901

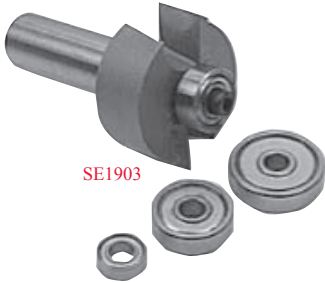

SE1903

Part Number	Cutting Diameter	Cutting Length	Cutting Depth*	Shank Diameter	Overall Length
SE1900	1-1/4"	1/2"	3/8"	1/4"	2-1/8"
SE1901	1-1/4"	1/2"	3/8"	1/2"	2-3/8"
SE1951	1-3/8"	1/2"	1/2"	1/4"	2-1/8"
SE1954	1-3/8"	1/2"	1/2"	1/2"	2-3/8"
SE1962	2"	1"	3/4"	1/2"	2-7/8"

*For different depths of cut, see kits below.

RABBETING BIT KITS

Includes SE1900 (1/4" Shank) or SE1901 (1/2" Shank) Bit and 3 additional bearings for multiple depths of 7/16", 3/8", 5/16" and 1/4".

Part Number	Description
SE1902	1/4" Shank Set
SE1903	1/2" Shank Set

Includes SE1962 Bit and 7 additional bearings for multiple depths of 13/16", 3/4", 11/16" 5/8", 19/32", 21/32", 9/16" and 1/2".

Part Number	Description
SE1965	1/2" Shank Only

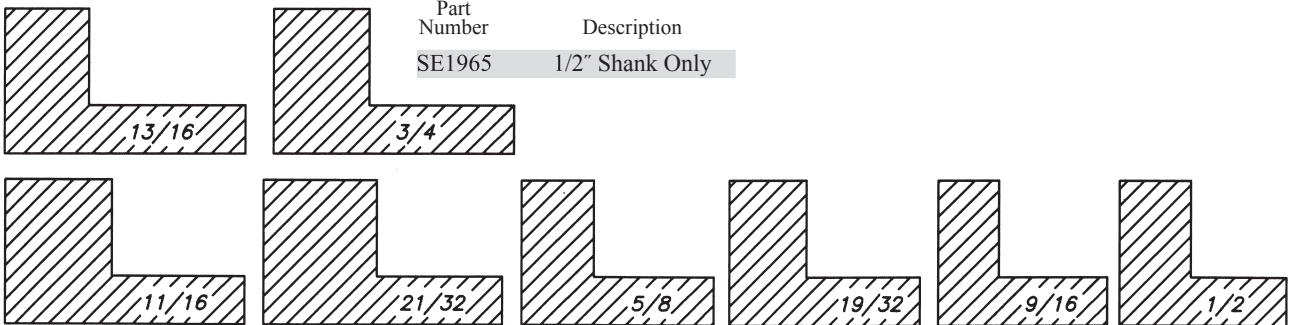

Carbide-Tipped Slotting Bits



SE1906

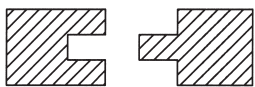

2 FLUTE

Part Number	Cutting Diameter	Cutting Length	Cutting Depth	Shank Diameter
SE1904	1-1/4"	1/8"	3/8"	1/4"
SE1908	1-1/2"	5/32"	1/2"	1/4"
SE1912	1-1/4"	1/4"	3/8"	1/4"
SE1916	1-1/4"	3/8"	3/8"	1/4"
SE1920	1-1/2"	1/2"	1/2"	1/4"

Part Number	Cutting Diameter	Cutting Length	Cutting Depth	Shank Diameter
SE1906	1-1/4"	1/8"	3/8"	1/2"
SE1910	1-1/2"	5/32"	1/2"	1/2"
SE1914	1-1/4"	1/4"	3/8"	1/2"
SE1917	1-1/4"	5/16"	3/8"	1/2"
SE1918	1-1/4"	3/8"	3/8"	1/2"
SE1922	1-1/2"	1/2"	1/2"	1/2"
SE1924	1-1/4"	3/4"	3/8"	1/2"

3 FLUTE – FOR TYLER® MACHINE

Part Number	Cutting Diameter	Cutting Length	Cutting Depth	Shank Diameter
SE1980	1-1/8"	3/16"	5/16"	3/8"

Use SBE115 Bearing.

Carbide-Tipped Roundover Bits (2 Flute)

1

2



SE2003

1/4" SHANK

Part Number	Radius	Cutting Diameter	Cutting Length
SE2000A	1/16"	5/8"	1/2"
SE2000C	1/8"	3/4"	1/2"
SE2000D	5/32"	13/16"	1/2"
SE2000	3/16"	7/8"	1/2"
SE2001	1/4"	1"	1/2"
SE2002	5/16"	1-1/8"	1/2"
SE2003	3/8"	1-1/4"	5/8"
SE2003A	7/16"	1-3/8"	11/16"
SE2004	1/2"	1-1/2"	3/4"

Use SBE115 Bearing and SDS115 Dust Shield.

3

4

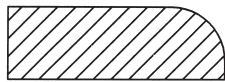

1/2" SHANK

Part Number	Radius	Cutting Diameter	Cutting Length
SE2005A	1/8"	3/4"	1/2"
SE2005	3/16"	7/8"	1/2"
SE2006	1/4"	1"	1/2"
SE2007	5/16"	1-1/8"	1/2"
SE2008	3/8"	1-1/4"	5/8"
SE2008A	7/16"	1-3/8"	11/16"
SE2009	1/2"	1-1/2"	3/4"
SE2009B	9/16"	1-5/8"	7/8"
SE2009A	5/8"	1-3/4"	1"
SE2010	3/4"	2"	1"
SE2011	7/8"	2-1/4"	1-1/8"
SE2012	1"	2-1/2"	1-5/16"
* SE2013	1-1/8"	3"	1 1/2"
* SE2014	1-1/4"	3-1/4"	1-3/4"
* SE2015	1-3/8"	3-1/2"	1-3/4"
* SE2016	1-1/2"	3-3/4"	1-7/8"

Roundovers without asterisk use SBE115 Bearing and SDS115 Dust Shield.

**Roundovers with asterisk use SBE120 Bearing and SDS120 Dust Shield.*

5

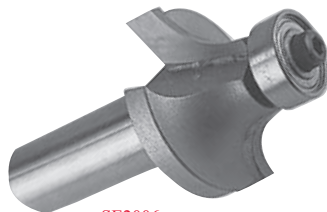

SE2006

6

7

Carbide-Tipped Plunge Roundover (2 Flute)

8

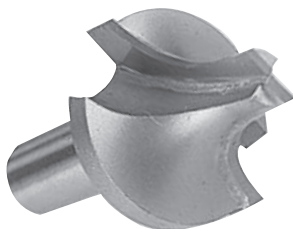

SE2060

1/4" SHANK

Part Number	Radius	Large Diameter	Small Diameter	Cutting Length
SE2050	1/8"	3/8"	1/8"	1/8"
SE2051	3/16"	5/8"	1/4"	1/8"
SE2052	1/4"	3/4"	1/4"	3/8"

1/2" SHANK

Part Number	Radius	Large Diameter	Small Diameter	Cutting Length
SE2055	1/4"	3/4"	1/4"	1/4"
SE2056	1/4"	3/4"	1/4"	3/8"
SE2057	3/8"	1"	1/4"	5/16"
SE2058	3/8"	1"	1/4"	1/2"
SE2060	1/2"	1-3/8"	3/8"	3/4"
SE2062	9/16"	1-5/8"	1/2"	1"
SE2066	3/4"	2"	1/2"	1-1/8"

9



10

Carbide-Tipped Beading Bits (2 Flute)

1/4" SHANK

Part Number	Radius	Cutting Diameter	Cutting Length
SEBE2000A	1/16"	5/8"	1/2"
SEBE2000C	1/8"	3/4"	1/2"
SEBE2000D	5/32"	13/16"	1/2"
SEBE2000	3/16"	7/8"	1/2"
SEBE2001	1/4"	1"	1/2"
SEBE2002	5/16"	1-1/8"	1/2"
SEBE2003	3/8"	1-1/4"	5/8"
SEBE2003A	7/16"	1-3/8"	11/16"
SEBE2004	1/2"	1-1/2"	3/4"

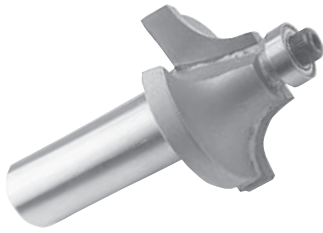

SEBE2006

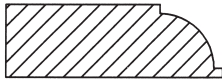

1/2" SHANK

Part Number	Radius	Cutting Diameter	Cutting Length
SEBE2005A	1/8"	3/4"	1/2"
SEBE2005	3/16"	7/8"	1/2"
SEBE2006	1/4"	1"	1/2"
SEBE2007	5/16"	1-1/8"	1/2"
SEBE2008	3/8"	1-1/4"	5/8"
SEBE2008A	7/16"	1-3/8"	11/16"
SEBE2009	1/2"	1-1/2"	3/4"
SEBE2009B	9/16"	1-5/8"	7/8"
SEBE2009A	5/8"	1-3/4"	1"
SEBE2010	3/4"	2"	1"
SEBE2011	7/8"	2-1/4"	1-1/8"
SEBE2012	1"	2-1/2"	1-5/16"
* SEBE2013	1-1/8"	3"	1-1/2"
* SEBE2014	1-1/4"	3-1/4"	1-3/4"
* SEBE2015	1-3/8"	3-1/2"	1-3/4"
* SEBE2016	1-1/2"	3-1/2"	1-7/8"

Beading Bits without asterisk use SBE110 Bearing.

**Beading Bits with asterisk use SBE130 Bearing.*

Carbide-Tipped Plunge Roundover Edge



SE2068



1/2" SHANK

Part Number	Radius	Cutting Length does not include the flat on Large Diameter		Cutting Length
		Large Diameter	Small Diameter	
SE2068	3/16"	1"	1/2"	13/16"
SE2070	3/16"	1"	1/2"	1-5/16"
SE2072	1/4"	1-1/8"	1/2"	13/16"
SE2074	1/4"	1-1/8"	1/2"	1-5/16"
SE2076	3/8"	1-3/8"	1/2"	13/16"
SE2078	3/8"	1-3/8"	1/2"	1-5/16"

Carbide-Tipped Double Roundover Bits

1/2" SHANK

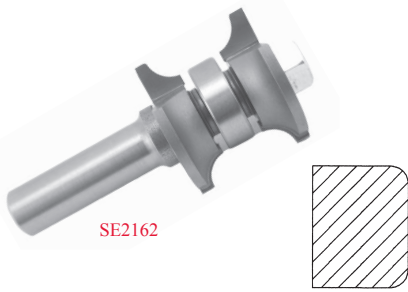

Part Number	Radius	Large Diameter	Overall Length
SE2160	1/8"	1-1/8"	3-3/4"
SE2162	3/16"	1-1/4"	3-3/4"
SE2164	1/4"	1-3/8"	3-3/4"

Replacement Parts

SE2160RH	SE2160LH	Cutters Only
SE2162RH	SE2162LH	Cutters Only
SE2164RH	SE2164LH	Cutters Only
SBE125		Bearing Only
SE21-ARBOR		Arbor Only

Carbide-Tipped Roman Ogee Bits (2 Flute)

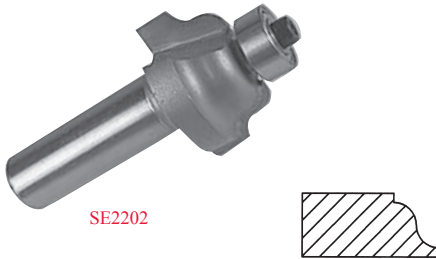

Part Number	Radius	Cutting Diameter	Cutting Length	Shank Diameter
SE2200	5/32"	1-1/8"	9/16"	1/4"
SE2201	1/4"	1-1/2"	11/16"	1/4"
SE2202	5/32"	1-1/8"	9/16"	1/2"
SE2203	1/4"	1-1/2"	11/16"	1/2"
SE2210	3/8"	2"	1"	1/2"

SBE115 Bearing

Carbide-Tipped Edge Bevel / Laminate



Part Number	Degree	Cutting Height	Cutting Length	Shank Diameter
*SE2298	7°	3/8"	3/8"	1/4"
SE2300	15°	1/2"	1/2"	1/4"
SE2300A	15°	1/4"	1/4"	1/4"
SE2300B	22°	3/8"	3/8"	1/4"
SE2301	25°	7/16"	1/2"	1/4"

*SBE110

SBE115 Bearing

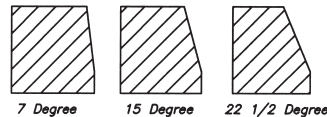

Carbide-Tipped 45° Chamfer Bits (2 Flute)



Part Number	Degree	Cutting Height	Cutting Length	Shank Diameter
SE2302	45°	7/16"	5/8"	1/4"
SE2305	45°	7/16"	5/8"	1/2"
SE2306	45°	13/16"	1-1/8"	1/2"
SE2310	45°	1-1/16"	1-1/2"	1/2"

SBE115 Bearing

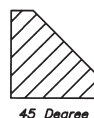

Carbide-Tipped 22¹/₂^o & 30^o Chamfer Bits



SE2307

Part Number	Degree	Cutting Height	Cutting Length	Shank Diameter
SE2307	22 1/2°	7/8"	15/16"	1/2"
SE2308A	30°	3/8"	7/16"	1/4"
SE2309	30°	7/8"	1"	1/2"
SE2315	22 1/2°	3/8"	3/8"	1/2"

SBE115 Bearing

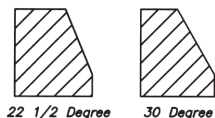

22 1/2 Degree 30 Degree

Carbide-Tipped Flush Trim Bits (2 Flute)



SE2402

1/4" SHANK

Part Number	Cutting Diameter	Cutting Length	Overall Length	Bearing
*SE2400A	1/4"	3/4"	2-1/2"	SBE100
SE2400	3/8"	1"	2-3/4"	SBE105
SE2401	3/8"	1/2"	2-1/4"	SBE105
SE2402	1/2"	1"	2-3/4"	SBE115
SE2403	1/2"	1/2"	2-3/8"	SBE115
SE2404	1/2"	1-1/2"	3-1/4"	SBE115

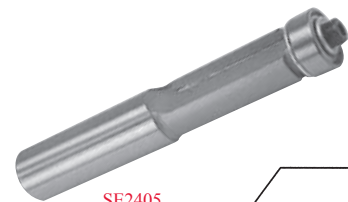

SE2405

1/2" SHANK

Part Number	Cutting Diameter	Cutting Length	Overall Length	Bearing
NEW SE2404A	3/8"	1"	3-1/8"	SBE105
SE2405	1/2"	1"	3-1/8"	SBE115
SE2406	1/2"	1/2"	2-3/4"	SBE115
SE2407	1/2"	1-1/2"	3-3/4"	SBE115
SE2408	1/2"	2"	4-1/8"	SBE115
SE2409	3/4"	1"	3-3/8"	SBE120
NEW SE2410	3/4"	1-1/4"	3-1/2"	SBE120

*SE2400A uses SE2400A-SCREW

Carbide-Tipped Flush Trim Bits (3 Flute)



SE2502

1/4" SHANK

Part Number	Cutting Diameter	Cutting Length	Overall Length	Bearing
SE2500	1/2"	1"	2-3/4"	SBE115
SE2501	1/2"	1/2"	2-3/8"	SBE115

1/2" SHANK

Part Number	Cutting Diameter	Cutting Length	Overall Length	Bearing
SE2502	1/2"	1"	3-1/8"	SBE115
SE2504	1/2"	1-1/2"	3-3/4"	SBE115
SE2505	1/2"	2"	4-1/4"	SBE115

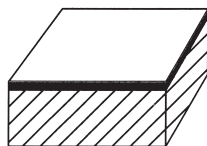

1

2

3

4

5

6

7

8

9

10

Carbide-Tipped Flush Trim Bits

1/2" Shank, Double Bearing



2 FLUTE, DOUBLE BEARING

Part Number	Cutting Diameter	Cutting Length	Overall Length	Bearing
SE2457	1/2"	1-1/2"	4"	SBE115
SE2458	1/2"	2"	4-1/2"	SBE115

3 FLUTE, DOUBLE BEARING

Part Number	Cutting Diameter	Cutting Length	Overall Length	Bearing
SE2554	1/2"	1-1/2"	4"	SBE115
SE2555	1/2"	2"	4-1/2"	SBE115

Carbide-Tipped Flush Trim V-Groove Bits

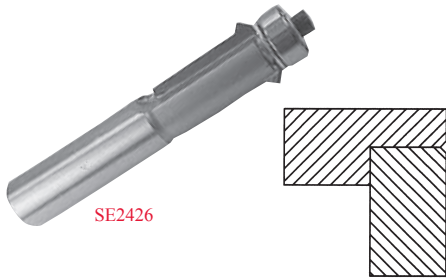

Part Number	Cutting Diameter	Cutting Length	Shank Diameter	Overall Length
SE2425	1/2"	1"	1/4"	2-3/4"
SE2426	1/2"	1"	1/2"	3-1/8"

SBE115 Bearing

Carbide-Tipped Overhang Bits

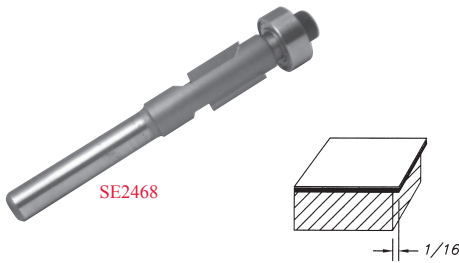

1/4" SHANK

Part Number	Overhang	Cutting Diameter	Cutting Length	Overall Length	Bearing
SE2468	1/16"	3/8"	1/2"	2-5/8"	SBE145
SE2470	1/8"	3/8"	1/2"	2-5/8"	SBE130

Carbide-Tipped Downshear Flush Trim

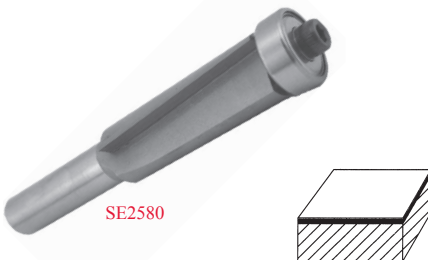

1/4" SHANK

Part Number	Cutting Diameter	Cutting Length	Overall Length
SE2562	3/8"	1"	2-5/8"
NEW SE2561	1/2"	5/8"	2-1/2"
SE2560	3/4"	5/8"	2-1/8"

1/2" SHANK

Part Number	Cutting Diameter	Cutting Length	Overall Length
SE2570	3/4"	1"	3"
SE2575	3/4"	1-1/2"	3-1/2"
SE2580	3/4"	2"	4"

Carbide-Tipped Template Bits



Part Number	Cutting Diameter	Cutting Length	Shank Diameter	Overall Length	Bearing
SE3000A	1/2"	1/8"	1/4"	2"	SBE145
SE3000	1/2"	1/4"	1/4"	2-1/4"	SBE145
SE3001	1/2"	1/2"	1/4"	2-1/4"	SBE145
SE3003	1/2"	3/4"	1/4"	2-1/4"	SBE145
SE3004	1/2"	1"	1/4"	2-3/4"	SBE145
NEW SE3005	1/2"	1-1/4"	1/4"	2-3/4"	SBE145
NEW SE3006	5/8"	1/4"	1/4"	2"	SBE130
NEW SE3007	5/8"	1/2"	1/4"	2-1/4"	SBE130
NEW SE3007A	5/8"	3/4"	1/4"	2-1/2"	SBE130
SE3008	5/8"	1"	1/4"	2-1/4"	SBE130
SE3014	3/4"	1"	1/4"	2-1/4"	SBE120
SE3018	1-1/8"	1-1/2"	1/2"	3-1/2"	SBE150
SE3019	1-1/8"	2"	1/2"	4"	SBE150
SE3020	3/4"	1"	1/2"	2-3/4"	SBE155
SE3021	3/4"	1-1/4"	1/2"	2-3/4"	SBE155
SE3022	3/4"	1-1/2"	1/2"	3"	SBE155
SE3023	3/4"	2"	1/2"	3 3/4"	SBE155

1/4" Shank Bits use SELC-1/4 Collar
 1/2" Shank Bits use SELC-1/2 Collar

Carbide-Tipped Template Bits

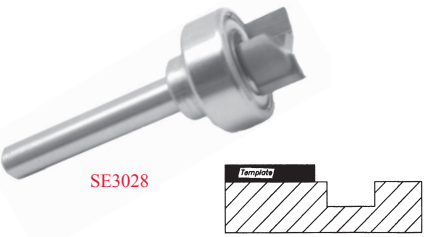

With Oversize Bearing 1/4" SHANK

Part Number	Cutting Diameter	Cutting Length	Overall Length	Bearing Diameter	Bearing
SE3025	5/16"	3/4"	2-3/4"	1/2"	SBE145
SE3028	1/2"	1/4"	2-1/4"	3/4"	SBE120
SE3032	9/16"	3/4"	2-1/4"	5/8"	SBE130

Insert Template Bits



1/2" SHANK

Part Number	Cutting Diameter	Cutting Length	Overall Length	Bearing Diameter	Insert
SEIT750-30	3/4"	30mm	3"	SBE155	SI-2951215
SEIT750-40	3/4"	40mm	3-5/16"	SBE155	SI-3951215
SEIT750-50	3/4"	50mm	3-11/16"	SBE155	SI-4951215
SEIT1125-30	1-1/8"	30mm	3"	SBE150	SI-2951215
SEIT1125-40	1-1/8"	40mm	3-5/16"	SBE150	SI-3951215
SEIT1125-50	1-1/8"	50mm	3-11/16"	SBE150	SI-4951215

Use S14-Screw
 Use SELC-1/2 Collar

Carbide-Tipped Keyhole

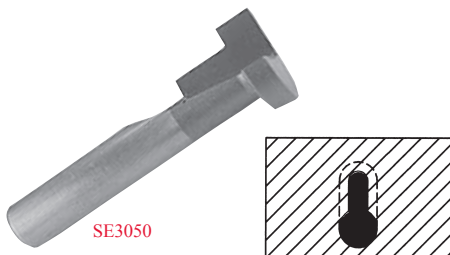

Part Number	Cutting Diameter	Small Diameter	Cutting Length	Shank Diameter	Overall Length
SE3050	3/8"	1/4"	3/8"	1/4"	1-1/2"
SE3052	1/2"	3/8"	1/2"	1/4"	1-3/4"

Carbide-Tipped T-Slot Bits

1/2" SHANK



SE3070

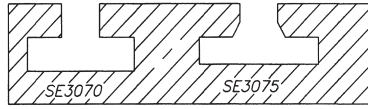

Part Number	Large Diameter	Small Diameter	Kerf Length A	Small Dia. Length B	Overall Length
SE3070	1-1/16"	3/8"	5/16"	1/2"	2-3/8"
SE3075	1-3/16"	3/8"	1/4"	3/8"	2-3/8"

Carbide-Tipped Slot & Undercut Bits

1/4" SHANK

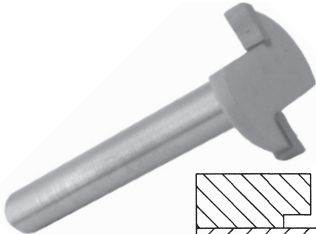

SE3094

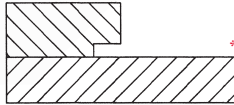

Part Number	Cutting Diameter	Kerf	Cutting Depth	Flutes	Overall Length
SE3094	3/4"	1/8"	1/4"	2	1-7/8"
SE3098	1"	1/4"	3/8"	2	2"
NEW SE3100	1-1/4"	1/4"	5/16"	2	1-3/4"
SE3110	1-1/2"	1/4"	5/8"	2	2"
** SE3114	21mm	3mm	4mm	3	1-7/8"

Add B to Part Number for Bearing on Shank

***For Laminate Flooring*

Carbide-Tipped Laminate Trim Bits with Euro™ Square Bearings

NEW!



SE2538

Part Number	Cutting Diameter	Cutting Length	Overall Length	Shank	Bearing
SE2530	1/2"	1/4"	1-5/8"	1/4"	SBE115-ES
SE2532	3/4"	5/8"	2-1/4"	1/4"	SBE140-ES
SE2538	3/4"	5/8"	2-1/4"	1/2"	SBE140-ES

Replacement Bearing • Euro™ Square

Part Number	Outside Diameter	Inside Diameter
SBE115-ES	1/2"	3/16"
SBE140-ES	3/4"	3/16"



SBE140-ES



**NEW!
IMPROVED!**

Carbide-Tipped Solid Surface Bits

Face Inlay Bits

1/2" SHANK

Part Number	Cutting Diameter	Cutting Length	Cutting Depth	Bearing
SE2906	7/8"	1/8"	1/16"	SBE120
SE2907	7/8"	1/8"	1/8"	SBE130
SE2908	7/8"	1/8"	3/16"	SBE145
SE2900	7/8"	1/4"	1/16"	SBE120
SE2901	7/8"	1/4"	1/8"	SBE130
SE2902	7/8"	1/4"	3/16"	SBE145
SE2909	7/8"	3/8"	1/16"	SBE120
SE2910	7/8"	3/8"	1/8"	SBE130
SE2911	7/8"	3/8"	3/16"	SBE145
SE2903	7/8"	1/2"	1/16"	SBE120
SE2904	7/8"	1/2"	1/8"	SBE130
SE2905	7/8"	1/2"	3/16"	SBE145
SE2912	7/8"	3/4"	1/16"	SBE120
SE2913	7/8"	3/4"	1/8"	SBE130
SE2914	7/8"	3/4"	3/16"	SBE145

SBE124 Bearing can be used for flush cutting if needed.



SE2900

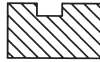

SE2926

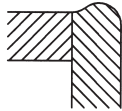

No-Drip Counter Top Bit

1/2" SHANK

Part Number	Material Thickness	Cutting Diameter	Overall Length	Bearing
SE2926	3/4"	1"	3-1/8"	SBE121

Rounding Under Bits

1/2" SHANK

Part Number	Material Thickness	Radius	Overall Length	Bearing
SE2034	1"	1/2"	2-7/8"	SBE150
SE2035	1-1/4"	5/8"	3-1/8"	SBE150
SE2036	1-1/2"	3/4"	3-1/4"	SBE150
SE2037	2"	1"	3-5/16"	SBE150



SE2036



Flush Trim Bit

1/2" SHANK

Part Number	Cutting Diameter	Cutting Length	Bearing
SE2410DS	3/4"	1"	SBE121



SE2410DS

Rounding Over Undermount Bits

1/2" SHANK

Part Number	Radius	Degree	Overall Length	Bearing
SE2930	3/4"	15°	3-1/4"	SBESS
SE2931	1/2"	18°	3"	SBESS
SE2932	9/16"	18°	3-1/4"	SBESS
SE2933	3/8"	17°	2-1/2"	SBESS
SE2934	1/2"	14°	2-1/2"	SBESS
SE2935	1/2"	17°	2-7/8"	SBESS



SE2930

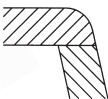

SE2945

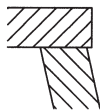

Overhang Bowl Bit

1/2" SHANK

Part Number	Material Thickness	Cutting Diameter	Overall Length	Bearing
SE2945	1/2"-3/4"	3/4"	3-3/8"	SBESS

SE2945 uses screw part number SE1032-38SP

1

2

3

4

5

6

7

8

9

10

Carbide-Tipped Solid Surface Bits

Rounding Over Bits

1/2" SHANK

Part Number	Radius	Diameter	Material Thickness	Bearing
SE2005ADS	1/8"	3/4"	1/4"	SBE117
SE2006DS	1/4"	1"	1/2"	SBE117
SE2007DS	5/16"	1-1/8"	5/8"	SBE117
SE2008DS	3/8"	1-1/4"	3/4"	SBE117
SE2009DS	1/2"	1-1/2"	1"	SBE117
SE2009ADS	5/8"	1-3/4"	1-1/4"	SBE117
SE2010DS	3/4"	2"	1-1/2"	SBE117

With Easy Ride Bearing: Part #SBE117.

Other sizes available. Select a bit from our Round Over Section, add DS after number.

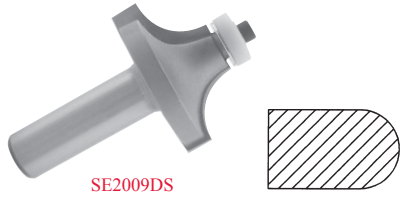

SE2009DS

Roman Ogee Undermount Bits

1/2" SHANK

Part Number	Material Thickness	Cutting Diameter	Overall Length	Bearing
SE2927	1/2"	2-1/8"	2-7/8"	SBESS
SE2928	3/4"	2-3/8"	3-1/8"	SBESS



SE2927

Bevel Undermount Bits

1/2" SHANK

Part Number	Material Thickness	Degree	Overall Length	Bearing
SE2940	1/2"-3/4"	10°	3-1/8"	SBESS
SE2942	1/2"-3/4"	12°	3-1/8"	SBESS
SE2944	1/2"-3/4"	15°	3-1/8"	SBESS

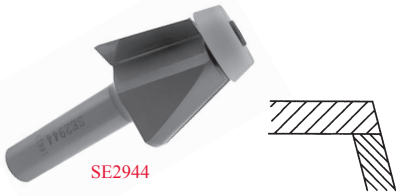

SE2944

Chamfer Bit

14° • 1/2" SHANK

Part Number	Cutting Diameter	Cutting Length	Overall Length	Bearing
SE2950	1-1/8"	1"	3-5/16"	SBE150

Collar SELC-12



SE2950

Bowl Cutter Bits

14° • 1/2" SHANK

Part Number	Cutting Diameter	Cutting Length	Overall Length	Bearing
SE2958	1-1/8"	1"	3-5/16"	SBE150

Collar SELC-12



SE2958

Bevel Bit

15° • 1/2" SHANK

Part Number	Cutting Diameter	Cutting Length	Overall Length
SE2956	1"	1-1/8"	2-3/4"



SE2956

Carbide-Tipped Solid Surface Bits



Ogee No-Drip Bits

Part Number	Cutting Diameter	Cutting Length	Shank	Overall Length
SE2952	3/4"	3/8"	1/4"	1-5/8"
SE2954	3/4"	3/8"	1/2"	2-7/8"

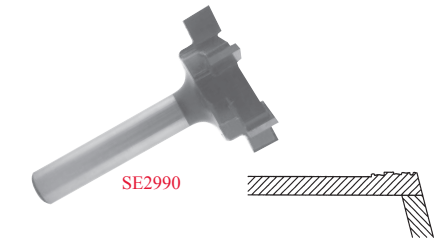

Countertop Surface Planer

1/2" SHANK (ALSO USED AS A TRIM BIT.)

Part Number	Cutting Diameter	Cutting Length	Wings
SE2986	2-1/16"	1/8"	6
SE2988	2-1/16"	1/4"	6
SE2990	2"	3/8"	6



Drainboard Bits

1/2" SHANK

Part Number	Cutting Diameter	Cutting Length	Radius	Overall Length
SE2921	1/2"	1/2"	1/8"	2"
SE2922	5/8"	1/2"	1/8"	2"
SE2923	3/4"	1/2"	1/8"	2"
SE2924	1"	1/2"	1/8"	2"



Face Cove Bit

1/2" SHANK

Part Number	Radius	Cutting Diameter	Cutting Length	Overall Length
SE2960	5/16"	1"	5/8"	2-3/4"



Backsplash Cove Bit

1/2" SHANK

Part Number	Diameter	Radius	Cutting Length	Overall Length
SE2964	1-1/8"	3/8"	1/2"	2-7/8"



Double Cove Bit

1/2" SHANK

Part Number	Diameter	Radius	Cutting Length	Overall Length
SE2968	1-1/2"	1/4"	3/4"	2-1/2"



Carbide-Tipped Solid Surface Bits

Solid Surface Problem-Solving Spiral Bits

SLOW SPIRAL 3 FLUTE RIGHT-HAND ROTATION

	Upcut Part #	Downcut Part #	Cutting Diameter	Cutting Length	Shank Diameter	Overall Length
	SRU602SL	SRD702SL	1/4"	1"	1/4"	2-1/2"
NEW	SRU611SL	N/A	3/8"	3/4"	3/8"	3"
	SRU613SL	SRD713SL	3/8"	1-1/4"	3/8"	3"
NEW	SRU621SL	N/A	1/2"	3/4"	1/2"	3"
NEW	SRU623SL	N/A	1/2"	1-1/8"	1/2"	3"
NEW	N/A	SRD724SL	1/2"	1-1/8"	1/2"	3-1/2"
	SRU625SL	SRD725SL	1/2"	1-1/4"	1/2"	3"
	SRU626SL	SRD726SL	1/2"	1-1/2"	1/2"	3-1/2"
NEW	SRU627SL	N/A	1/2"	1-1/2"	1/2"	4"
NEW	N/A	SRD728SL	1/2"	1-5/8"	1/2"	4"
NEW	SRU629SL	SRD729SL	1/2"	1-3/4"	1/2"	4"
	SRU645SL	SRD745SL	3/4"	2"	3/4"	4"
NEW	SRU648SL	N/A	3/4"	3"	3/4"	6"



SRU600SL



SE2972

1/2" Shank Bits For Wilsonart® Bowls

Part Number	Diameter	Degree	R1	R2	Cutting Length	Counter Top	Description
SE2970	1 1/2"	12°	—	—	1-1/4"	1/2"-1-1/4"	Bevel
SE2972	2 3/8"	12°	9/16"	—	7/8"	1/2"-3/4"	Roundover
SE2974	2 1/4"	13°	5/32"	13/64"	15/16"	1/2"-3/4"	Ogee

SBE149 BEARING SIWB-SCREW

Spiral Flush Trim Bits

2 FLUTE

Upcut Part #	Downcut Part #	Cutting Diameter	Cutting Length	Shank Diameter	Overall Length
SFTU120	SFTD220	1/4"	1"	1/4"	3"
SFTU155	SFTD255	1/2"	1-1/4"	1/2"	4"
SFTU165	SFTD265	1/2"	2"	1/2"	4-1/2"

Replacement Bearings 1/2" Bits **SBE145**
1/4" Bits **SBE100**

Replacement Rings 1/2" Bits **SE-E12**
1/4" Bits **SE-E25**

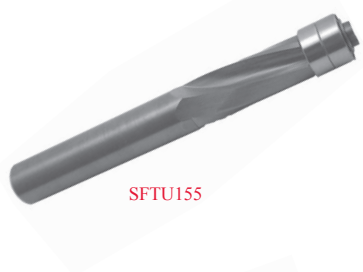

SFTU155

Spiral Flush Trim Bit

COMPRESSION, 2+2

Part Number	Cutting Diameter	Cutting Length	Shank Diameter	Overall Length
SFTUD555	1/2"	1-1/4"	1/2"	3-1/2"

Replacement Bearings 1/2" Bits **SBE145**
Replacement Rings 1/2" Bits **SE-E12**



SFTUD555



OptiCut SS

ROUTER BIT LUBE (FOR SOLID SURFACE CUTTING.)

Part Number
SE-56126

Carbide-Tipped Form Bits



SE3166



Classical Cove Bits

Part Number	Radius	Cutting Diameter	Cutting Length	Shank Diameter
SE3160	1/8"	15/16"	1/2"	1/4"
SE3162	1/4"	1"	9/16"	1/4"
SE3164	1/8"	15/16"	1/2"	1/2"
SE3166	1/4"	1"	9/16"	1/2"

SBE110 Bearing



SE3172

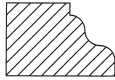

Wavy Edge Bits

Part Number	Radius	Cutting Diameter	Cutting Length	Shank Diameter
SE3170	5/32"	1-1/4"	3/4"	1/4"
SE3172	5/32"	1-1/4"	3/4"	1/2"

SBE115 Bearing



SE3180



Radius Edge Bits

Part Number	Radius	Large Diameter	Shank Diameter	Overall Length
SE3180	1/8"	7/8"	1/4"	2-5/8"
SE3182	3/16"	1"	1/4"	2-3/4"

SBE130 Bearing



SE3194



Full Bead Bits

Part Number	Radius	Cutting Diameter	Cutting Length	Shank Diameter
SE3190	1/8"	7/8"	3/8"	1/4"
SE3192	3/16"	1"	1/2"	1/4"
SE3194	1/4"	1-1/8"	5/8"	1/4"
SE3196	3/8"	1-3/8"	7/8"	1/4"

SBE130 Bearing



SE3200



Triple Bead Bits

Part Number	Radius	Cutting Diameter	Cutting Length	Shank Diameter
SE3200	1/8"	7/8"	1"	1/4"
SE3202	1/8"	7/8"	1"	1/2"

SBE130 Bearing



SE3204



Triple Flute Bits

Part Number	Radius	Cutting Diameter	Cutting Length	Shank Diameter
SE3203	1/8"	7/8"	1"	1/4"
SE3204	1/8"	7/8"	1"	1/2"

SBE130 Bearing

1

2

3

4

5

6

7

8

9

10

Carbide-Tipped Form Bits

Double Round Bits

Part Number	Radius	Cutting Diameter	Cutting Length	Shank Diameter
SE3205	5/32"	1-1/8"	1/2"	1/4"
SE3206	1/4"	1-1/2"	11/16"	1/4"
SE3207	5/32"	1-1/8"	1/2"	1/2"
SE3207A	7/32"	1-3/8"	11/16"	1/2"
SE3208	1/4"	1-1/2"	11/16"	1/2"

SBE115 Bearing

Cove & Bead Bits

Part Number	Radius	Cutting Diameter	Cutting Length	Shank Diameter
SE3209	5/32"	1-1/8"	1/2"	1/4"
SE3210	1/4"	1-5/16"	5/8"	1/4"
SE3211	5/32"	1-1/8"	1/2"	1/2"
SE3212	1/4"	1-5/16"	5/8"	1/2"
SE3282	3/8"	2"	1-3/16"	1/2"

SBE115 Bearing

Ogee Fillet Bits

Part Number	Radius	Cutting Diameter	Cutting Length	Shank Diameter
SE3214	3/16"	1-3/8"	9/16"	1/4"
SE3215	1/4"	1-5/8"	11/16"	1/4"
SE3216	3/16"	1-3/8"	9/16"	1/2"
SE3218	1/4"	1-5/8"	11/16"	1/2"

SBE115 Bearing

Ogee Bits

Part Number	Radius	Cutting Diameter	Cutting Length	Shank Diameter
SE3220	5/32"	1-1/8"	1/2"	1/4"
SE3224	1/4"	1-1/2"	11/16"	1/4"
SE3222	5/32"	1-1/8"	1/2"	1/2"
SE3226	1/4"	1-1/2"	11/16"	1/2"

SBE115 Bearing

Classical Pattern Bits

Part Number	Radius	Cutting Diameter	Cutting Length	Shank Diameter
SE3230	1/8"	1"	1/2"	1/4"
SE3234	3/16"	1-1/4"	5/8"	1/4"
SE3232	1/8"	1"	1/2"	1/2"
SE3236	3/16"	1-1/4"	5/8"	1/2"

SBE110 Bearing

Edge Beading Bits

1/4" SHANK

Part Number	Radius	Bead Diameter	Cutting Diameter	Cutting Length
SE3241	3/32"	3/16"	13/16"	1/2"
SE3244	1/8"	1/4"	7/8"	9/16"
SE3248	5/32"	5/16"	15/16"	5/8"
SE3252	3/16"	3/8"	1-1/16"	5/8"
SE3256	1/4"	1/2"	1-1/4"	3/4"

1/2" SHANK

Part Number	Radius	Bead Diameter	Cutting Diameter	Cutting Length
SE3243	3/32"	3/16"	13/16"	1/2"
SE3246	1/8"	1/4"	7/8"	9/16"
SE3250	5/32"	5/16"	15/16"	5/8"
SE3254	3/16"	3/8"	1-1/16"	5/8"
SE3258	1/4"	1/2"	1-1/4"	3/4"

SBE115 Bearing

1



SE3208

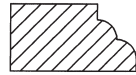

2



SE3210

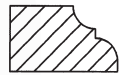

3



SE3218

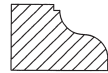

4



SE3224

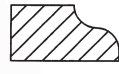

6



SE3236

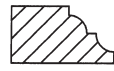

7



SE3258

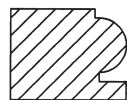

8

9

10

Carbide-Tipped Form Bits

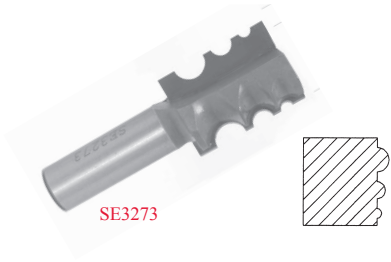

Variable Beading Bit 1/2" SHANK

Part Number	Cutting Diameter	Cutting Length	Radius 1	Radius 2	Radius 3
SE3273	7/8"	1-1/8"	5/32"	7/64"	1/16"

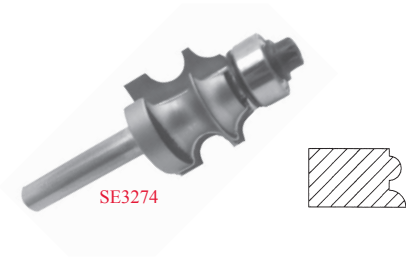

Large Bead Bits

Part Number	Radius	Cutting Diameter	Cutting Length	Shank Diameter
SE3274	5/32"	15/16"	5/8"	1/2"
SE3276	3/8"	1-1/4"	1-7/16"	1/2"

SBE115 Bearing

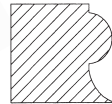
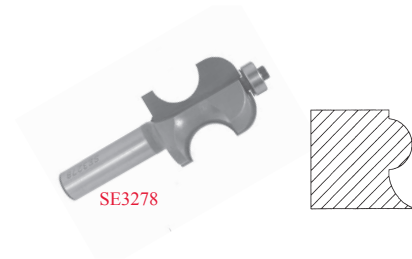

Bead & Cove Bit 1/2" SHANK

Part Number	Radius	Cutting Diameter	Cutting Length
SE3278	3/8"	1-1/4"	1-7/16"

SBE115 Bearing

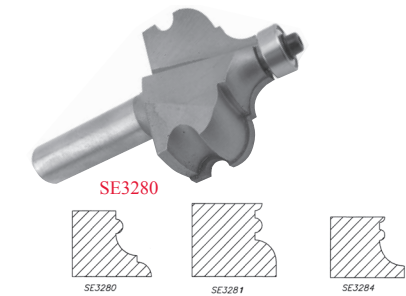

Molding Bits 1/2" SHANK

Part Number	Bead Diameter	Large Diameter	Cutting Length
SE3280	1/4"	1-3/4"	1 1/8"
SE3281	1/4"	1-1/4"	15/16"
SE3284	3/16"	1-1/4"	13/16"

SBE115 Bearing

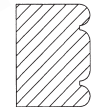

Taper Reed Bits

Part Number	Radius	Cutting Diameter	Cutting Length	Shank Diameter
SE3286	5/32"	7/8"	1"	1/4"
SE3288	5/32"	7/8"	1"	1/2"

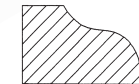
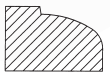
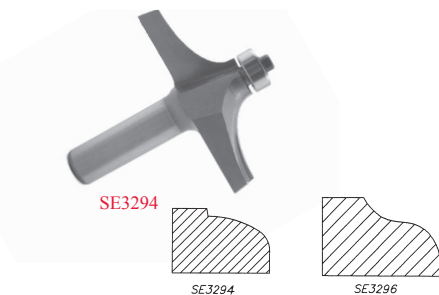

Table Edge Bits

Part Number	Depth	Diameter	Cutting Length	Shank Diameter
SE3294	1"	2-1/2"	3/4"	1/2"
SE3296	1"	2-1/2"	3/4"	1/2"

SBE115 Bearing

- 1
- 2
- 3
- 4
- 5
- 6
- 7
- 8
- 9
- 10

Carbide-Tipped Handrail Bit

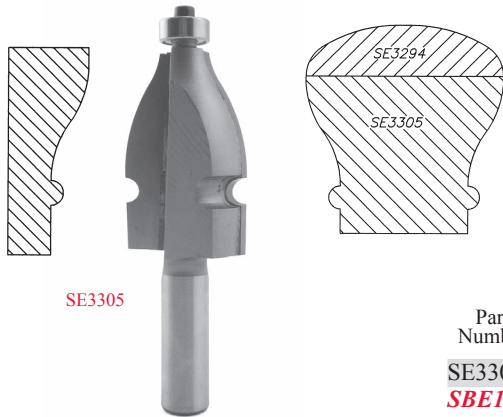

With the combination of SE3294 and SE3305 you can make this style handrail.

Have a different handrail in mind? Have Southeast Tool quote the router bits or shaper cutters, fax a drawing, or mail a wood sample to Southeast Tool.

Part Number	Bead Diameter	Cutting Diameter	Cutting Length	Shank Diameter	Overall Length
SE3305	1/4"	1-1/4"	2"	1/2"	4"

SBE115 Bearing

Carbide-Tipped Specialty Molding Bits

1/2" SHANK



Part Number	Bead Diameter	Large Diameter	Cutting Length	Overall Length
SE3320	5/16"	1"	7/8"	2-1/2"
SE3324	5/16"	15/16"	1-3/8"	3"
SE3326	1/4"	1-1/16"	1-5/8"	3-1/4"
SE3330	1/4"	1"	1-11/16"	3-5/16"

SBE115 Bearing

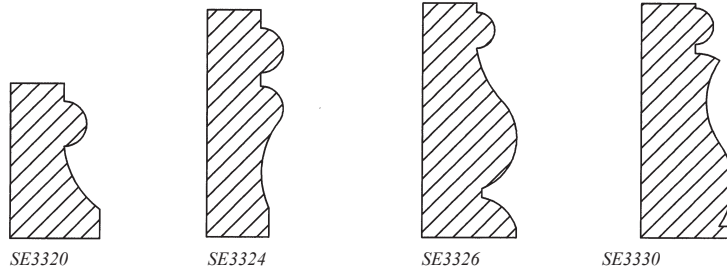

Carbide-Tipped Classical Multi-form Bit

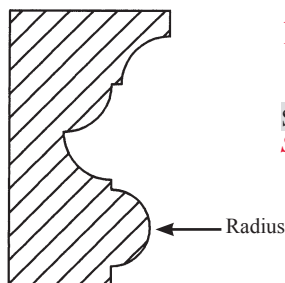

1/2" SHANK

Part Number	Radius	Large Diameter	Cutting Length
SE3342	7/32"	2-1/4"	1-7/8"

SBE115 Bearing

Carbide-Tipped Drawer Lock Bit

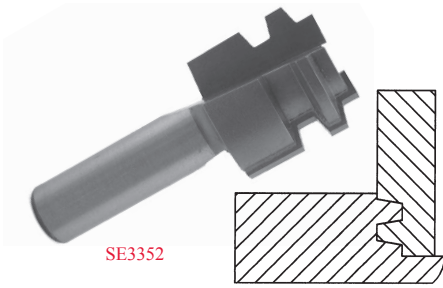

Part Number	Large Diameter	Cutting Length	Shank Diameter	Overall Length
SE3350	1-1/16"	3/4"	1/4"	2-5/16"
SE3352	1-1/16"	3/4"	1/2"	2-9/16"

Carbide-Tipped Glue Joint Bit

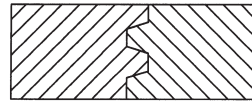

Part Number	Cutting Diameter	Cutting Length	Shank Diameter
SE3354	1-1/2"	1-1/4"	1/2"

Carbide-Tipped 45° Lock Miter

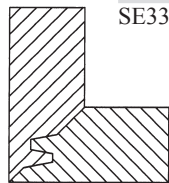

Part Number	Large Diameter	Cutting Length	Shank Diameter
SE3360	1-3/4"	3/4"	1/2"
SE3362	3-1/2"	1-5/8"	1/2"

Carbide-Tipped 22.5° Lock Miter

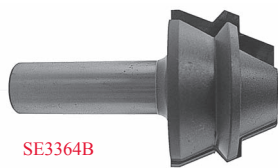

Part Number	Large Diameter	Cutting Length	Shank Diameter
NEW SE3364	1-15/32"	15/16"	1/2"

2 Piece Set

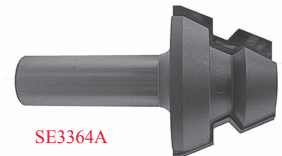

Carbide-Tipped Wedge Tongue & Groove



1/2" SHANK • 2 PIECE SET

Part Number	Material Thickness	Cutting Diameter	Cutting Length	Overall Length
SE3370	1/2" - 1-1/8"	1-1/2"	1-1/8"	2-5/8"

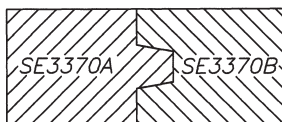

TO ORDER INDIVIDUALLY:
SE3370A - Tongue
SE3370B - Groove



NEW

Carbide-Tipped Beauty Molding Bit

1

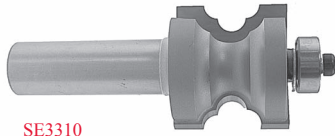

SE3310

Part Number	Cutting Diameter	Cutting Length	Shank Diameter	Radius	Overall Length
SE3310	1-1/8"	1"	1/2"	1/8"	2-15/16"

SBE115 Bearing

2

Carbide-Tipped Beaded Picture Frame Molding Bit (3-1/16" OAL)

NEW

3

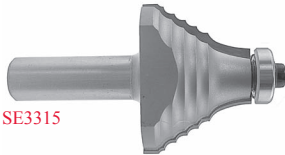

SE3315

Part Number	Cutting Diameter	Cutting Length	Shank Diameter
SE3315	3/4"	1-11/16"	1/2"

SBE130 Bearing

4

NEW

Carbide-Tipped Door Edge Profile Bits

5



SE6019



Part Number	Cutting Diameter	Cutting Length	Shank Diameter	Overall Length
SE6019	1-5/8"	3/8"	1/2"	2-5/16"
SE6020	1-5/8"	3/8"	1/2"	2-5/16"
SE6021	1-5/8"	3/8"	1/2"	2-5/16"
SE6022	1-5/8"	3/8"	1/2"	2-5/16"
SE6023	1-5/8"	3/8"	1/2"	2-5/16"

SBE115 Bearing



SE6023

6



SE6020



SE6021



SE6022

7

8

Carbide-Tipped Crown Molding Edge Trim Bit (3-3/8" OAL)

NEW

9



SE3318

Part Number	Cutting Diameter	Cutting Length	Shank Diameter	Angle 1	Angle 2
SE3318	2-3/8"	1-3/8"	1/2"	38 Deg.	52 Deg.

SBE124 Bearing

10

NEW Carbide-Tipped Ellipse Ogee Bit



Part Number	Cutting Diameter	Cutting Length	Shank Diameter	Overall Length
SE3265	1-3/4"	1/2"	1/4"	2-1/8"
SE3266	1-3/4"	1/2"	1/2"	2-1/8"

SBE115 Bearing

Carbide-Tipped Furniture/Box Maker Bit

NEW

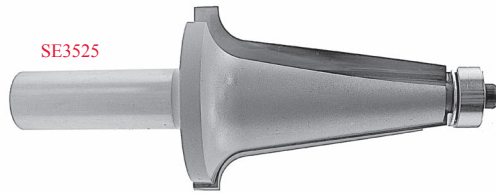

Part Number	Cutting Diameter	Cutting Length	Shank Diameter	Overall Length
SE3525	1-1/2"	1-5/8"	1/2"	3-15/16"

SBE115 Bearing

Carbide-Tipped Tongue & Groove



1/2" SHANK

Part Number	Material Thickness	Cutting Diameter	Tongue Width	Bearing
SE3375	1/2" to 13/16"	1-5/8"	9/32"	SBE125

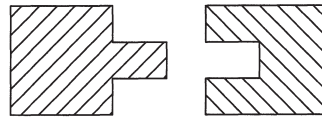

Replacement Parts:

- SE3375G - Slotting Cutter
- SAR500-1716 - Arbor
- SBE125 - Bearing
- SESK-012 - Shim Kit

Carbide-Tipped Finger Joint Assembly

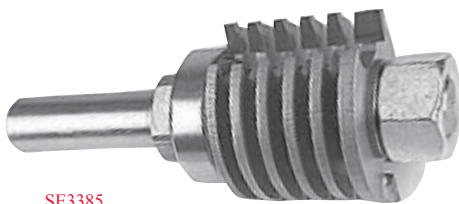

Part Number	Cutting Diameter	Cutting Length	Finger Depth	Shank Diameter
SE3385	1 9/16"	1-1/4"	7/32"	1/2"

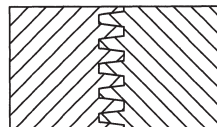

1

2

3

4

5

6

7

8

9

10

Carbide-Tipped Plunge Ogee Bits

1

2

3

4

5

6

7

8

9

10

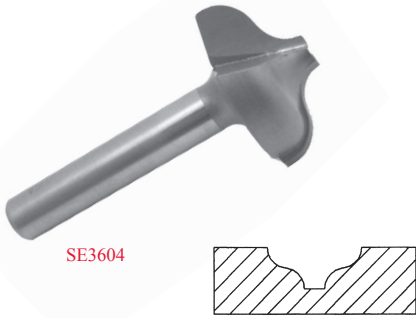

1/4" SHANK

Part Number	Radius	Cutting Diameter	Cutting Length	Shank Diameter
SE3601	1/16"	3/8"	3/8"	1/4"
SE3602	3/32"	1/2"	3/8"	1/4"
SE3603	1/8"	3/4"	7/16"	1/4"
SE3604	3/16"	7/8"	1/2"	1/4"

1/2" SHANK

Part Number	Radius	Cutting Diameter	Cutting Length	Shank Diameter
SE3605	1/16"	3/8"	3/8"	1/2"
SE3605A	3/32"	1/2"	3/8"	1/2"
SE3605B	1/8"	3/4"	7/16"	1/2"
SE3606	3/16"	7/8"	5/8"	1/2"
SE3608	3/16"	1-1/4"	11/16"	1/2"

Carbide-Tipped Classical Round Bottom

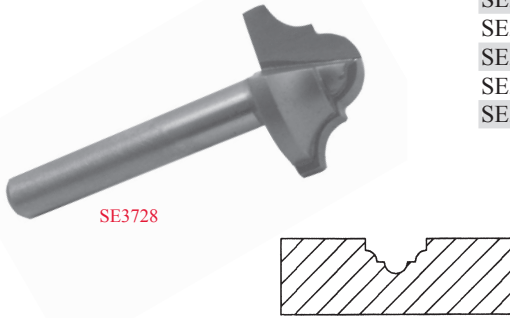

Part Number	Radius	Large Diameter	Cutting Length	Shank Diameter
SE3719	3/32"	1/2"	3/8"	1/4"
SE3728	5/32"	3/4"	1/2"	1/4"
SE3733	5/32"	3/4"	1/2"	1/2"
SE3738	7/32"	1"	5/8"	1/2"
SE3752	3/8"	1-1/2"	3/4"	1/2"

Carbide-Tipped MDF Door Bits

TOOLS CAN BE MADE IN INSERT AND PCDD
DIAMOND TIPPED CALL FOR PRICING

1/2" SHANK – STILE PROFILE

Part Number	Large Diameter	Style	Overall Length
SE5610	7/8"	Bead	2-1/2"
SE5620	1-1/4"	Traditional	2-1/2"

1/2" SHANK – PANEL PROFILE

Part Number	Large Diameter	Style	Overall Length
SE5710	1-1/2"	Cove	2-1/2"
SE5720	1-1/2"	Straight	2-1/2"
SE5725	1-1/2"	Ogee	2-1/2"

SE5620



SE5720



SE5610



SE5620



SE5710



SE5720



SE5725

Carbide-Tipped Vertical Panel Bits



1/2" SHANK

Part Number	Cutting Diameter	Cutting Length	Style
SE5801	1"	1-1/2"	Cove
SE5802	1"	1-1/2"	Straight
SE5804	1"	1-1/2"	Ogee
SE5805	1"	1-1/2"	Ogee Bead



SE5801

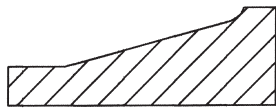

SE5802



SE5804



SE5805

Carbide-Tipped Raised Panel Bits



SE5900H

2 WING

Part Number	Cutting Diameter	Cutting Depth	Shank Diameter	Bearing
SE5900B	3-1/4"	1-3/8"	1/2"	SBE115
SE5900E	3-1/4"	1-3/8"	1/2"	SBE115
SE5900H	3-1/4"	1-3/8"	1/2"	SBE115



15°

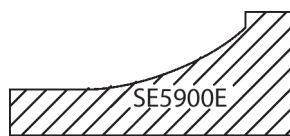

Cove



Ogee

Carbide-Tipped Raised Panel Bits



SE5950

1/2" SHANK • 2 WING • 2 1/2" DIAMETER

Part Number	Cutting Depth	Bearing	Profile
SE5950	1"	SBE115	Cove
SE5951	1"	SBE115	Ogee
SE5952	1"	SBE115	Straight

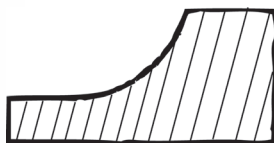

Cove



Ogee

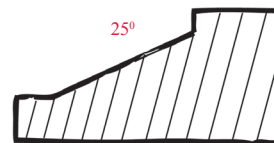

25°
Straight



Carbide-Tipped Stile & Rail Bits

1/2" SHANK • 2-PIECE SET

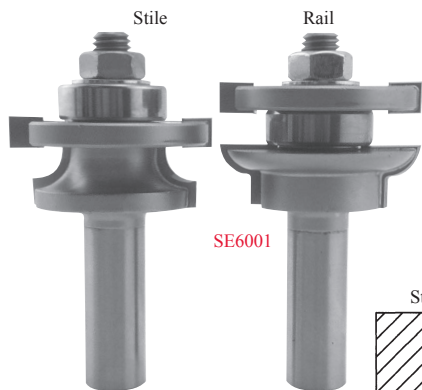

Part Number	Cutting Diameter	Cutting Depth	Pattern
SE6001	1-5/8"	1"	Round
SE6002	1-5/8"	1"	Ogee
SE6003	1-5/8"	1"	Bead

Bearing SBE125
Shim Kit SESK-012
Groover SE6000G

SE6001

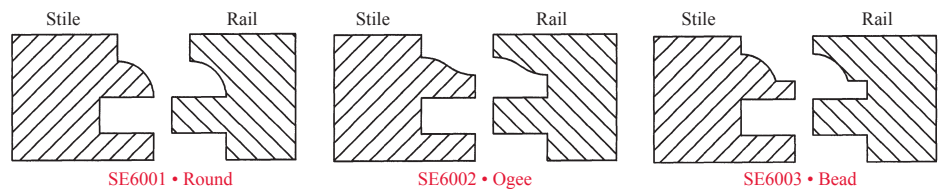

SE6001 • Round

SE6002 • Ogee

SE6003 • Bead

Carbide-Tipped Bits

Double Stile & Rail Bit

1/2" SHANK

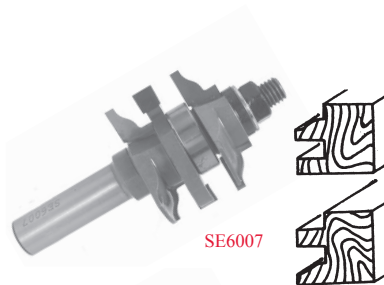

SE6007

Part Number	Cutting Diameter	Cutting Depth	Pattern
SE6007	1-5/8"	3/8"	Ogee

Bearing SBE125
Shim Kit SESK-012

Recessed Door Edge Bit



SE6010

Part Number	Cutting Diameter	Cutting Length	Shank
SE6010	1-1/2"	1-3/16"	1/2"

European Door Edge Bit



SE6016

Part Number	Large Diameter	Small Diameter	Shank Diameter	Overall Length
SE6016	1-3/4"	5/8"	1/2"	2-3/8"

Drawer Pull Bits



SE6024

Part Number	Radius	Cutting Diameter	Cutting Length	Shank Diameter
SE6024	3/16"	3/4"	7/8"	1/2"
SE6026	1/4"	1-1/2"	7/8"	1/2"

Carbide-Tipped Window Sill Edge Bits

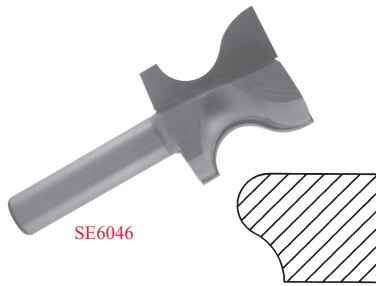

THESE BITS CAN ALSO BE USED FOR DRAWER PULLS

Part Number	Radius	Cutting Diameter	Cutting Length	Shank Diameter
SE6045	7/32"	1-1/4"	13/16"	1/2"
SE6046	3/8"	1-7/16"	1-1/8"	1/2"

SE6046

Carbide-Tipped Window Sash Bit

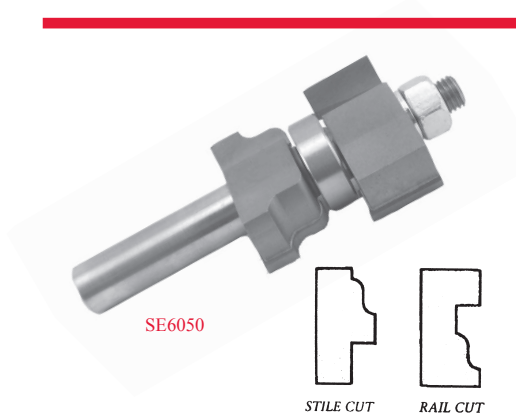

1/2" SHANK

Part Number	Cutting Diameter	Cutting Length	Overall Length
SE6050	1-3/8"	7/8"-1-5/8"	3-5/8"

REPLACEMENT PARTS

- Arbor *SAR500WS*
- Bearing *SBE125*
- Profile Cutter *SE6050P*
- Spacer *SE6050SP*
- Straight Cutter *SE6050C*
- Shim Kit: *SESK-012*

SE6050

STILE CUT RAIL CUT

Carbide-Tipped Plywood Bit, 2 Flute

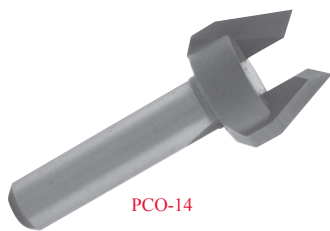

Part Number	Cutting Diameter	Cutting Length	Shank Diameter
PCO-14	5/16" - 9/16"	5/16"	1/4"

PCO-14

This bit is used to cut out imperfections in plywood, for resurfacing

Polished Solid Carbide Knives



SKN7506

Part Number	Description
SKN6254	1/8" x 5/8" x 4"
SKN6256	1/8" x 5/8" x 6"
SKN6258	1/8" x 5/8" x 8"
SKN7504	1/8" x 3/4" x 4"
SKN7506	1/8" x 3/4" x 6"
SKN7508	1/8" x 3/4" x 8"

*All knives sold individually.
Special sizes available, call for a quote.*

1

2

3

4

5

6

7

8

9

10

Carbide-Tipped Slotting Cutters

1

2 Wing • Cutters Only 1 7/8" DIAMETER X 5/16" BORE

Part Number	Decimal	Kerf Fractional
SL062-2	.062"	1/16"
SL078-2	.078"	5/64"
SL093-2	.093"	3/32"
SL125-2	.125"	1/8"
SL157-2	.156"	5/32"
SL187-2	.187"	3/16"
SL250-2	.250"	1/4"

Special sizes available, call for a quote.

1-5/8" Diameter

SE3375G .281 9/32"
For Tongue & Groove Assembly

SE6000G .250 1/4"
For Stile & Rail Assembly



2 Wing • Assembly

1/4" SHANK Part Number	1/2" SHANK Part Number
SL062-2A2	SL062-2A5
SL078-2A2	SL078-2A5
SL093-2A2	SL093-2A5
SL125-2A2	SL125-2A5
SL157-2A2	SL157-2A5
SL187-2A2	SL187-2A5
SL250-2A2	SL250-2A5

Assembly comes complete with arbor & bearing SBE125

2

3

3 Wing • Cutters Only 1 7/8" DIAMETER X 5/16" BORE

Part Number	Decimal	Kerf Fractional
SL050-3	.050"	n/a
SL055-3	.055"	n/a
SL062-3	.062"	1/16"
SL070-3	.070"	n/a
NEW SL078-3	.078"	5/64"
SL080-3	.080"	n/a
SL093-3	.093"	3/32"
SL100-3	.100"	n/a
SL106-3	.106"	n/a
SL110-3	.110"	7/64"
SL115-3	.115"	n/a
SL125-3	.125"	1/8"
SL140-3	.140"	9/64"
SL157-3	.156"	5/32"
SL187-3	.187"	3/16"
SL218-3	.218"	7/32"
SL250-3	.250"	1/4"
SL281-3	.281"	9/32"



3 Wing • Assembly

1/4" SHANK Part Number	1/2" SHANK Part Number
SL050-3A2	SL050-3A5
SL055-3A2	SL055-3A5
SL062-3A2	SL062-3A5
NEW SL070-3A2	SL070-3A5
SL078-3A2	SL078-3A5
SL080-3A2	SL080-3A5
SL093-3A2	SL093-3A5
SL100-3A2	SL100-3A5
SL106-3A2	SL106-3A5
SL110-3A2	SL110-3A5
SL115-3A2	SL115-3A5
SL125-3A2	SL125-3A5
SL140-3A2	SL140-3A5
SL157-3A2	SL157-3A5
SL187-3A2	SL187-3A5
SL218-3A2	SL218-3A5
SL250-3A2	SL250-3A5
SL281-3A2	SL281-3A5

Assembly comes complete with arbor & bearing SBE125.

Special sizes available, call for a quote.

4

5

6

7

8

4 Wing • Cutters Only 1 7/8" DIAMETER X 5/16" BORE

Part Number	Decimal	Kerf Fractional
SL062-4	.062"	1/16"
SL070-4	.070"	n/a
SL080-4	.080"	n/a
SL093-4	.093"	3/32"
SL125-4	.125"	1/8"
SL157-4	.156"	5/32"
SL187-4	.187"	3/16"
SL250-4	.250"	1/4"
SL281-4	.281"	9/32"



4 Wing • Assembly

1/4" SHANK Part Number	1/2" SHANK Part Number
SL062-4A2	SL062-4A5
SL070-4A2	SL070-4A5
SL080-4A2	SL080-4A5
SL093-4A2	SL093-4A5
SL125-4A2	SL125-4A5
SL157-4A2	SL157-4A5
SL187-4A2	SL187-4A5
SL250-4A2	SL250-4A5
SL281-4A2	SL281-4A5

Assembly comes complete with arbor & bearing SBE125.

9

10

See next page for arbors.

Carbide-Tipped Slotting Cutters

3 Wing • Cutters Only

1 7/8" DIAMETER X 5/16" BORE
COUNTERSINK

Part Number	Decimal	Kerf	Fractional
FBL062-3	.062		1/16"
FBL093-3	.093		3/32"
FBL125-3	.125		1/8"
FBL157-3	.157		5/32"
FBL187-3	.187		3/16"
FBL250-3	.250		1/4"

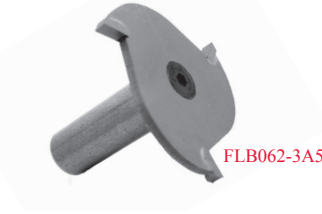

3 Wing • Assembly

1/4" SHANK 1/2" SHANK
Part Number Part Number

FBL062-3A2	FBL062-3A5
FBL093-3A2	FBL093-3A5
FBL125-3A2	FBL125-3A5
FBL157-3A2	FBL157-3A5
FBL187-3A2	FBL187-3A5
FBL250-3A2	FBL250-3A5

Arbors For Slotting Cutters SAR250

Part Number	Shank Diameter	Arbor Diameter	Arbor Length	Overall Length
SAR250	1/4"	5/16"	7/8"	2-3/8"
SAR375	3/8"	5/16"	7/8"	2-5/8"
SAR500	1/2"	5/16"	7/8"	2-3/8"
SAR500-1716	1/2"	5/16"	1 7/16"	3-1/16" (T&G Assembly)

Add A to the end of part number for arbor with bearing SBE125 (SAR250A).



Arbors For FBL Series

Part Number	Shank	Overall Length
SARF250	1/4"	1-1/2"
NEW SARF250-XL3	1/4"	3"
SARF500	1/2"	1-1/2"
SARF500-XL3	1/2"	3"

SARF1032-516

SCREWS FOR ARBORS
SARF1032-12
SARF1032-38

4 Wing & 6 Wing

Drawer Slot Cutters

1 1/4" DIAMETER X 3/8"-24 THREAD
FOR JEMCO® MACHINE

Part Number	Wings	Decimal	Kerf	Fractional
SJM187-4	4	.187"		3/16"
SJM250-4	4	.250"		1/4"
SJM187-6	6	.187"		3/16"
SJM250-6	6	.250"		1/4"
SJM281-6	6	.281"		9/32"

Special sizes available, call for a quote.



4 Wing & 6 Wing

Drawer Slot Cutters

1 1/4" DIAMETER X 5/16" BORE

Part Number	Wings	Decimal	Kerf	Fractional
SDR187-4	4	.187"		3/16"
SDR250-4	4	.250"		1/4"
SDR187-6	6	.187"		3/16"
SDR250-6	6	.250"		1/4"

Special sizes available, call for a quote.

2 Wing Cutters

For TOPMASTER® Machine

2 1/2" DIAMETER X 3/8" BORE

Part Number	Decimal	Fractional
STOP060	.060"	n/a
STOP062	.062"	1/16"
STOP070	.070"	n/a
STOP080	.080"	n/a
STOP085	.085"	n/a
STOP090	.090"	n/a
STOP093	.093"	3/32"
STOP095	.095"	n/a
STOP100	.100"	n/a
NEW STOP105	.105"	n/a
STOP110	.110"	7/64"
STOP115	.115"	n/a
STOP125	.125"	1/8"
STOP130	.130"	n/a
STOP140	.140"	9/64"
STOP150	.150"	n/a
STOP160	.160"	n/a
STOP170	.170"	11/64"
STOP180	.180"	n/a

Special sizes available, call for a quote.

Arbors For JEMCO®

Slot Cutters

3/8"-24 THREAD

Part Number	Shank	Overall Length
SARJM250	1/4"	2"
SARJM375	3/8"	2"
SARJM500	1/2"	2"

3 Wing Cutters NEW

For TOPMASTER® Machine

2 1/2" DIAMETER X 3/8" BORE

Part Number	Decimal	Fractional
STOP093-3	.093"	3/32"
STOP115-3	.115"	n/a
STOP125-3	.125"	1/8"

Special sizes available, call for a quote.

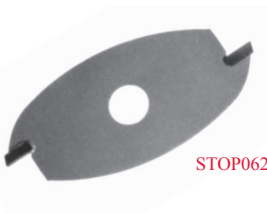

Adjustable Slotting Cutter Assembly

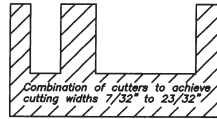
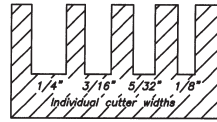
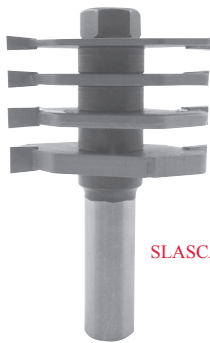

Part Number	Cutting Diameter	Cutting Length	Shank
SLASCA	1-7/8"	1/8"-23/32"	1/2"

To make various width cuts by combining slotters to achieve desired width.

Replacement Parts

SL125-2	1/8" 2 Wing Slotter
SL157-2	5/32" 2 Wing Slotter
SL187-2	3/16" 2 Wing Slotter
SL250-2	1/4" 2 Wing Slotter
SAR500-1716	Arbor
SBE125	Bearing
SESK-012	Shim Kit

Steel Router Collets

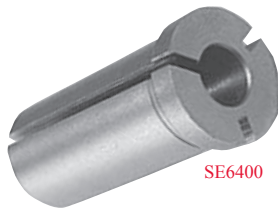

Part Number	I.D.	O.D.	Overall Length
SE6390	1/8"	1/2"	1-1/4"
SE6395	3/16"	1/2"	1-1/4"
SE6400	1/4"	1/2"	1-1/4"
SE6401	5/16"	1/2"	1-1/4"
SE6402	3/8"	1/2"	1-1/4"
SE6403	10mm	1/2"	1-1/4"

Other sizes available, call for quote.

Solid Brass Inlay Kit



Part Number	Description
SE9500	Inlay Kit W/ 1/8" Downcut Spiral SRD203

Will work on any router that will accept a 1 3/8" diameter bushing. (Porter-Cable® and Black & Decker®)

Template Guide Kit



SE9700 Kit Includes:

Part Number	Description	Barrel Length	Usage
SE976575	21/32" I.D. x 3/4" O.D.	3/16"	Lock Face Routing
SE973443	11/32" I.D. x 7/16" O.D.	3/16"	Dovetailing 1/2"
SE974050	13/32" I.D. x 1/2" O.D.	3/16"	General
SE972837	9/32" I.D. x 3/8" O.D.	3/16"	General
SE976279	5/8" I.D. x 51/64" O.D.	3/16"	Hinge
SE975362	17/32" I.D. x 5/8" O.D.	3/16"	Stanley Template
SE972531	1/4" I.D. x 5/16" O.D.	3/16"	Dovetailing 1/4"
SE971125N	Locking Nut		

Guides and Nut can be ordered separately

Accessories

BALL BEARINGS

Part Number	Outside Diameter	Inside Diameter
SBE100	1/4"	1/8"
SBE188	.365"	1/8" (For sharpened tools)
SBE105	3/8"	1/8"
SBE106	3/8"	1/4"
SBE110	3/8"	3/16"
SBE190	.490"	3/16" (For sharpened tools)
SBE193	.490"	1/4" (For sharpened tools)
SBE107	1/2"	1/8"
SBE145	1/2"	1/4"
SBE115	1/2"	3/16"
SBE117	1/2"	3/16" (Delrin Sleeve Bearing)
SBE119	3/4"	6mm
SBE135	5/8"	3/16"
SBE130	5/8"	1/4"
SBE138	11/16"	3/16"
SBE160	11/16"	1/4"
SBE195	.740"	3/16" (For sharpened tools)
SBE197	.740"	1/4" (For sharpened tools)
SBE140	3/4"	3/16"
SBE120	3/4"	1/4"
SBE121	3/4"	1/4" (Delrin Sleeve Bearing)
SBE155	3/4"	1/2"
SBE122	13/16"	3/16"
SBE123	7/8"	3/16"
SBE124	7/8"	1/4"
SBE125	7/8"	5/16"
SBE127	7/8"	3/8"
NEW SBE128	22mm	8mm
SBE147	1"	3/16"
NEW SBE149	1"	1/4"
SBE150	1 1/8"	1/2"
SBE152	1 1/4"	1/2"
SBE153	1 3/8"	1/2"
NEW SBE154	1-1/2"	1/2"
*SBESS	3/4"	1/4"

*Used on Solid Surface Bits requiring angle bearing

EURO™

Part Number	Outside Diameter	Inside Diameter
SBE115-ES	1/2"	3/16"
SBE140-ES	3/4"	3/16"



SELC-14



SBE125



SBE140-



SDS115

DUST SHIELDS

To Reduce the Effect of Dust and Glues on Bearings

Part Number	Outside Diameter	Inside Diameter	Description
SDS105	3/8"	1/8"	For SBE105
SDS115	1/2"	3/16"	For SBE115
SDS120	3/4"	1/4"	For SBE120

Packaged 10 pieces per pack

RETAINING RINGS

Part Number	Tool Diameter	Package
SE-E12	1/2"	10 pc
SE-E25	1/4"	10 pc

BEARING LOCK COLLARS

Part Number	Inside Diameter	Outside Diameter
SELC-18	1/8"	15/64"
SELC-14	1/4"	7/16"
SELC-12	1/2"	11/16"
SELC-Screw	10 pieces per pack	
SEHK-116	Hex Key Wrench	

BALL BEARINGS

(For sharpened tools)

Part Number	Outside Diameter	Inside Diameter
SBE188	.365"	1/8"
SBE190	.490"	3/16"
SBE193	.490"	1/4"
SBE195	.740"	3/16"
SBE197	.740"	1/4"

BEARING KITS

Part Number	Description
SBE200	BEARING KIT • 5 PIECE 3/8", 1/2", 5/8", 3/4" All with 3/16" ID 1 Hex Key Wrench
SBK022	SHARPENER'S BEARING KIT 22 PIECE 5 PC. SBE115 3 PC. SBE110 1 PC. SBE120 1 PC. SBE155 1 PC. SBE190 1 PC. SBE193 1 PC. SBE195 1 PC. SBE197 1 PC. SELC-14 5 PCS. SE540-14 1 PC. SELC-12 1 PC. SEHK-332

SOCKET HEAD CAP SCREWS

Part Number	Thread Size	Thread Length
SE348-14	3-48	1/4"
SE540-14	5-40	1/4"
SE540-38	5-40	3/8"
SE1032-38	10-32	3/8"

Packaged 10 pieces per pack

SHIM/SPACER KIT • 12 PIECE

For any assembly using 5/16" arbor that may need adjustment. All spacers are 5/16" ID x 5/8" O.D. Kit includes 3 each of the following thicknesses: 6mm, 1mm, .5mm, and .1mm.

Part Number — SESK-012

HEX KEY WRENCHES

Part Number	Size	Application
SEHK-116	1/16"	Bearing Lock Collars
SEHK-564	5/64"	1/8" ID Bearings (3-48) Screw
SEHK-332	3/32"	3/16" ID Bearings (5-40) Screw
SEHK-532	5/32"	1/4" ID Bearings (10-32) Screw

1

2

3

4

5

6

7

8

9

10

Carbon Steel Router Blanks For Carbide Tipping

All 1/2" Shank and 3" OAL

1/8" Under Size



Part Number	Diameter	Cutting Length
SECSRB-34	3/4"	1-1/2"
SECSRB-1	1"	1-1/2"
SECSRB-114	1-1/4"	1-1/2"
SECSRB-112	1-1/2"	1-1/2"
SECSRB-134	1-3/4"	1-1/2"
SECSRB-2	2"	1-1/2"
SECSRB-214	2-1/4"	1-1/2"
SECSRB-212	2-1/2"	1-1/2"

High-Speed Steel Router Blanks Finished Ground

All 1/2" Shank and 3" OAL



Part Number	Diameter	Cutting Length
SEHSSRB-34	3/4"	1-1/2"
SEHSSRB-1	1"	1-1/2"
SEHSSRB-114	1-1/4"	1-1/2"
SEHSSRB-112	1-1/2"	1-1/2"
SEHSSRB-134	1-3/4"	1-1/2"
SEHSSRB-2	2"	1-1/2"
SEHSSRB-214	2-1/4"	1-1/2"
SEHSSRB-212	2-1/2"	1-1/2"
SEHSSRB-234	2-3/4"	1-1/2"
SEHSSRB-3	3"	1-1/2"

Hollow Mortising Chisels • USA



Part Number	Diameter	Cutting Diameter	Mortising Depth	Overall Length
SEHMC750	3/4"	1-1/8"	3"	5-1/2"
SECB-34	3/4"	1/2"	3"Cut Depth	9"
SECB-34HS	3/4"	1/2"	3"Cut Depth	9"
SECB-34CT	3/4"	1/2"	3"Cut Depth	9"

Each item is ordered separately
 SEHMC750 is the Hollow Chisel
 SECB-34 is the Chisel Bit (Carbon Steel)
 SECB-34HS (High Speed Steel)
 SECB-34CT (Carbide-Tipped)

Hollow Mortising Chisels • Import



Part Number	Diameter	Shoulder Diameter	Overall Length
SEHMC250	1/4"	5/8"	5-1/4"
SEHMC375	3/8"	5/8"	5-1/2"
SEHMC500	1/2"	5/8"	5-1/2"
SEHMC625	5/8"	3/4"	6"

Each Chisel 1/4" thru 5/8" comes with the center drill

Carving Rougher Bits

High-Speed Steel



M2 Steel

Part Number	Diameter	Rotation	Shank
SECR500RH	1/2"	RH	1/4"
SECR500LH	1/2"	LH	1/4"
SECR625RH	5/8"	RH	1/4"
SECR625LH	5/8"	LH	1/4"
SECR625RH-11	5/8"	RH	11mm
SECR625LH-11	5/8"	LH	11mm
SECR750RH	3/4"	RH	1/4"
SECR750LH	3/4"	LH	1/4"
SECR750RH-11	3/4"	RH	11mm
SECR750LH-11	3/4"	LH	11mm
SECR750RH-12	3/4"	RH	1/2"
SECR750LH-12	3/4"	LH	1/2"
SECR1000RH	1"	RH	1/4"
SECR1000LH	1"	LH	1/4"

Roundnose Carving Bits



M2 Steel

High-Speed Steel

Part Number	Diameter	Rotation	Shank
SERC500RH	1/2"	RH	1/4"
SERC500LH	1/2"	LH	1/4"
SERC750RH	3/4"	RH	1/4"
SERC750LH	3/4"	LH	1/4"

Carving Pod Bits



M2 Steel

High-Speed Steel

Part Number	Diameter	Cutting Length	Rotation	Overall Length
SEPD125LH	1/8"	3/4"	LH	3"
SEPD125RH	1/8"	3/4"	RH	3"
SEPD187LH	3/16"	1"	LH	3"
SEPD187RH	3/16"	1"	RH	3"
SEPD250LH	1/4"	1"	LH	3"
SEPD250RH	1/4"	1"	RH	3"
SEPD375LH	3/8"	1"	LH	3"
SEPD375RH	3/8"	1"	RH	3"

Square Corner Chisel

SE9600



Part Number	Radius
SE9600	1/4"

1

2

3

4

5

6

7

8

9

10

Carbide-Tipped 3 Wing Drills

CAUTION: TO BE USED IN A DRILL PRESS, MILLING MACHINE OR BORING MACHINE



SDR350



SDR410

*Full Shanks on Bits up to and including SDR350
Special sizes available, call for a quote.
Add F to end of part number for 1 Flat on Shank
Add F3 to end of part number for 3 Flats on Shank
These drills can be re-tipped, call for pricing.*

Part Number	Diameter	Overall Length	Shank
SDR290	1/2"	6"	1/2"
SDR295	9/16"	6"	1/2"
SDR305	5/8"	6"	1/2"
SDR303	11/16"	6"	1/2"
SDR300	3/4"	6"	1/2"
SDR310	7/8"	6"	1/2"
SDR315	15/16"	6"	1/2"
SDR320	1"	6"	1/2"
SDR325	1-1/16"	6"	1/2"
SDR330	1-1/8"	6"	1/2"
SDR340	1-1/4"	6"	1/2"
SDR350	1-3/8"	6"	1/2"
SDR360	1-1/2"	6"	1/2"
SDR370	1-5/8"	6"	1/2"
SDR380	1-3/4"	6"	1/2"
SDR390	1-7/8"	6"	1/2"
SDR400	2"	6"	1/2"
SDR410	2-1/8"	6"	1/2"
SDR413	2-1/4"	6"	1/2"
SDR414	2-3/8"	6"	1/2"
SDR415	2-1/2"	6"	1/2"
SDR424	2-15/16"	6"	1/2"
SDR425	3"	6"	1/2"
SDR430	3-1/4"	6"	1/2"
SDR440	3-3/4"	6"	1/2"

Replacement Parts

SDR-DRILL - Replacement Center Drill
SDR - SCREW - Replacement Screw

Carbide-Tipped 3 Wing Drills • Quick Change

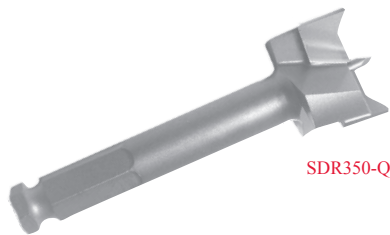

SDR350-QCF

Used for fiberglass cutting in the boat or RV

Part Number	Diameter	Overall Length	Shank
SDR300-QCF	3/4"	3-3/4"	1/2"
SDR310-QCF	7/8"	3-3/4"	1/2"
SDR320-QCF	1"	3-7/8"	1/2"
SDR325-QCF	1-1/16"	3-7/8"	1/2"
SDR330-QCF	1-1/8"	3-7/8"	1/2"
SDR340-QCF	1-1/4"	3-7/8"	1/2"
SDR345-QCF	1-5/16"	3-7/8"	1/2"
SDR350-QCF	1-3/8"	3-7/8"	1/2"
SDR360-QCF	1-1/2"	3-7/8"	1/2"
SDR390-QCF	1-7/8"	3-7/8"	1/2"

Carbide-Tipped Door Knob 3 Wing Drill

CAUTION: TO BE USED IN A DRILL PRESS, MILLING MACHINE OR BORING MACHINE



SDK500

Part Number	Diameter	Shank	Overall Length	Description
SDK500	2-1/8"	1/2"	5-3/4"	No Flat
SDK510	2-1/8"	1/2"	5-3/4"	With Flat
SDK510-750	2-1/8"	3/4"	5-3/4"	With Flat

Replacement Parts

SDK560 - Center Drill
SDK565 - Set Screw

Carbide-Tipped Door Bits

FOR AUTOMATED PRE-HUNG DOOR EQUIPMENT



SLOC600

Part Number	Description	Diameter	Shank	Overall Length
SLOC600	With Flat on Shank	2-1/8"	1/2"	5-3/4"
SLOC605	3 Flats on Shank	2-1/8"	1/2"	5-3/4"
SLOC610	Without Flat	2-1/8"	1/2"	5-3/4"

Replacement Parts

SDR-DRILL - Replacement Center Drill

SDR - SCREW - Replacement Screw

High Speed Steel Multi-Spur Bits



SMSHS435

All bits have a 1/2" Shank unless noted.

6" Overall Length
Made in Austria

Part Number	Diameter
SMSHS300	3/4"
SMSHS305	13/16"
SMSHS310	7/8"
SMSHS315	15/16"
SMSHS321	1"
SMSHS325	1-1/16"
SMSHS330	1-1/8"
SMSHS335	1-3/16"
SMSHS340	1-1/4"
SMSHS345	1-5/16"
SMSHS350	1-3/8"
SMSHS355	1-7/16"
SMSHS360	1-1/2"
SMSHS365	1-9/16"
SMSHS370	1-5/8"
SMSHS375	1-11/16"
SMSHS380	1-3/4"
SMSHS385	1-13/16"
SMSHS390	1-7/8"
SMSHS395	1-15/16"

Part Number	Diameter
SMSHS400	2"
SMSHS411	2-1/8"
SMSHS413	2-1/4"
SMSHS414	2-3/8"
SMSHS415	2-1/2"
SMSHS420	2-5/8"
SMSHS425	2-3/4"
SMSHS430	2-7/8"
SMSHS435	3"
*SMSHS440-34	3 1/8"
SMSHS440	3-1/8"
*SMSHS445-34	3-1/4"
SMSHS445	3-1/4"
*SMSHS450-34	3-1/2"
SMSHS450	3-1/2"
*SMSHS455-34	3-3/4"
SMSHS455	3-3/4"
*SMSHS460-34	4"
SMSHS460	4"

*3/4" shank

Carbide-Tipped Multi-Spur Bits

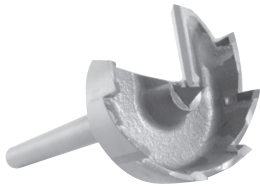

SMS410

All bits have a 1/2" Shank unless noted.

6" Overall Length
Made in USA

Part Number	Diameter
SMS300	3/4"
SMS305	13/16"
SMS310	7/8"
SMS315	15/16"
SMS321	1"
SMS325	1-1/16"
SMS330	1-1/8"
SMS335	1-3/16"
SMS340	1-1/4"
SMS345	1-5/16"
SMS350	1-3/8"
SMS355	1-7/16"
SMS360	1 1/2"
SMS365	1-9/16"
SMS370	1-5/8"
SMS375	1-11/16"
SMS380	1-3/4"
SMS385	1-13/16"
SMS390	1-7/8"
SMS395	1-15/16"

Part Number	Diameter
SMS400	2"
SMS411	2-1/8"
SMS413	2-1/4"
SMS414	2-3/8"
SMS415	2-1/2"
SMS420	2-5/8"
SMS425	2-3/4"
SMS430	2-7/8"
SMS435	3"
*SMS440-34	3-1/8"
SMS440	3-1/8"
*SMS445-34	3-1/4"
SMS445	3-1/4"
*SMS450-34	3-1/2"
SMS450	3-1/2"
*SMS455-34	3-3/4"
SMS455	3-3/4"
*SMS460-34	4"
SMS460	4"

*3/4" shank

Import	
Part Number	Description
SMS320	C/T Multi Spur 1" Dia
SMS410	C/T Multi Spur 2-1/8" Dia

1

2

3

4

5

6

7

8

9

10

Carbide-Tipped Economy Door Bits



SE6100

Part Number	Diameter	Overall Length	Shank	
SE6100	2-1/8"	6"	1/2"	
SE6100F	2-1/8"	6"	1/2"	With Flat

Carbide-Tipped Latch Bits

FOR AUTOMATED PRE-HUNG DOOR EQUIPMENT



SLAT780



SLAT790

Part Number	Description	Diameter	Shank	Overall Length
SLAT670	Without Flat	7/8"	1/2"	6"
SLAT680	With Flat	7/8"	1/2"	6"
SLAT690	Threaded	7/8"	7/16" Thread	5-7/8"
SLAT720	Without Flat	15/16"	1/2"	6"
SLAT730	With Flat	15/16"	1/2"	6"
SLAT740	Threaded	15/16"	7/16" Thread	5-7/8"
SLAT770	Without Flat	1"	1/2"	6"
SLAT780	With Flat	1"	1/2"	6"
SLAT790	Threaded	1"	7/16" Thread	5-7/8"
SLAT800	Without Flat	1-1/16"	1/2"	6"
SLAT810	With Flat	1-1/16"	1/2"	6"
SLAT820	Threaded	1-1/16"	7/16" Thread	5-7/8"

Other sizes available including threaded shank.

Carbide-Tipped Brad Point Twist Drills



SBPT1

Part Number	Drill Diameter	Twist Length	Shank	Overall Length	Description
SBPT1	1"	4"	1/2"	6"	No Flat
SBPT1F	1"	4"	1/2"	6"	With Flat
SBPT1T	1"	4"	7/16-14"	5 13/16"	Threaded

Carbide-Tipped Face Frame Bits



SFFB700



SFFB800

Part Number	Description	Diameter	Pilot Drill	Overall Length
SFFB700	Complete Assembly	3/8"	#29	4"
SFFB800	Complete Assembly	3/8"	#29	4"
NEW * SFFB900	Complete Assembly	3/8"	#29	6"
SFFB710	#29 Pilot Drill Only			
SFFB720	Replacement Set Screw			

*For: Evans®, Ritter®, Unique®, Marcon® and Norfield® Face Frame Machines
* Kreg® Machine*

Drills

CARBIDE-TIPPED ADJUSTABLE COUNTERSINK, STYLE 4CT

Designed for countersinking holes for flat-head screws.

Recommended for use in any wood product containing glue, or long production runs in hardwood.

Performs well in many plastics, as well as in several composite materials, including fiberglass.

Center drill is held in place with set screws.

Please note that center drills are not included in the sale of countersinks.

Part Number	Countersink Diameter	Center Drill Diameter	Shank Dia. x Length	Overall Length
SE144000	3/8"	3/16"	1/2" x 3/8"	1-1/4"
SE14400	1/2"	1/8"		1-1/4"
SE14401	1/2"	3/16"		1-1/4"
SE14402	1/2"	7/32"		1-1/4"
SE14403	1/2"	1/4"		1-1/4"
SE144030	1/2"	5/16"	5/8" x 3/8"	1-1/4"



TAPER SHELL COUNTERSINK, STYLE 4

Designed for countersinking holes for flat-head screws.

Center drill is held in place with set screws.

Carbon steel.

Please note that center drills are not included in the sale of countersinks.

Part Number	Countersink Diameter	Center Drill Diameter	Shank Dia. x Length	Overall Length
SE10400	3/8"	1/8"	1/2" x 3/8"	1-1/4"
SE10401	3/8"	3/16"	1/2" x 3/8"	1-1/4"
SE10402	1/2"	1/8"		1-1/4"
SE10404	1/2"	5/32"		1-1/4"
SE10406	1/2"	3/16"		1-1/4"
SE10408	1/2"	7/32"		1-1/4"
SE10409	1/2"	1/4"		1-1/4"
SE104094	1/2"	5/16"	5/8" x 3/8"	1-1/4"
SE10410	5/8"	1/4"		1-1/4"
SE10411	5/8"	5/16"		1-1/4"
SE10412	3/4"	5/16"		1-1/4"
SE10413	3/4"	3/8"		1-1/4"



1

2

3

4

5

6

7

8

9

10

Drills

ADJUSTABLE COUNTERBORE, STYLE NO. 5

Designed for counterboring flat-bottom holes.

Overall length is 4-1/2". Shank diameter is 1/2".

Carbon Steel

Please note that center drills are not included in the sale of counterbores.

Part Number	Counterbore Diameter	Center Drill Hole Diameter	Cutting Length	Shank Length
SE10501	3/8"	1/8"	3"	1-1/2"
SE10502	3/8"	5/32"	3"	1-1/2"
SE10503	3/8"	3/16"	3"	1-1/2"
SE105032	3/8"	3/16"	2-1/2"	2"
SE10504	7/16"	5/32"	3"	1-1/2"
SE10505	7/16"	3/16"	3"	1-1/2"
SE10506	7/16"	7/32"	3"	1-1/2"
SE10507	7/16"	1/4"	3"	1-1/2"
SE10508	1/2"	1/8"	3"	1-1/2"
SE10509	1/2"	5/32"	3"	1-1/2"
SE10510	1/2"	11/64"	3"	1-1/2"
SE10511	1/2"	3/16"	3"	1-1/2"
SE10512	1/2"	13/64"	3"	1-1/2"
SE10513	1/2"	7/32"	3"	1-1/2"
SE10514	1/2"	1/4"	3"	1-1/2"
SE10516	9/16"	3/16"	3"	1-1/2"
SE10518	9/16"	1/4"	3"	1-1/2"
SE10519	9/16"	9/32"	3"	1-1/2"
SE10520	5/8"	5/32"	3"	1-1/2"
SE10521	5/8"	3/16"	3"	1-1/2"
SE10522	5/8"	7/32"	3"	1-1/2"
SE10523	5/8"	1/4"	3"	1-1/2"
SE10524	5/8"	9/32"	3"	1-1/2"
SE10525	5/8"	5/16"	3"	1-1/2"
SE10526	11/16"	1/4"	3"	1-1/2"
SE10528	11/16"	5/16"	3"	1-1/2"
SE10529	3/4"	3/16"	3"	1-1/2"
SE10530	3/4"	7/32"	3"	1-1/2"
SE10531	3/4"	1/4"	3"	1-1/2"
SE10532	3/4"	9/32"	3"	1-1/2"
SE10533	3/4"	5/16"	3"	1-1/2"
SE10534	3/4"	3/8"	3"	1-1/2"
SE10536	13/16"	1/4"	3"	1-1/2"
SE10538	13/16"	5/16"	3"	1-1/2"
SE10539	7/8"	3/16"	3"	1-1/2"
SE10541	7/8"	1/4"	3"	1-1/2"
SE10542	7/8"	5/16"	3"	1-1/2"
SE10543	7/8"	3/8"	3"	1-1/2"
SE10544	1"	1/4"	3"	1-1/2"
SE10545	1"	5/16"	3"	1-1/2"
SE10546	1"	3/8"	3"	1-1/2"
SE10547	1-1/8"	1/4"	3"	1-1/2"
SE10549	1-1/8"	3/8"	3"	1-1/2"
SE10550	1-1/4"	1/4"	3"	1-1/2"
SE10552	1-1/4"	3/8"	3"	1-1/2"



Center drills are not included.

5 Adjustable Counterbore

Drills

ADJUSTABLE COUNTERBORE, STYLE NO. 5A

Designed for counterboring flat-bottom holes.

Drill is held in place with two opposing set screws.

Carbon Steel.

Please note that center drills are not included in the sale of counterbores.

Part Number	Counterbore Diameter	Center Drill Hole Diameter	Overall Length
SE15301	3/8"	3/16"	1-1/2"
SE153001	7/16"	3/16"	1-1/2"
SE153002	7/16"	7/32"	1-1/2"
SE15302	1/2"	3/16"	1-1/2"
SE15303	1/2"	7/32"	1-1/2"
SE15304	1/2"	1/4"	1-1/2"
SE15305	5/8"	1/4"	1-1/2"
SE15306	5/8"	5/16"	1-1/2"
SE15307	3/4"	1/4"	2"
SE15308	3/4"	5/16"	2"
SE15309	7/8"	1/4"	2"
SE15310	7/8"	5/16"	2"
SE15311	7/8"	3/8"	2"
SE15312	7/8"	7/16"	2"
SE15313	1"	1/4"	2"
SE15314	1"	5/16"	2"
SE15315	1"	3/8"	2"
SE15316	1"	7/16"	2"
SE15317	1"	1/2"	2"
SE15318	1-1/8"	*5/16" x 1/2"	2"
SE15319	1-1/8"	*3/8" x 1/2"	2"
SE15320	1-1/8"	7/16"	2"
SE15321	1-1/8"	1/2"	2"
SE15322	1-1/4"	*5/16" x 1/2"	2"
SE15323	1-1/4"	*3/8" x 1/2"	2"
SE15324	1-1/4"	7/16"	2"
SE15325	1-1/4"	1/2"	2"
SE15326	1-3/8"	*3/8" x 1/2"	2"
SE15328	1-3/8"	1/2"	2"
SE15329	1-1/2"	*3/8" x 1/2"	2"
SE15330	1-1/2"	*7/16" x 1/2"	2"
SE15331	1-1/2"	1/2"	2"
SE15332	1-1/2"	9/16"	2"
SE15333	1-1/2"	5/8"	2"
SE15334	1-5/8"	1/2"	2"
SE15335	1-3/4"	1/2"	2"

**Indicates a stepped hole diameter allowing the tool to be clamped to a 1/2" shank drill.*

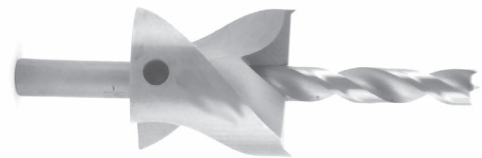

Center drills are for reference

5A Adjustable Counterbore

1

2

3

4

5

6

7

8

9

10

Drills

COUNTERSINK DRILLS, STYLE 5B

For use with adjustable style counterbores, and countersinks.

6" overall length.

Made from high-speed steel.

Part Number	Cutting Diameter	Cutting Length	Shank Diameter	Shank Length
SE50300BP	3/16"	2-1/4"	1/8"	4"
SE503001BP	7/32"	2-1/4"	3/16"	3-3/4"
SE503010**	5/16"	1-1/2"	1/4"	4-1/2"
SE50301BPHS	5/16"	1-1/2"	1/4"	4-1/2"
SE50302BPHS	3/8"	1-1/2"	1/4"	4-1/2"
SE503025**	3/8"	1-1/2"	1/4"	4-1/2"
SE50303BPHS	7/16"	1-1/2"	1/4"	4-1/2"
SE50305BPHS	1/2"	1-1/2"	1/4"	4-1/2"

****Tools with asterisks after the stock number would have a drill-point.
All other tools listed are brad-points.**



5B Adjustable Counterbore

BRAD-POINT DRILL, STYLE 5BLHS

Designed for use in bed-lock machines.

Right-hand rotation.

Made from high-speed steel.

Part Number	Cutting Diameter	Cutting Length	Shank Length	Overall Length
SE50134	19/64"	4"	2"	6"
SE50135	9/32"	4"	2"	6"



5BLHS Brad-Point

COUNTERSINK BRAD-POINT DRILL, STYLE 5BPHS

Shank same size as diameter.

Made from high-speed steel.

Part Number	Cutting Diameter	Cutting Length	Shank Length	Overall Length
SE50216	1/8"	2-1/2"	3-1/2"	6"
SE50217	5/32"	2-1/2"	3-1/2"	6"
SE50218	3/16"	2-1/2"	3-1/2"	6"
SE50220	7/32"	2-1/2"	3-1/2"	6"
SE50221	1/4"	2-1/2"	3-1/2"	6"
SE50223	9/32"	2-1/2"	3-1/2"	6"
SE50224	5/16"	2-1/2"	3-1/2"	6"
SE502242	11/32"	2-1/2"	3-1/2"	6"
SE50225	3/8"	2-1/2"	3-1/2"	6"

Other sizes available.



5BPHS Countersink Brad-Point

Drills

COUNTERSINK BRAD-POINT DRILL, STYLE NO. 5BPHS-LH

Left-hand rotation.

Made from high-speed steel.

Part Number	Cutting Diameter	Cutting Length	Shank Length	Overall Length
SE50226	3/16"	2-1/2"	3-1/2"	6"
SE50227	7/32"	2-1/2"	3-1/2"	6"
SE50228	1/4"	2-1/2"	3-1/2"	6"



5BPHS-LH Countersink Brad-Point

CARBIDE-TIPPED COUNTERBORE, STYLE NO. 5CT

Designed for counterboring flat-bottom holes.

Recommended for use in any wood product containing glue, or long production runs in hardwood.

Performs well in many plastics, as well as in several composite materials, including fiberglass.

Shank length is 1 1/2" x 1/2" diameter.

Please note that center drills are not included in the sale of counterbores.

Part Number	Counterbore Diameter	Center Drill Hole Diameter	Cutting Length	Overall Length
SE15701	3/8"	3/16"	3"	4-1/2"
SE157012	7/16"	3/16"	3"	4-1/2"
SE157013	7/16"	7/32"	3"	4-1/2"
SE15702	1/2"	3/16"	3"	4-1/2"
SE15703	1/2"	7/32"	3"	4-1/2"
SE15704	1/2"	1/4"	3"	4-1/2"



Center drills are not included.

5CT Counterbore

CARBIDE-TIPPED COUNTERSINK, STYLE NO. 5CT

Designed for countersinking holes for flat-head screws.

Recommended for use in any wood product containing glue, or long production runs in hardwood.

Performs well in many plastics, as well as in several composite materials, including fiberglass.

Shank length is 1 1/2" x 1/2" diameter.

Please note that center drills are not included in the sale of counterbores.

Part Number	Counterbore Diameter	Center Drill Hole Diameter	Cutting Length	Overall Length
SE15801	3/8"	3/16"	3"	4-1/2"
SE158011	7/16"	3/16"	3"	4-1/2"
SE158012	7/16"	7/32"	3"	4-1/2"
SE15802	1/2"	3/16"	3"	4-1/2"
SE15803	1/2"	7/32"	3"	4-1/2"
SE15804	1/2"	1/4"	3"	4-1/2"



Center drills are not included.

5CT Countersink

1

2

3

4

5

6

7

8

9

10

Drills

1

SHORT-LENGTH COUNTERSINKS, STYLE NO. 5C

Designed for countersinking holes for flat-head screws.

Shank diameter is 1/2" x 1-1/2" long.

Please note that center drills are not included in the sale of countersinks.

Part Number	Countersink Diameter	Center Drill Diameter	Cutting Length	Overall Length
SE152011	3/8"	3/16"	1-1/2"	3"
SE15201	1/2"	3/16"	1-1/2"	3"
SE15202	1/2"	7/32"	1-1/2"	3"
SE15203	1/2"	1/4"	1-1/2"	3"

Center drills are not included.



5C Short Length Countersink

2

ADJUSTABLE COUNTERSINK, STYLE NO. 5C

Designed for countersinking holes for flat-head screws.

Overall length is 4-1/2". Shank diameter is 1/2".

Please note that center drills are not included in the sale of countersinks.

Part Number	Countersink Diameter	Center Drill Diameter	Cutting Length	Shank Length
SE15101	3/8"	1/8"	3"	1-1/2"
SE15102	3/8"	5/32"	3"	1-1/2"
SE15103	3/8"	3/16"	3"	1-1/2"
SE151032	3/8"	3/16"	2-1/2"	2"
SE15105	7/16"	3/16"	3"	1-1/2"
SE15106	7/16"	7/32"	3"	1-1/2"
SE15108	1/2"	1/8"	3"	1-1/2"
SE15109	1/2"	5/32"	3"	1-1/2"
SE15110	1/2"	11/64"	3"	1-1/2"
SE15111	1/2"	3/16"	3"	1-1/2"
SE15112	1/2"	13/64"	3"	1-1/2"
SE15113	1/2"	7/32"	3"	1-1/2"
SE15114	1/2"	1/4"	3"	1-1/2"
SE151142	1/2"	1/4"	2-1/2"	2"

Center drills are not included.



5C Adjustable Countersink

4

5

SOLID COUNTERBORE, STYLE NO. 5DHS STEP DRILL • 1 PIECE

Overall length is 5-1/2". Shank is 1/2" in diameter x 2" long.

Point Style: Small diameter brad-point, large diameter counterbore.

Made in high speed steel.

Part Number	Large Diameter	Large Diameter Cutting Length	Small Diameter	Small Diameter Cutting Length
SE155004HS	3/8"	2"	3/16"	1-1/2"
SE155005HS	7/16"	2"	3/16"	1-1/2"
SE155006HS	7/16"	2"	7/32"	1-1/2"
SE15501HS	1/2"	2"	3/16"	1-1/2"
SE15503HS	1/2"	2"	1/4"	1-1/2"

5DHS Solid Counterbore



7

8

SOLID COUNTERSINK, STYLE NO. 5EHS STEP DRILL • 1 PIECE

Designed for countersinking holes for flat-head screws.

Overall length is 5-1/2". Shank is 1/2" in diameter x 2" long.

Tapered cut. Made in High Speed Steel.

Part Number	Large Diameter	Large Diameter Flute Length	Small Diameter	Small Diameter Flute Length
SE15600HS	3/8"	2"	3/16"	1-1/2"
SE15697HS	7/16"	2"	3/16"	1-1/2"
SE15601HS	1/2"	2"	3/16"	1-1/2"
SE15603HS	1/2"	2"	1/4"	1-1/2"

5EHS Solid Countersink



10

Drills

COUNTERSINK DRILL-POINT DRILLS, STYLE NO. 5HS

Made from high-speed steel.

Part Number	Cutting Diameter	Cutting Length	Shank Length	Overall Length
SE502001	3/32"	2-1/2"	3-1/2"	6"
SE50201	1/8"	2-1/2"	3-1/2"	6"
SE50202	5/32"	2-1/2"	3-1/2"	6"
SE50204	3/16"	2-1/2"	3-1/2"	6"
SE50206	7/32"	2-1/2"	3-1/2"	6"
SE50207	1/4"	2-1/2"	3-1/2"	6"
SE50209	9/32"	2-1/2"	3-1/2"	6"
SE50211	5/16"	2-1/2"	3-1/2"	6"
SE502111	11/32"	2-1/2"	3-1/2"	6"
SE50212	3/8"	2-1/2"	3-1/2"	6"
NEW SE50219	13/64"	2-1/2"	3-1/2"	6"
NEW SE50222	19/64"	2-1/2"	3-1/2"	6"

Other sizes available.



Style 5HS

COUNTERSINK DRILL-POINT DRILLS, STYLE NO. 5HSLH

Left-hand rotation.

Made from high-speed steel.

Part Number	Cutting Diameter	Cutting Length	Shank Length	Overall Length
SE50213	3/16"	2-1/2"	3-1/2"	6"
SE50214	7/32"	2-1/2"	3-1/2"	6"
SE50215	1/4"	2-1/2"	3-1/2"	6"



Style 5HSLH

V-POINT COUNTERSINK DRILL, STYLE NO. 5VHS

Designed for angle drilling.

Fish-tail point.

Made from high-speed steel.

Part Number	Cutting Diameter	Cutting Length	Shank Length	Overall Length
SE50136HS	3/16"	2-1/2"	3-1/2"	6"
SE50137HS	7/32"	2-1/2"	3-1/2"	6"
SE50138HS	1/4"	2-1/2"	3-1/2"	6"



Style 5VHS

1

2

3

4

5

6

7

8

9

10

Drills

1

BRAD-POINT COUNTERSINK DRILL, STYLE NO. 5-7BPHS

Made from high-speed steel.

Part Number	Cutting Diameter	Cutting Length	Shank Length	Overall Length
SE50704	3/16"	3"	4"	7"
SE50705	7/32"	3"	4"	7"
SE50706	1/4"	3"	4"	7"



Style 5-7BPHS

2

3

DRILL-POINT DRILL, STYLE NO. 5-7HS

Made from high-speed steel.

Part Number	Cutting Diameter	Cutting Length	Shank Length	Overall Length
SE50701HS	3/16"	3"	4"	7"
SE50702HS	7/32"	3"	4"	7"
SE50703HS	1/4"	3"	4"	7"



Style 5-7HS

4

5

BRAD-POINT COUNTERSINK DRILL, STYLE NO. 5-8BPHS

Made from high-speed steel.

Part Number	Cutting Diameter	Cutting Length	Shank Length	Overall Length
SE50804	3/16"	4"	4"	8"
SE50805	7/32"	4"	4"	8"
SE50806	1/4"	4"	4"	8"



Style 5-8BPHS

6

7

8

COUNTERSINK DRILL-POINT DRILL, STYLE NO. 5-8HS

Made from high-speed steel.

Part Number	Cutting Diameter	Cutting Length	Shank Length	Overall Length
SE50801HS	3/16"	4"	4"	8"
SE50802HS	7/32"	4"	4"	8"
SE50803HS	1/4"	4"	4"	8"



Style 5-8HS

9

10

Drills

THREADED-SHANK ADJUSTABLE COUNTERBORE, STYLE NO. 514

Designed for counterboring flat-bottom holes.

Overall length is 4-1/2". Shank length is 1-1/2". Shank thread is 7/16"-14.

Please note that center drills are not included in the sale of counterbores.

Part Number	Counterbore Diameter	Center Drill Hole Diameter	Cutting Length	Rotational Direction
SE15401	3/8"	1/8"	3"	right
SE15402	3/8"	5/32"	3"	right
SE15403	3/8"	3/16"	3"	right
SE15405	7/16"	3/16"	3"	right
SE15406	7/16"	7/32"	3"	right
SE15407	7/16"	1/4"	3"	right
SE15408	1/2"	5/32"	3"	right
SE15409	1/2"	3/16"	3"	right
SE15410	1/2"	7/32"	3"	right
SE15411	1/2"	1/4"	3"	right
SE15412	5/8"	3/16"	3"	right
SE15413	3/4"	3/16"	3"	right
SE15414	3/4"	7/32"	3"	right
SE15415	3/4"	1/4"	3"	right
SE15417	3/8"	3/16"	3"	left
SE15418	7/16"	3/16"	3"	left
SE15420	1/2"	3/16"	3"	left
SE15421	1/2"	7/32"	3"	left
SE15422	1/2"	1/4"	3"	left
SE15426	3/4"	1/4"	3"	left



Center drills are not included.

Style 514 Counterbore

THREADED-SHANK ADJUSTABLE COUNTERSINK, STYLE NO. 514C

Designed for countersinking holes for flat-head screws.

Overall length is 4-1/2". Shank length is 1-1/2". Shank thread is 7/16"-14.

Please note that center drills are not included in the sale of countersinks.

Part Number	Countersink Diameter	Center Drill Hole Diameter	Cutting Length	Rotational Direction
SE15427	3/8"	3/16"	3"	right
SE154273	7/16"	3/16"	3"	right
SE15428	1/2"	3/16"	3"	right
SE15429	1/2"	7/32"	3"	right
SE15430	1/2"	1/4"	3"	right
SE15431	3/8"	3/16"	3"	left
SE154274	7/16"	3/16"	3"	left
SE15432	1/2"	3/16"	3"	left
SE15433	1/2"	7/32"	3"	left
SE15434	1/2"	1/4"	3"	left



Center drills are not included.

Style 514C Countersink

1

2

3

4

5

6

7

8

9

10

Drills

CARBIDE-TIPPED ADJUSTABLE COUNTERBORE, STYLE NO. 514CT

Designed for counterboring flat-bottom holes.

Recommended for use in any wood product containing glue, or long production runs in hardwood. Performs well in many plastics, as well as in several composite materials, including fiberglass.

Overall length is 4-1/2". Shank length is 1-1/2". Shank thread is 7/16"-14.

Please note that center drills are not included in the sale of counterbores.

Part Number	Counterbore Diameter	Center Drill Hole Diameter	Cutting Length	Rotational Direction
SE15901	3/8"	3/16"	3"	right
SE159012	7/16"	3/16"	3"	right
SE15902	1/2"	3/16"	3"	right
SE15903	1/2"	7/32"	3"	right
SE15904	1/2"	1/4"	3"	right
*SE15905	3/8"	3/16"	3"	left

**LH Rotation*

Center drills are not included.



Style 514CT Counterbore

MORTISING BIT, STYLE NO. 6HS 2 FLUTE • BI-DIRECTIONAL CUTTING

Designed for use on vibrating mortising machines.

Made from high speed steel.

Part Number	Cutting Diameter	Cutting Length	Shank Diameter	Overall Length
SE60001HS	1/4"	2"	1/2"	4-1/2"
SE600014HS	1/4"	1-1/4"	1/2"	3-1/4"
SE60002HS	5/16"	2"	1/2"	4-1/2"
SE60003HS	3/8"	2"	1/2"	4-1/2"
SE60004HS	1/2"	2-1/4"	1/2"	4-1/2"



Style 6HS

VIBRATING MORTISE BIT, STYLE NO. 46HS 2 FLUTE • BI-DIRECTIONAL CUTTING

Designed for use on vibrating mortising machines.

Made from high speed steel.

Part Number	Flute Diameter	Flute Length	Shank Diameter	Overall Length
SE46001HS	1/4"	2"	1/4"	4"
SE46002HS	5/16"	2"	5/16"	4"
SE46003HS	3/8"	2-1/2"	3/8"	4-1/2"
SE46004HS	7/16"	2-1/2"	7/16"	4-1/2"



Style 46HS

Drills

BRAD-POINT DRILL, STYLE NO. 8BPHS

Made from high-speed steel.

Part Number	Cutting Diameter	Cutting Length	Shank Length	Overall Length
SE80210	1/8"	2-1/4"	2-1/4"	4-1/2"
SE80211	5/32"	2-1/4"	2-1/4"	4-1/2"
SE80212	3/16"	2-1/4"	2-1/4"	4-1/2"
SE80213	7/32"	2-1/4"	2-1/4"	4-1/2"
SE80214	1/4"	2-1/4"	2-1/4"	4-1/2"
SE80217	5/16"	2-1/4"	2-1/4"	4-1/2"
SE80218	3/8"	2-1/4"	2-1/4"	4-1/2"

Other sizes available.



Style 8BPHS

TAPER COUNTERSINK, STYLE NO. 8

Designed for countersinking holes for flat-head screws.

Overall length 3".

Carbon Steel.

Center drill is held in place with a set screw.

Please note that center drills are not included in the sale of countersinks.

Part Number	Countersink Diameter	Center Drill Diameter	Shank Length	Shank Diameter
SE10801	3/8"	3/16"	1-1/2"	1/2"
SE108010	7/16"	3/16"	1-1/2"	1/2"
SE108000	7/16"	7/32"	1-1/2"	1/2"
SE10802	1/2"	3/32"	1-1/2"	1/2"
SE10803	1/2"	1/8"	1-1/2"	1/2"
SE10805	1/2"	5/32"	1-1/2"	1/2"
SE10807	1/2"	3/16"	1-1/2"	1/2"
SE10809	1/2"	7/32"	1-1/2"	1/2"
SE10810	1/2"	1/4"	1-1/2"	1/2"
SE108104	1/2"	5/16"	1-1/2"	1/2"
SE10817	5/8"	5/16"	1-1/2"	1/2"
SE10820	3/4"	5/16"	1-1/2"	1/2"



Style 8

BRAD-POINT DRILL, STYLE NO. 8BPHSLH

Left-hand rotation.

Made from high-speed steel.

Part Number	Cutting Diameter	Cutting Length	Shank Length	Overall Length
SE80212L	3/16"	2"	2-1/2"	4-1/2"
SE80213L	7/32"	2"	2-1/2"	4-1/2"
SE80214L	1/4"	2"	2-1/2"	4-1/2"



Style 8BPHSLH

1

2

3

4

5

6

7

8

9

10

Drills

1

CARBIDE-TIPPED COUNTERSINK, STYLE NO. 8CT • 82° ANGLE

Designed for countersinking holes for flat-head screws.

Recommended for use in any wood product containing glue, or long production runs in hardwood. Performs well in many plastics, as well as in several composite materials, including fiberglass.

Overall length is 3".

Center drill is held in place with a set screw.

Please note that center drills are not included in the sale of countersinks.

Part Number	Countersink Diameter	Center Drill Diameter	Shank Length	Shank Diameter
SE18800	3/8"	3/16"	1-1/2"	1/2"
SE188001	7/16"	3/16"	1-1/2"	1/2"
SE188002	7/16"	7/32"	1-1/2"	1/2"
SE18801	1/2"	3/16"	1-1/2"	1/2"
SE18802	1/2"	7/32"	1-1/2"	1/2"
SE18803	1/2"	1/4"	1-1/2"	1/2"

Center drills are not included.



Style 8CT

2

3

4

5

DRILL-POINT DRILL, STYLE NO. 8HS

Made from high-speed steel.

Part Number	Cutting Diameter	Cutting Length	Shank Length	Overall Length
SE80200	3/32"	2-1/4"	2-1/4"	4-1/2"
SE80201	1/8"	2-1/4"	2-1/4"	4-1/2"
SE80202	5/32"	2-1/4"	2-1/4"	4-1/2"
SE80204	3/16"	2-1/4"	2-1/4"	4-1/2"
SE80205	7/32"	2-1/4"	2-1/4"	4-1/2"
SE80206	1/4"	2-1/4"	2-1/4"	4-1/2"
SE80207	9/32"	2-1/4"	2-1/4"	4-1/2"
SE80208	5/16"	2-1/4"	2-1/4"	4-1/2"
SE80209	3/8"	2-1/4"	2-1/4"	4-1/2"

Other sizes available.



Style 8HS

6

7

8

DRILL-POINT DRILL, STYLE NO. 8HSLH

Left-hand rotation.

Made from high-speed steel.

Part Number	Cutting Diameter	Cutting Length	Shank Length	Overall Length
SE802041	3/16"	2"	2-1/2"	4-1/2"
SE802051	7/32"	2"	2-1/2"	4-1/2"
SE802061	1/4"	2"	2-1/2"	4-1/2"



Style 8HSLH

9

10

Drills

MULTI-SPUR COUNTERBORE, STYLE NO. 184

CARBON TOOL STEEL • AUSTRIA.

Designed for counterbore flat-bottom holes.

Center drill is held in place with two opposing set screws.

Available with carbide tips, by special order.

Please note that center drills are not included in the sale of counterbores.

Part Number	Outside Diameter	Hole Diameter	Overall Length
SE18402	1-1/8"	1/2"	1-3/16"
SE18405	1-1/2"	1/2"	1-3/8"
SE18407	1-3/4"	1/2"	1-3/8"
SE18408	1-7/8"	1/2"	1-1/2"
SE18409	2"	1/2"	1-1/2"
SE18410	2-1/8"	1/2"	1-3/4"
SE18412	2-1/2"	1/2"	1-3/4"

Other sizes are also available, by request.

The above tools are available in carbide-tipped; call for pricing.

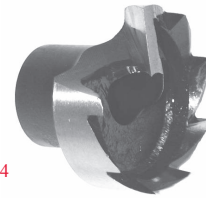

Style 184

SPIRAL PLUG CUTTER, STYLE NO. 9B

Designed with a spiral flute to be free cutting, and opened up to allow easy plug removal.

Industrial design for true size plugs, even after several sharpenings.

Made from carbon tool steel.

Part Number	Plug Cutter Diameter	Barrel Length	Shank Diameter	Overall Length
SE90001	1/4"	2"	1/2"	4"
SE90002	5/16"	2"	1/2"	4"
SE90003	3/8"	2-1/4"	1/2"	4-1/2"
SE90004	7/16"	2-1/4"	1/2"	4-1/2"
SE90005	1/2"	2-1/4"	1/2"	4-1/2"
SE90006	9/16"	2-1/4"	1/2"	4-1/2"
SE90007	5/8"	2-1/4"	1/2"	4-1/2"
SE90008	11/16"	2-1/4"	1/2"	4-1/2"
SE90009	3/4"	2-1/4"	1/2"	4-1/2"
SE90010	13/16"	2-1/4"	1/2"	4-1/2"
SE90011	7/8"	2-1/4"	1/2"	4-1/2"
SE90012	15/16"	2-1/4"	1/2"	4-1/2"
SE90013	1"	2-1/4"	1/2"	4-1/2"
SE90014	1-1/8"	2-1/4"	1/2"	4-1/2"
SE90015	1-1/4"	2-1/4"	1/2"	4-1/2"
SE90016	1-3/8"	2-1/4"	1/2"	4-1/2"
SE90017	1-1/2"	2-1/4"	1/2"	4-1/2"
SE90018	1-3/4"	2-1/4"	1/2"	4-1/2"
SE90019	2"	2-1/4"	1/2"	4-1/2"
NEW SE90022	2-1/8"	2-1/4"	1/2"	4-1/2"

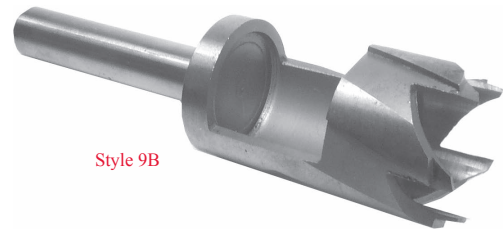

Style 9B

1

2

3

4

5

6

7

8

9

10

Drills

THREADED-SHANK DRILL-POINT DRILL, STYLE NO. 12HS • 90° POINT FOR WOODWORKING

Threaded shank is 7/16"-14.

Made from high-speed steel.

Part Number	Cutting Diameter	Cutting Length	Overall Length	Rotational Direction
SE12100A	1/8"	3"	4-1/2"	right
SE121002L	3/16"	3"	4-1/2"	left
SE121003R	3/16"	3"	4-1/2"	right
SE121004L	7/32"	3"	4-1/2"	left
SE121004R	7/32"	3"	4-1/2"	right
SE12101L	1/4"	3"	4-1/2"	left
SE12101R	1/4"	3"	4-1/2"	right
SE12102L	9/32"	3"	4-1/2"	left
SE12102R	9/32"	3"	4-1/2"	right
SE12103L	5/16"	3"	4-1/2"	left
SE12103R	5/16"	3"	4-1/2"	right
SE12105L	3/8"	3"	4-1/2"	left
SE12105R	3/8"	3"	4-1/2"	right
SE12106L	25/64"	3"	4-1/2"	left
SE12106R	25/64"	3"	4-1/2"	right
SE12107L	7/16"	3"	4-1/2"	left
SE12107R	7/16"	3"	4-1/2"	right
SE12108L	1/2"	3"	4-1/2"	left
SE12108R	1/2"	3"	4-1/2"	right

Other sizes available, call for pricing.



Style 12HS

STRAIGHT-SHANK BRAD-POINT DRILL, STYLE NO. 13

Made from high-speed steel.

Part Number	Cutting Diameter	Cutting Length	Shank Length	Overall Length
SE13001M	1/8"	1-5/8"	1-1/8"	2-3/4"
SE13002	5/32"	2"	1-1/8"	3-1/8"
SE13003M	3/16"	2-5/16"	1-3/16"	3-1/2"
SE13004	7/32"	2-1/2"	1-1/4"	3-3/4"
SE13005	1/4"	2-3/4"	1-1/4"	4"
SE13006	9/32"	2-15/16"	1-5/16"	4-1/4"
SE13007	5/16"	3-3/16"	1-5/16"	4-1/2"
SE13009	3/8"	3-5/8"	1-3/8"	5"
SE13010	7/16"	4-1/16"	1-7/16"	5-1/2"

Other sizes available.



Style 13

BRAD-POINT DRILL, STYLE NO. 13B

Made from high-speed steel.

Part Number	Cutting Diameter	Cutting Length	Shank Diameter	Overall Length
SE13101	5/16"	3-1/2"	1/4"	4-1/2"
SE13102	3/8"	3-1/2"	1/4"	4-1/2"
SE13103	7/16"	3-1/2"	1/4"	4-1/2"
SE13104	1/2"	3-1/2"	1/4"	4-1/2"

Other sizes available.



Style 13B

Drills

BRADPOINT DRILL, STYLE 13L

Made from high-speed steel.

Part Number	Cutting Diameter	Cutting Length	Shank Length	Overall Length
SE13501	1/8"	5-1/2"	2-1/2"	8"
SE13502	5/32"	5-1/2"	2-1/2"	8"
SE13503	3/16"	5-1/2"	2-1/2"	8"
SE13504	7/32"	5-1/2"	2-1/2"	8"
SE13505	1/4"	5-1/2"	2-1/2"	8"
SE13506	9/32"	5-1/2"	2-1/2"	8"
SE13507	5/16"	5-1/2"	2-1/2"	8"
SE13508	11/32"	5-1/2"	2-1/2"	8"
SE13509	3/8"	5-1/2"	2-1/2"	8"
SE13511	7/16"	5-1/2"	2-1/2"	8"
SE13513	1/2"	5-1/2"	2-1/2"	8"
SE13601	1/8"	7-1/2"	2-1/2"	10"
SE13603	3/16"	7-1/2"	2-1/2"	10"
SE13605	1/4"	7-1/2"	2-1/2"	10"
SE13607	5/16"	7-1/2"	2-1/2"	10"
SE13609	3/8"	7-1/2"	2-1/2"	10"
SE13611	7/16"	7-1/2"	2-1/2"	10"
SE13613	1/2"	7-1/2"	2-1/2"	10"
SE13701	1/8"	9"	3"	12"
SE13702	5/32"	9"	3"	12"
SE13703	3/16"	9"	3"	12"
SE13704	7/32"	9"	3"	12"
SE13705	1/4"	9"	3"	12"
SE13706	9/32"	9"	3"	12"
SE13707	5/16"	9"	3"	12"
SE13709	3/8"	9"	3"	12"
SE13711	7/16"	9"	3"	12"
SE13713	1/2"	9"	3"	12"
SE13905	1/4"	11"	4"	15"
SE13907	5/16"	11"	4"	15"
SE13909	3/8"	11"	4"	15"
SE13911	7/16"	11"	4"	15"
SE13913	1/2"	11"	4"	15"
SE13805	1/4"	14"	4"	18"
SE13807	5/16"	14"	4"	18"
SE13809	3/8"	14"	4"	18"
SE13811	7/16"	14"	4"	18"
SE13813	1/2"	14"	4"	18"

Other sizes available.



Style 13L

BRADPOINT DRILL, STYLE 13S

Designed for use in Ritter R-26 and R-38 Boring Heads.

Shank is 1/4" in diameter, 1" long, and features one flat.

Made from high-speed steel.

Part Number	Cutting Diameter	Cutting Length	Overall Length	Rotational Direction
SE13201L	5mm	1-1/2"	2-1/2"	left
SE13201R	5mm	1-1/2"	2-1/2"	right
SE13202L	1/4"	1-1/2"	2-1/2"	left
SE13202R	1/4"	1-1/2"	2-1/2"	right



Style 13S

CARBIDE-TIPPED BRAD-POINT DRILL, STYLE 13CT

Designed for use in Ritter R-26 and R-38 Boring Heads.

Recommended for use in any wood product containing glue, or long production runs in hardwood. Performs well in many plastics, as well as in several composite materials, including fiberglass.

Shank is 1/4" in diameter, 1" long, and features one flat.

Part Number	Cutting Diameter	Cutting Length	Overall Length	Rotational Direction
SE13301L	5mm	1-1/2"	2-1/2"	left
SE13301R	5mm	1-1/2"	2-1/2"	right
SE13302L	1/4"	1-1/2"	2-1/2"	left
SE13302R	1/4"	1-1/2"	2-1/2"	right



Style 13CT

1

2

3

4

5

6

7

8

9

10

Drills

1 **THREADED-SHANK BRAD-POINT DRILL, STYLE 14**

Threaded shank is 7/16"-14.

Made from carbon tool steel.

Part Number	Cutting Diameter	Cutting Length	Overall Length	Rotational Direction
NEW SE14002R	5/32"	3"	4-1/2"	right
SE14003R	3/16"	3"	4-1/2"	right
SE14004R	7/32"	3"	4-1/2"	right
SE14005R	1/4"	3"	4-1/2"	right
SE14006R	17/64"	3"	4-1/2"	right
SE14007R	9/32"	3"	4-1/2"	right
SE14008R	5/16"	3"	4-1/2"	right
SE14010R	3/8"	3"	4-1/2"	right
NEW SE14011R	25/64"	3"	4-1/2"	right
SE14012R	13/32"	3"	4-1/2"	right
SE14013R	7/16"	3"	4-1/2"	right
SE14016R	1/2"	3"	4-1/2"	right
SE14017R	33/64"	3"	4-1/2"	right
SE14019R	5/8"	3"	4-1/2"	right

LH available. Call for quote.



Style 14

5 **THREADED-SHANK BRAD-POINT DRILL, STYLE 14A**

Threaded shank is 7/16"-14.

Made from carbon tool steel.

Part Number	Cutting Diameter	Cutting Length	Overall Length	Rotational Direction
SE14024R	1/4"	2-1/4"	3-1/2"	right
SE14026R	5/16"	2-1/4"	3-1/2"	right
SE14027R	3/8"	2-1/4"	3-1/2"	right
SE14029R	7/16"	2-1/4"	3-1/2"	right
SE14031R	1/2"	2-1/4"	3-1/2"	right



Style 14A

8 **CARBIDE-TIPPED THREADED-SHANK BRAD-POINT DRILL, STYLE 14ACT**

Recommended for use in any wood product containing glue, or long production runs in hardwood. Performs well in many plastics, as well as in several composite materials, including fiberglass.

Threaded shank is 7/16"-14.

Part Number	Cutting Diameter	Cutting Length	Overall Length	Rotational Direction
SE14211L	1/4"	2-1/4"	3-1/2"	left
SE14211R	1/4"	2-1/4"	3-1/2"	right
SE14212L	5/16"	2-1/4"	3-1/2"	left
SE14212R	5/16"	2-1/4"	3-1/2"	right
SE14213L	3/8"	2-1/4"	3-1/2"	left
SE14213R	3/8"	2-1/4"	3-1/2"	right
SE14215L	7/16"	2-1/4"	3-1/2"	left
SE14215R	7/16"	2-1/4"	3-1/2"	right
SE14216L	1/2"	2-1/4"	3-1/2"	left
SE14216R	1/2"	2 1/4"	3 1/2"	right

Other sizes available.



Style 14ACT

Drills

THREADED-SHANK BRAD-POINT DRILL, STYLE 14AHS

Threaded shank is 7/16"-14.

Made from high-speed steel.

Part Number	Cutting Diameter	Cutting Length	Overall Length	Rotational Direction
SE141172L	7/32"	2-1/4"	3-1/2"	left
SE141172R	7/32"	2-1/4"	3-1/2"	right
SE14117L	1/4"	2-1/4"	3-1/2"	left
SE14117R	1/4"	2-1/4"	3-1/2"	right
SE14118L	9/32"	2-1/4"	3-1/2"	left
SE14118R	9/32"	2-1/4"	3-1/2"	right
SE14119L	5/16"	2-1/4"	3-1/2"	left
SE14119R	5/16"	2-1/4"	3-1/2"	right
SE14120L	3/8"	2-1/4"	3-1/2"	left
SE14120R	3/8"	2-1/4"	3-1/2"	right
SE14121L	25/64"	2-1/4"	3-1/2"	left
SE14121R	25/64"	2-1/4"	3-1/2"	right
SE14122L	7/16"	2-1/4"	3-1/2"	left
SE14122R	7/16"	2-1/4"	3-1/2"	right
SE141221L	29/64"	2-1/4"	3-1/2"	left
SE141221R	29/64"	2-1/4"	3-1/2"	right
SE14123L	1/2"	2-1/4"	3-1/2"	left
SE14123R	1/2"	2-1/4"	3-1/2"	right
SE141231L	9/16"	2-1/4"	3-1/2"	left
SE141231R	9/16"	2-1/4"	3-1/2"	right
SE14124L	5/8"	2-1/4"	3-1/2"	left
SE14124R	5/8"	2-1/4"	3-1/2"	right
SE14125L	3/4"	2-1/4"	3-1/2"	left
SE14125R	3/4"	2-1/4"	3-1/2"	right

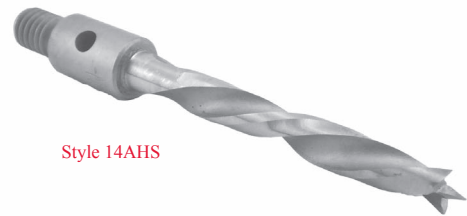

THREADED-SHANK METRIC BRAD-POINT DRILL, STYLE 14AHS

Threaded shank is 7/16"-14.

Made from high-speed steel.

Part Number	Cutting Diameter	Cutting Length	Overall Length	Rotational Direction
SE141170L	6mm	2-1/4"	3-1/2"	left
SE141170R	6mm	2-1/4"	3-1/2"	right
SE141191L	8mm	2-1/4"	3-1/2"	left
SE141191R	8mm	2-1/4"	3-1/2"	right
SE141212L	10mm	2-1/4"	3-1/2"	left
SE141212R	10mm	2-1/4"	3-1/2"	right
SE1412201L	12mm	2-1/4"	3-1/2"	left
SE1412201R	12mm	2-1/4"	3-1/2"	right
SE1412301L	13mm	2-1/4"	3-1/2"	left
SE1412301R	13mm	2-1/4"	3-1/2"	right

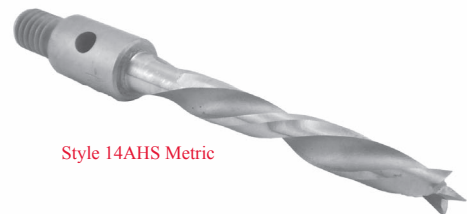

- 1
- 2
- 3
- 4
- 5
- 6
- 7
- 8
- 9
- 10

Drills

THREADED-SHANK BRAD-POINT DRILL, STYLE NO. 14BHS

Threaded shank is 7/16"-14.

Made from high-speed steel.

Part Number	Cutting Diameter	Cutting Length	Overall Length	Rotational Direction
SE14126L	1/4"	1-3/4"	3"	left
SE14126R	1/4"	1-3/4"	3"	right
SE14128L	5/16"	1-3/4"	3"	left
SE14128R	5/16"	1-3/4"	3"	right
SE14129L	3/8"	1-3/4"	3"	left
SE14129R	3/8"	1-3/4"	3"	right
SE14131L	7/16"	1-3/4"	3"	left
SE14131R	7/16"	1-3/4"	3"	right
SE14132L	1/2"	1-3/4"	3"	left
SE14132R	1/2"	1-3/4"	3"	right

Other sizes available.

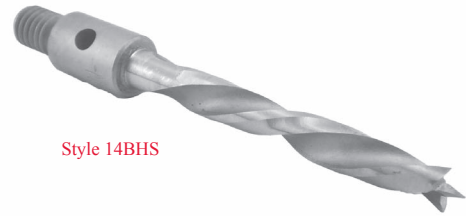

Style 14BHS

CARBIDE-TIPPED THREADED-SHANK BRAD-POINT DRILLS, STYLE NO. 14CT

Recommended for use in any wood product containing glue, or long production runs in hardwood. Performs well in many plastics, as well as in several composite materials, including fiberglass.

Threaded shank is 7/16"-14.

Part Number	Cutting Diameter	Cutting Length	Overall Length	Rotational Direction
SE14201L	1/4"	3"	4-1/2"	left
SE14201R	1/4"	3"	4-1/2"	right
SE14202L	9/32"	3"	4-1/2"	left
SE14202R	9/32"	3"	4-1/2"	right
SE14203L	5/16"	3"	4-1/2"	left
SE14203R	5/16"	3"	4-1/2"	right
SE14204L	3/8"	3"	4-1/2"	left
SE14204R	3/8"	3"	4-1/2"	right
SE14205L	25/64"	3"	4-1/2"	left
SE14205R	25/64"	3"	4-1/2"	right
SE14206L	7/16"	3"	4-1/2"	left
SE14206R	7/16"	3"	4-1/2"	right
SE14207L	1/2"	3"	4-1/2"	left
SE14207R	1/2"	3"	4-1/2"	right
SE142071L	33/64"	3"	4-1/2"	left
SE142071R	33/64"	3"	4-1/2"	right
SE14208L	5/8"	3"	4-1/2"	left
SE14208R	5/8"	3"	4-1/2"	right
SE14209L	3/4"	3"	4-1/2"	left
SE14209R	3/4"	3"	4-1/2"	right
SE142098L	7/8"	3"	4-1/2"	left
SE142098R	7/8"	3"	4-1/2"	right
SE14210L	1"	3"	4-1/2"	left
SE14210R	1"	3"	4-1/2"	right

Other sizes available.

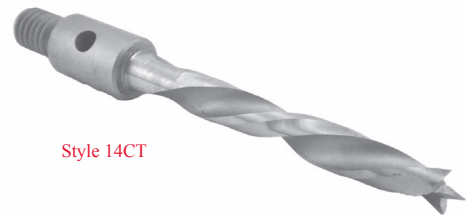

Style 14CT

Drills

METRIC CARBIDE-TIPPED THREADED-SHANK BRAD-POINT DRILLS, STYLE NO. 14CT

Recommended for use in any wood product containing glue, or long production runs in hardwood. Performs well in many plastics, as well as in several composite materials, including fiberglass.

Threaded shank is 7/16"-14.

Part Number	Cutting Diameter	Cutting Length	Overall Length	Rotational Direction
SE14200L	6mm	3"	4-1/2"	left
SE14200R	6mm	3"	4-1/2"	right
SE142031L	8mm	3"	4-1/2"	left
SE142031R	8mm	3"	4-1/2"	right
SE142051L	10mm	3"	4-1/2"	left
SE142051R	10mm	3"	4-1/2"	right
SE142064L	12mm	3"	4-1/2"	left
SE142064R	12mm	3"	4-1/2"	right
SE1420703L	13mm	3"	4-1/2"	left
SE1420703R	13mm	3"	4-1/2"	right

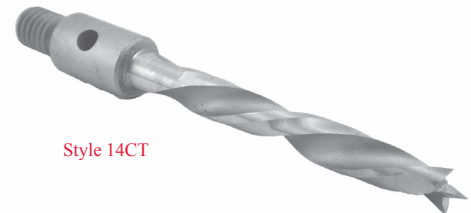

Style 14CT

CARBIDE-TIPPED THREADED-SHANK (EXTENDED) BRAD-POINT DRILLS, STYLE NO. 14ESCT

Recommended for use in any wood product containing glue, or long production runs in hardwood. Performs well in many plastics, as well as in several composite materials, including fiberglass.

Threaded shank is 7/16"-14.

Part Number	Cutting Diameter	Cutting Length	Overall Length	Rotational Direction
SE14217L	1/4"	1-7/8"	4-1/2"	left
SE14217R	1/4"	1-7/8"	4-1/2"	right
SE14218L	5/16"	1-7/8"	4-1/2"	left
SE14218R	5/16"	1-7/8"	4-1/2"	right
SE14219L	3/8"	1-7/8"	4-1/2"	left
SE14219R	3/8"	1-7/8"	4-1/2"	right
SE14221L	7/16"	1-7/8"	4-1/2"	left
SE14221R	7/16"	1-7/8"	4-1/2"	right
SE14222L	1/2"	1-7/8"	4-1/2"	left
SE14222R	1/2"	1-7/8"	4-1/2"	right

Other sizes available.



Style 14ESCT

THREADED-SHANK (EXTENDED) BRAD-POINT DRILLS, STYLE NO. 14ESHS

Threaded shank is 7/16"-14.

Made from high-speed steel.

Part Number	Cutting Diameter	Cutting Length	Overall Length	Rotational Direction
SE14135L	1/4"	1-1/2"	4-1/8"	left
SE14135R	1/4"	1-1/2"	4-1/8"	right
SE14136L	5/16"	1-1/2"	4-1/8"	left
SE14136R	5/16"	1-1/2"	4-1/8"	right
SE14137L	3/8"	1-1/2"	4-1/8"	left
SE14137R	3/8"	1-1/2"	4-1/8"	right
SE14138L	25/64"	1-1/2"	4-1/8"	left
SE14138R	25/64"	1-1/2"	4-1/8"	right
SE14139L	7/16"	1-1/2"	4-1/8"	left
SE14139R	7/16"	1-1/2"	4-1/8"	right
SE14140L	1/2"	1-1/2"	4-1/8"	left
SE14140R	1/2"	1-1/2"	4-1/8"	right

Other sizes available.



Style 14ESHS

1

2

3

4

5

6

7

8

9

10

Drills

THREADED-SHANK (EXTENDED) BRAD-POINT DRILLS, STYLE NO. 14ESHS-L

Threaded shank is 7/16"-14.

Made from high-speed steel.

Part Number	Cutting Diameter	Cutting Length	Overall Length	Rotational Direction
SE1414001L	1/8"	1-7/8"	4-1/2"	left
SE1414001R	1/8"	1-7/8"	4-1/2"	right
SE1414002L	5/32"	1-7/8"	4-1/2"	left
SE1414002R	5/32"	1-7/8"	4-1/2"	right
SE1414003L	3/16"	1-7/8"	4-1/2"	left
SE1414003R	3/16"	1-7/8"	4-1/2"	right
SE1414006L	7/32"	1-7/8"	4-1/2"	left
SE1414006R	7/32"	1-7/8"	4-1/2"	right
SE14141L	1/4"	1-7/8"	4-1/2"	left
SE14141R	1/4"	1-7/8"	4-1/2"	right
SE141411L	17/64"	1-7/8"	4-1/2"	left
SE141411R	17/64"	1-7/8"	4-1/2"	right
SE141412L	9/32"	1-7/8"	4-1/2"	left
SE141412R	9/32"	1-7/8"	4-1/2"	right
SE14142L	5/16"	1-7/8"	4-1/2"	left
SE14142R	5/16"	1-7/8"	4-1/2"	right
SE14143L	3/8"	1-7/8"	4-1/2"	left
SE14143R	3/8"	1-7/8"	4-1/2"	right
SE14144L	25/64"	1-7/8"	4-1/2"	left
SE14144R	25/64"	1-7/8"	4-1/2"	right
SE141450L	13/32"	1-7/8"	4-1/2"	left
SE141450R	13/32"	1-7/8"	4-1/2"	right
SE14145L	7/16"	1-7/8"	4-1/2"	left
SE14145R	7/16"	1-7/8"	4-1/2"	right
SE141451L	29/64"	1-7/8"	4-1/2"	left
SE141451R	29/64"	1-7/8"	4-1/2"	right
SE14146L	1/2"	1-7/8"	4-1/2"	left
SE14146R	1/2"	1-7/8"	4-1/2"	right
SE141401L	33/64"	1-7/8"	4-1/2"	left
SE141401R	33/64"	1-7/8"	4-1/2"	right

Other sizes available.



14ESHS-L

THREADED-SHANK BRAD-POINT DRILLS, STYLE NO. 14HS

Threaded shank is 7/16"-14.

Made from high-speed steel.

Part Number	Cutting Diameter	Cutting Length	Overall Length	Rotational Direction
SE141000L	1/8"	3"	4-1/2"	left
SE141000R	1/8"	3"	4-1/2"	right
SE141001L	9/64"	3"	4-1/2"	left
SE141001R	9/64"	3"	4-1/2"	right
SE141002L	5/32"	3"	4-1/2"	left
SE141002R	5/32"	3"	4-1/2"	right
SE14101L	3/16"	3"	4-1/2"	left
SE14101R	3/16"	3"	4-1/2"	right
SE14103L	1/4"	3"	4-1/2"	left
SE14103R	1/4"	3"	4-1/2"	right
SE14104L	9/32"	3"	4-1/2"	left
SE14104R	9/32"	3"	4-1/2"	right
SE14105L	5/16"	3"	4-1/2"	left
SE14105R	5/16"	3"	4-1/2"	right

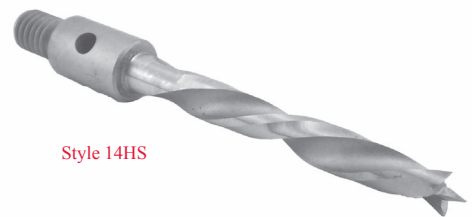

Style 14HS

- CONTINUED ON NEXT PAGE

Drills

THREADED-SHANK BRAD-POINT DRILLS, STYLE NO. 14HS – CONTINUED

Threaded shank is 7/16"-14.

Made from high-speed steel.

Part Number	Cutting Diameter	Cutting Length	Overall Length	Rotational Direction
SE141052L	21/64"	3"	4-1/2"	left
SE141052R	21/64"	3"	4-1/2"	right
SE14106L	11/32"	3"	4-1/2"	left
SE14106R	11/32"	3"	4-1/2"	right
SE14107L	3/8"	3"	4-1/2"	left
SE14107R	3/8"	3"	4-1/2"	right
SE14108L	25/64"	3"	4-1/2"	left
SE14108R	25/64"	3"	4-1/2"	right
SE14109L	7/16"	3"	4-1/2"	left
SE14109R	7/16"	3"	4-1/2"	right
SE14110L	29/64"	3"	4-1/2"	left
SE14110R	29/64"	3"	4-1/2"	right
SE14111L	1/2"	3"	4-1/2"	left
SE14111R	1/2"	3"	4-1/2"	right
SE141111L	33/64"	3"	4-1/2"	left
SE141111R	33/64"	3"	4-1/2"	right
SE14112L	9/16"	3"	4-1/2"	left
SE14112R	9/16"	3"	4-1/2"	right
SE14113L	5/8"	3"	4-1/2"	left
SE14113R	5/8"	3"	4-1/2"	right
SE141131L	11/16"	3"	4-1/2"	left
SE141131R	11/16"	3"	4-1/2"	right
SE14114L	3/4"	3"	4-1/2"	left
SE14114R	3/4"	3"	4-1/2"	right
SE141141L	13/16"	3"	4-1/2"	left
SE141141R	13/16"	3"	4-1/2"	right
SE14115L	7/8"	3"	4-1/2"	left
SE14115R	7/8"	3"	4-1/2"	right
SE14116L	1"	3"	4-1/2"	left
SE14116R	1"	3"	4-1/2"	right

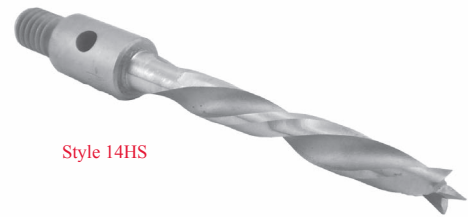

Style 14HS

THREADED-SHANK BRAD-POINT DRILLS, STYLE NO. 14HS METRIC

Threaded shank is 7/16"-14.

Made from high-speed steel.

Part Number	Cutting Diameter	Cutting Length	Overall Length	Rotational Direction
SE1410101L	5mm	3"	4-1/2"	left
SE1410101R	5mm	3"	4-1/2"	right
SE141022L	6mm	3"	4-1/2"	left
SE141022R	6mm	3"	4-1/2"	right
SE141053L	8mm	3"	4-1/2"	left
SE141053R	8mm	3"	4-1/2"	right
SE1410800L	10mm	3"	4-1/2"	left
SE1410800R	10mm	3"	4-1/2"	right
SE1411021L	12mm	3"	4-1/2"	left
SE1411021R	12mm	3"	4-1/2"	right
SE1411104L	13mm	3"	4-1/2"	left
SE1411104R	13mm	3"	4-1/2"	right

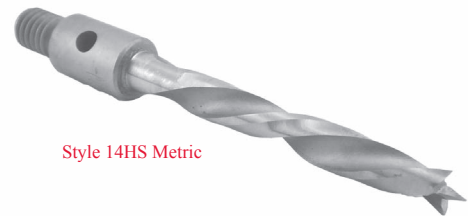

Style 14HS Metric

1

2

3

4

5

6

7

8

9

10

Drills

THREADED-SHANK BRAD-POINT DRILLS, STYLE NO. 14HSL

Threaded shank is 7/16"-14.

Made from high-speed steel.

Part Number	Cutting Diameter	Cutting Length	Overall Length
SE141073R	3/8"	5"	6-1/2"
SE1410931	7/16"	5"	6-1/2"
SE141109R	1/2"	5"	6-1/2"

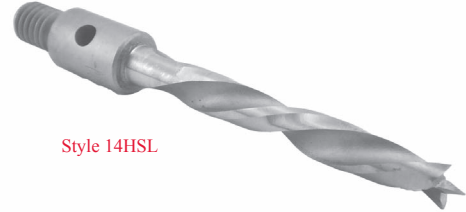

Style 14HSL

THREADED-SHANK BRAD-POINT DRILLS, STYLE NO. 14R

Threaded shank is 7/16"-14.

Made from high-speed steel.

Part Number	Cutting Diameter	Cutting Length	Overall Length	Rotational Direction
SE14147L	1/4"	1-5/8"	2-1/2"	left
SE14147R	1/4"	1-5/8"	2-1/2"	right
SE14148L	9/32"	1-5/8"	2-1/2"	left
SE14148R	9/32"	1-5/8"	2-1/2"	right
SE14149L	5/16"	1-5/8"	2-1/2"	left
SE14149R	5/16"	1-5/8"	2-1/2"	right
SE14151L	3/8"	1-5/8"	2-1/2"	left
SE14151R	3/8"	1-5/8"	2-1/2"	right
SE14152L	25/64"	1-5/8"	2-1/2"	left
SE14152R	25/64"	1-5/8"	2-1/2"	right
SE14153L	7/16"	1-5/8"	2-1/2"	left
SE14153R	7/16"	1-5/8"	2-1/2"	right
SE14154L	1/2"	1-5/8"	2-1/2"	left
SE14154R	1/2"	1-5/8"	2-1/2"	right
SE14155L	9/16"	1-5/8"	2-1/2"	left
SE14155R	9/16"	1-5/8"	2-1/2"	right
SE14156L	5/8"	1-5/8"	2-1/2"	left
SE14156R	5/8"	1-5/8"	2-1/2"	right



Style 14R

Other sizes available, call for pricing.

Drills

BRAD-POINT DRILL, STYLE NO. 19

Right-hand rotation.

Made from carbon steel.

	Part Number	Cutting Diameter	Cutting Length	Shank Diameter	Overall Length
NEW	SE19001	1/8"	3"	1/2"	5"
NEW	SE19002	5/32"	3"	1/2"	5"
	SE19003	3/16"	3"	1/2"	5"
	SE19004	7/32"	3"	1/2"	5"
	SE19005	1/4"	3"	1/2"	5"
	SE19009	5/16"	3"	1/2"	5"
	SE19012	3/8"	3"	1/2"	5"
	SE19015	7/16"	3"	1/2"	5"
NEW	SE19016	29/64"	3"	1/2"	5"
	SE19018	1/2"	3"	1/2"	5"
	SE19022	5/8"	3"	1/2"	5"
	SE19025	3/4"	3"	1/2"	5"
	SE19027	7/8"	3"	1/2"	5"
	SE19028	1"	3"	1/2"	5"
	SE19029	1-1/8"	3"	1/2"	5"
	SE19030	1-1/4"	3"	1/2"	5"



Style 19

CARBIDE-TIPPED BRAD POINT DRILL, STYLE NO. 19CT

Recommended for use in any wood product containing glue, or long production runs in hardwood. Performs well in many plastics, as well as in several composite materials, including fiberglass.

Right-hand rotation.

	Part Number	Cutting Diameter	Cutting Length	Shank Diameter	Overall Length
	SE19201	1/4"	3"	1/2"	5"
	SE19202	9/32"	3"	1/2"	5"
	SE19203	5/16"	3"	1/2"	5"
	SE19204	3/8"	3"	1/2"	5"
	SE19206	7/16"	3"	1/2"	5"
	SE19207	1/2"	3"	1/2"	5"
	SE19208	5/8"	3"	1/2"	5"
NEW	SE192084	11/16"	3"	1/2"	5"
	SE19209	3/4"	3"	1/2"	5"
	SE192091	7/8"	3"	1/2"	5"
	SE1920914	15/16"	3"	1/2"	5"
	SE19210	1"	3"	1/2"	5"

Other sizes available, call for pricing.

CARBIDE-TIPPED BRAD POINT DRILL, STYLE NO. 19CT METRIC

Recommended for use in any wood product containing glue, or long production runs in hardwood. Performs well in many plastics, as well as in several composite materials, including fiberglass.

Right-hand rotation.

	Part Number	Cutting Diameter	Cutting Length	Shank Diameter	Overall Length
	SE1920301	8mm	3"	1/2"	5"
	SE192051	10mm	3"	1/2"	5"
	SE192064	12mm	3"	1/2"	5"
	SE1920713	13mm	3"	1/2"	5"

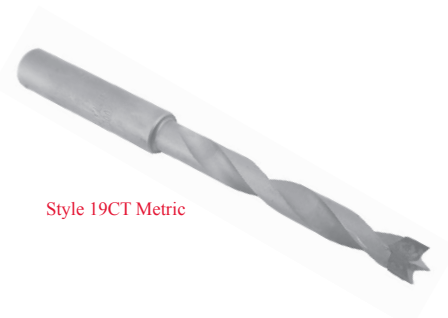

Style 19CT Metric

1

2

3

4

5

6

7

8

9

10

Drills

BRAD-POINT DRILL, STYLE NO. 19HS

Right-hand rotation.

Made from high-speed steel.

Part Number	Cutting Diameter	Cutting Length	Overall Length	Shank Diameter
SE19100	1/8"	3"	5"	1/2"
SE191002	5/32"	3"	5"	1/2"
SE19101	3/16"	3"	5"	1/2"
SE19102	7/32"	3"	5"	1/2"
SE19103	1/4"	3"	5"	1/2"
SE19104	9/32"	3"	5"	1/2"
SE191041	19/64"	3"	5"	1/2"
SE19105	5/16"	3"	5"	1/2"
SE191051	21/64"	3"	5"	1/2"
SE19106	11/32"	3"	5"	1/2"
SE19107	3/8"	3"	5"	1/2"
SE19108	25/64"	3"	5"	1/2"
SE19109	13/32"	3"	5"	1/2"
SE19110	7/16"	3"	5"	1/2"
SE19111	15/32"	3"	5"	1/2"
SE19112	1/2"	3"	5"	1/2"
SE191121	33/64"	3"	5"	1/2"
SE191122	17/32"	3"	5"	1/2"
SE19113	9/16"	3"	5"	1/2"
SE19114	5/8"	3"	5"	1/2"
NEW SE1911441	11/16"	3"	5"	1/2"
SE19115	3/4"	3"	5"	1/2"
SE191154	13/16"	3"	5"	1/2"
SE191158	7/8"	3"	5"	1/2"
NEW SE191159	15/16"	3"	5"	1/2"
SE19116	1"	3"	5"	1/2"
SE191160	1-1/8"	3"	5"	1/2"
SE191161	1-1/4"	3"	5"	1/2"

Other sizes available, call for pricing.

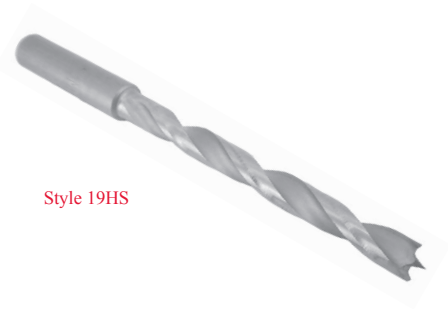

Style 19HS

BRAD-POINT DRILL, STYLE NO. 19HS METRIC

Right-hand rotation.

Made from high-speed steel.

Part Number	Cutting Diameter	Cutting Length	Overall Length	Shank Diameter
SE191010	5mm	3"	5"	1/2"
SE191020	6mm	3"	5"	1/2"
SE191030	7mm	3"	5"	1/2"
NEW SE191050	8mm	3"	5"	1/2"
SE191060	9mm	3"	5"	1/2"
SE191080	10mm	3"	5"	1/2"
SE1911101	12mm	3"	5"	1/2"
SE191130	15mm	3"	5"	1/2"

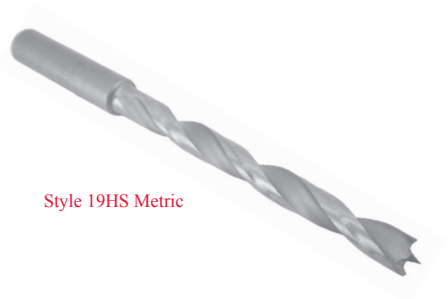

Style 19HS Metric

Drills

BRAD-POINT DRILL, STYLE NO. 19HSL

Left-hand rotation.

Made from high-speed steel.

Part Number	Cutting Diameter	Shank Diameter	Cutting Length	Overall Length
SE19101L	3/16"	1/2"	3"	5"
SE19103L	1/4"	1/2"	3"	5"
SE19105L	5/16"	1/2"	3"	5"
SE19107L	3/8"	1/2"	3"	5"
SE19110L	7/16"	1/2"	3"	5"
SE19112L	1/2"	1/2"	3"	5"

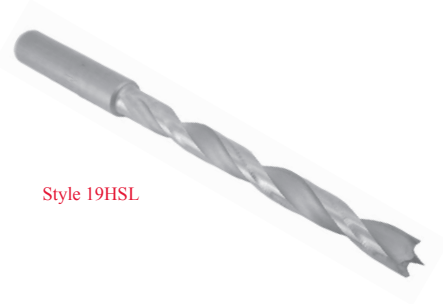

Style 19HSL

TAPERED BRUSH-BLOCK DRILL, STYLE NO. 19TP

Designed for boring brush-blocks.

Bores right-hand with a left-hand twist to reduce chatter.

High-speed steel 1/2" x 2" shank.

Part Number	Larger Taper Diameter	Small Taper Diameter	Flute Length	Overall Length
SE19995	1-1/8"	11/16"	3"	5"

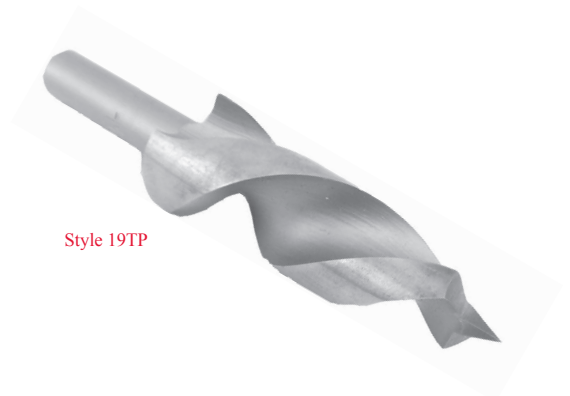

Style 19TP

BRAD-POINT DRILL, STYLE NO. 20

Right-hand rotation.

Made from carbon tool steel.

Part Number	Cutting Diameter	Cutting Length	Shank Diameter	Overall Length
NEW SE20002	5/23"	4"	1/2"	6"
SE20003	3/16"	4"	1/2"	6"
SE20006	1/4"	4"	1/2"	6"
NEW SE20007	17/64"	4"	1/2"	6"
SE20010	5/16"	4"	1/2"	6"
SE20013	3/8"	4"	1/2"	6"
SE20016	7/16"	4"	1/2"	6"
SE20019	1/2"	4"	1/2"	6"
NEW SE20021	17/32"	4"	1/2"	6"
SE20022	9/16"	4"	1/2"	6"
SE20024	5/8"	4"	1/2"	6"
NEW SE20025	21/32"	4"	1/2"	6"
NEW SE20026	11/16"	4"	1/2"	6"
SE20028	3/4"	4"	1/2"	6"
SE20032	7/8"	4"	1/2"	6"
SE20036	1"	4"	1/2"	6"
NEW SE20037	1-1/32"	4"	1/2"	6"
NEW SE20038	1-1/16"	4"	1/2"	6"
SE20039	1-1/8"	4"	1/2"	6"
NEW SE20040	1-1/8"	4"	1/2"	6"
SE20041	1-1/4"	4"	1/2"	6"
SE20042	1-5/16"	4"	1/2"	6"
SE20043	1-3/8"	4"	1/2"	6"
SE20044	1-1/2"	4"	1/2"	6"

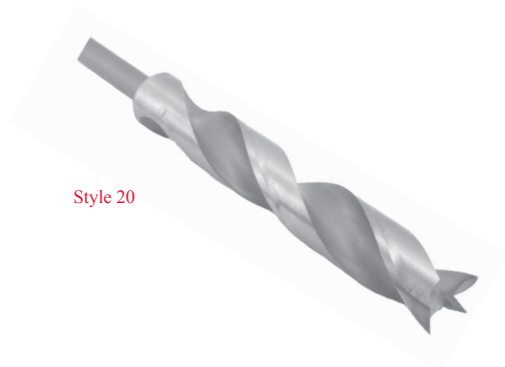

Style 20

Other sizes available, call for pricing.

1

2

3

4

5

6

7

8

9

10

Drills

BRAD-POINT DRILL, STYLE NO. 20BHS

Made from high-speed steel.

Shank length 1 1/2".

Right-hand rotation.

Part Number	Cutting Diameter	Cutting Length	Overall Length	Shank Diameter
SE20305HS	7/32"	4"	5-1/2"	3/8"
SE203050HS	1/4"	4"	5-1/2"	3/8"
SE203051HS	9/32"	4"	5-1/2"	3/8"
SE203052HS	5/16"	4"	5-1/2"	3/8"
SE203053HS	11/32"	4"	5-1/2"	3/8"
SE20307HS	3/8"	4"	5-1/2"	3/8"
SE203081HS	10mm	4"	5-1/2"	3/8"
SE20308HS	25/64"	4"	5-1/2"	3/8"
SE20309HS	13/32"	4"	5-1/2"	3/8"
SE20310HS	7/16"	4"	5-1/2"	3/8"
SE20311HS	15/32"	4"	5-1/2"	3/8"
SE20312HS	1/2"	4"	5-1/2"	3/8"
SE203122HS	13mm	4"	5-1/2"	3/8"
SE20313HS	17/32"	4"	5-1/2"	3/8"
SE20314HS	9/16"	4"	5-1/2"	3/8"
SE20315HS	5/8"	4"	5-1/2"	3/8"
SE20316HS	11/16"	4"	5-1/2"	3/8"
SE20317HS	3/4"	4"	5-1/2"	3/8"
SE20318HS	13/16"	4"	5-1/2"	3/8"
SE20319HS	7/8"	4"	5-1/2"	3/8"
SE20320HS	15/16"	4"	5-1/2"	3/8"
SE20321HS	1"	4"	5-1/2"	3/8"

Other sizes available, call for pricing.

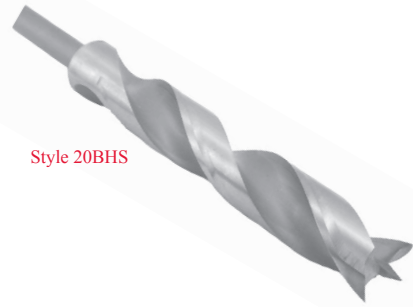

Style 20BHS

CARBIDE-TIPPED BRAD-POINT DRILL, STYLE NO. 20BCT

Recommended for use in any wood product containing glue, or long production runs in hardwood. Performs well in many plastics, as well as in several composite materials, including fiberglass.

Right-hand rotation.

Part Number	Cutting Diameter	Cutting Length	Shank Diameter	Overall Length
SE20307CT	3/8"	4"	3/8"	5-1/2"
SE20308CT	25/64"	4"	3/8"	5-1/2"
SE20310CT	7/16"	4"	3/8"	5-1/2"
SE20312CT	1/2"	4"	3/8"	5-1/2"
SE20314CT	9/16"	4"	3/8"	5-1/2"
SE20315CT	5/8"	4"	3/8"	5-1/2"
SE20317CT	3/4"	4"	3/8"	5-1/2"

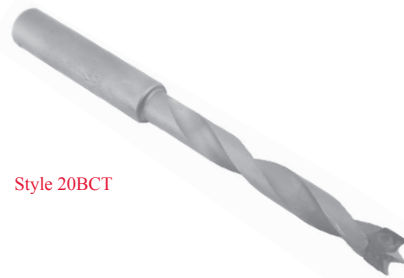

Style 20BCT

Drills

CARBIDE-TIPPED BRAD-POINT DRILL, STYLE NO. 20CT

Recommended for use in any wood product containing glue, or long production runs in hardwood. Performs well in many plastics, as well as in several composite materials, including fiberglass.

Right-hand rotation.

Part Number	Cutting Diameter	Flute Length	Shank Dimensions	Overall Length
SE20701	1/4"	4"	1/2" x 2"	6"
SE20703	5/16"	4"	1/2" x 2"	6"
SE20704	3/8"	4"	1/2" x 2"	6"
SE20706	7/16"	4"	1/2" x 2"	6"
SE20707	1/2"	4"	1/2" x 2"	6"
SE20708	5/8"	4"	1/2" x 2"	6"
SE20709	3/4"	4"	1/2" x 2"	6"
SE207098	7/8"	4"	1/2" x 2"	6"
SE20710	1"	4"	1/2" x 2"	6"
SE070912	15-16"	4"	1/2" x 2"	6"



BRAD-POINT DRILL, STYLE NO. 20HS

Right-hand rotation.

Made from high-speed steel.

Part Number	Cutting Diameter	Cutting Length	Shank Diameter	Overall Length
SE20100	1/8"	4"	1/2"	6"
SE201002	5/32"	4"	1/2"	6"
SE20101	3/16"	4"	1/2"	6"
SE201011	13/64"	4"	1/2"	6"
SE20102	7/32"	4"	1/2"	6"
SE20103	1/4"	4"	1/2"	6"
SE201031	17/64"	4"	1/2"	6"
SE20104	9/32"	4"	1/2"	6"
SE20105	5/16"	4"	1/2"	6"
SE201050	21/64"	4"	1/2"	6"
SE20106	11/32"	4"	1/2"	6"
SE20107	3/8"	4"	1/2"	6"
SE20108	25/64"	4"	1/2"	6"
SE20109	13/32"	4"	1/2"	6"
SE20110	7/16"	4"	1/2"	6"
SE201101	29/64"	4"	1/2"	6"
SE20111	15/32"	4"	1/2"	6"
SE20112	1/2"	4"	1/2"	6"
SE201121	33/64"	4"	1/2"	6"
SE20113	17/32"	4"	1/2"	6"
SE20114	9/16"	4"	1/2"	6"
SE201142	19/32"	4"	1/2"	6"
SE20115	5/8"	4"	1/2"	6"
SE201152	21/32"	4"	1/2"	6"
SE20116	11/16"	4"	1/2"	6"
SE201162	23/32"	4"	1/2"	6"
SE20117	3/4"	4"	1/2"	6"
SE201172	25/32"	4"	1/2"	6"
SE20118	13/16"	4"	1/2"	6"
SE201183	27/32"	4"	1/2"	6"
SE20119	7/8"	4"	1/2"	6"
SE201192	29/32"	4"	1/2"	6"
SE20120	15/16"	4"	1/2"	6"
SE201202	31/32"	4"	1/2"	6"



Style 20CT



Style 20HS

1

2

3

4

5

6

7

8

9

10

Drills

BRAD-POINT DRILL, STYLE NO. 20HS

– CONTINUED

Right-hand rotation.

Made from high-speed steel.

Part Number	Cutting Diameter	Cutting Length	Shank Diameter	Overall Length
SE20121	1"	4"	1/2"	6"
SE201221	1 1/32"	4"	1/2"	6"
SE20122	1 1/16"	4"	1/2"	6"
SE20123	1 1/8"	4"	1/2"	6"
SE20124	1 1/4"	4"	1/2"	6"
SE20125	1 5/16"	4"	1/2"	6"
SE20126	1 3/8"	4"	1/2"	6"
SE20128	1 1/2"	4"	1/2"	6"

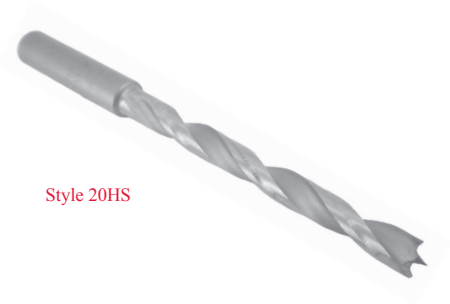

Style 20HS

BRAD-POINT DRILL, STYLE NO. 20HS

METRIC

Right-hand rotation.

Made from high-speed steel.

Part Number	Cutting Diameter	Cutting Length	Shank Diameter	Overall Length
SE201022	6mm	4"	1/2"	6"
SE201051	8mm	4"	1/2"	6"
SE201081	10mm	4"	1/2"	6"
SE201111	12mm	4"	1/2"	6"
SE201122	13mm	4"	1/2"	6"

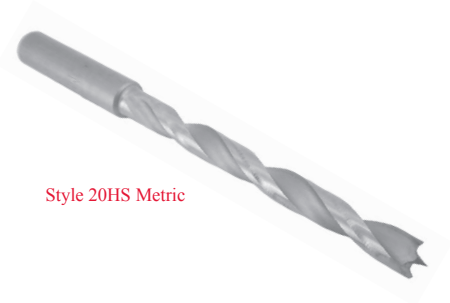

Style 20HS Metric

BRAD-POINT DRILL, STYLE NO. 20HSLH

Left-hand rotation.

Made from high-speed steel.

Part Number	Cutting Diameter	Cutting Length	Shank Diameter	Overall Length
SE20201HS	3/8"	4"	1/2"	6"
SE20202HS	7/16"	4"	1/2"	6"
SE20203HS	1/2"	4"	1/2"	6"



Style 20HSLH

Drills

CARBIDE-TIPPED BRAD-POINT DRILL, STYLE NO. 20-6CT

Recommended for use in any wood product containing glue, or long production runs in hardwood. Performs well in many plastics, as well as in several composite materials, including fiberglass.

Right-hand rotation.

Part Number	Cutting Diameter	Cutting Length	Shank Diameter	Overall Length
SE20601CT	1/4"	6"	1/2"	8"
SE20602CT	5/16"	6"	1/2"	8"
SE20604CT	3/8"	6"	1/2"	8"
SE20606CT	7/16"	6"	1/2"	8"
SE20607CT	1/2"	6"	1/2"	8"
SE20609CT	5/8"	6"	1/2"	8"
SE20611CT	3/4"	6"	1/2"	8"
SE20613CT	7/8"	6"	1/2"	8"
SE20615CT	1"	6"	1/2"	8"

Other sizes available, call for pricing.



BRAD-POINT DRILL, STYLE NO. 20-6

Right-hand rotation.

Made from carbon tool steel.

Part Number	Cutting Diameter	Overall Length	Cutting Length	Shank Diameter
SE20601	1/4"	8"	6"	1/2"
SE20602	5/16"	8"	6"	1/2"
SE20603	11/32"	8"	6"	1/2"
SE20604	3/8"	8"	6"	1/2"
SE20605	13/32"	8"	6"	1/2"
SE20606	7/16"	8"	6"	1/2"
SE20607	1/2"	8"	6"	1/2"
SE20608	9/16"	8"	6"	1/2"
SE20609	5/8"	8"	6"	1/2"
SE20610	11/16"	8"	6"	1/2"
SE20611	3/4"	8"	6"	1/2"
SE20612	13/16"	8"	6"	1/2"
SE20613	7/8"	8"	6"	1/2"
SE20614	15/16"	8"	6"	1/2"
SE20615	1"	8"	6"	1/2"
SE20616	1-1/16"	8"	6"	1/2"
SE20617	1-1/8"	8"	6"	1/2"
SE20618	1-1/4"	8"	6"	1/2"

Other sizes available, call for pricing.



1

2

3

4

5

6

7

8

9

10

Drills

BRAD-POINT DRILL, STYLE NO. 20-6HS

Right-hand rotation.

Made from high-speed steel.

Part Number	Cutting Diameter	Cutting Length	Shank Diameter	Overall Length
SE20601HS	1/4"	6"	1/2"	8"
SE20602HS	5/16"	6"	1/2"	8"
SE20604HS	3/8"	6"	1/2"	8"
SE20605HS	13/32"	6"	1/2"	8"
SE20606HS	7/16"	6"	1/2"	8"
SE20607HS	1/2"	6"	1/2"	8"
SE20608HS	9/16"	6"	1/2"	8"
SE20609HS	5/8"	6"	1/2"	8"
SE20610HS	11/16"	6"	1/2"	8"
SE20611HS	3/4"	6"	1/2"	8"
SE20612HS	13/16"	6"	1/2"	8"
SE20613HS	7/8"	6"	1/2"	8"
SE20614HS	15/16"	6"	1/2"	8"
SE20615HS	1"	6"	1/2"	8"
SE20616HS	1-1/16"	6"	1/2"	8"
SE20617HS	1-1/8"	6"	1/2"	8"
SE20618HS	1-1/4"	6"	1/2"	8"

Other sizes available, call for pricing.



Style 20-6HS

Custom Drills

Special sizes are not subject to return or cancellation, and are considered complete with 20% over or under quantity ordered.

The following information is needed to quote special drills:

1. Quantity _____
2. Cutting Diameter _____
3. Twist or Cutting Length _____
4. Shank Diameter & Length _____
5. Overall Length _____
6. Material (Carbide, High-Speed Steel or Carbon Steel) _____
7. Point Style (Brad, V-Point or other) _____
8. Rotation _____

Please sketch other point style,

FAX: 866-945-9433

Drills

GENERAL PURPOSE DRILL, JOBBER LENGTH, STYLE NO. 29 • 118° POINT

Right-hand rotation.

Made from high-speed steel.

Made in USA.

Part Number	Cutting Diameter	Overall Length	Flute Length	Shank Length
SE29001	1/64"	3/4"	3/16"	9/16"
SE29002	1/32"	1-3/8"	1/2"	7/8"
SE29003	3/64"	1-3/4"	3/4"	1"
SE29004	1/16"	1-7/8"	7/8"	1"
SE29005	5/64"	2"	1"	1"
SE29006	3/32"	2-1/4"	1-1/4"	1"
SE29007	7/64"	2-5/8"	1-1/2"	1-1/8"
SE29008	1/8"	2-3/4"	1-5/8"	1-1/8"
SE29009	9/64"	2-7/8"	1-3/4"	1-1/8"
SE29010	5/32"	3-1/8"	2"	1-1/8"
SE29011	11/64"	3-1/4"	2-1/8"	1-1/8"
SE29012	3/16"	3-1/2"	2-5/16"	1-3/16"
SE29013	13/64"	3-5/8"	2-7/16"	1-3/16"
SE29014	7/32"	3-3/4"	2-1/2"	1-1/4"
SE29015	15/64"	3-7/8"	2-5/8"	1-1/4"
SE29016	1/4"	4"	2-3/4"	1-1/4"
SE29017	17/64"	4-1/8"	2-7/8"	1-1/4"
SE29018	9/32"	4-1/4"	2-15/16"	1-5/16"
SE29019	19/64"	4-3/8"	3-1/16"	1-5/16"
SE29020	5/16"	4-1/2"	3-3/16"	1-5/16"
SE29021	21/64"	4-5/8"	3-5/16"	1-5/16"
SE29022	11/32"	4-3/4"	3-7/16"	1-5/16"
SE29023	23/64"	4-7/8"	3-1/2"	1-3/8"
SE29024	3/8"	5"	3-5/8"	1-3/8"
SE29025	25/64"	5-1/8"	3-3/4"	1-3/8"
SE29026	13/32"	5-1/4"	3-7/8"	1-3/8"
SE29027	27/64"	5-3/8"	3-15/16"	1-7/16"
SE29028	7/16"	5-1/2"	4-1/16"	1-7/16"
SE29029	29/64"	5-5/8"	4-3/16"	1-7/16"
SE29030	15/32"	5-3/4"	4-5/16"	1-7/16"
SE29031	31/64"	5-7/8"	4-3/8"	1-1/2"
SE29032	1/2"	6"	4-1/2"	1-1/2"



Style 29

GENERAL PURPOSE DRILL, JOBBER LENGTH, STYLE NO. 29LH • 118° POINT

Left-hand rotation.

Made from high-speed steel.

Made in USA.

Part Number	Cutting Diameter	Overall Length	Flute Length	Shank Length
SE29002L	1/32"	1-3/8"	1/2"	7/8"
SE29003L	3/64"	1-3/4"	3/4"	1"
SE29004L	1/16"	1-7/8"	7/8"	1"
SE29005L	5/64"	2"	1"	1"
SE29006L	3/32"	2-1/4"	1-1/4"	1"
SE29007L	7/64"	2-5/8"	1-1/2"	1-1/8"



Style 29LH

- CONTINUED ON NEXT PAGE

1

2

3

4

5

6

7

8

9

10

Drills

GENERAL PURPOSE DRILL, JOBBER LENGTH, STYLE NO. 29LH • 118° POINT – CONTINUED

Left-hand rotation.

Made from high-speed steel.

Made in USA.

Part Number	Cutting Diameter	Overall Length	Flute Length	Shank Length
SE29008L	1/8"	2-3/4"	1-5/8"	1-1/8"
SE29009L	9/64"	2-7/8"	1-3/4"	1-1/8"
SE29010L	5/32"	3-1/8"	2"	1-1/8"
SE29011L	11/64"	3-1/4"	2-1/8"	1-1/8"
SE29012L	3/16"	3-1/2"	2-5/16"	1-3/16"
SE29013L	13/64"	3-5/8"	2-7/16"	1-3/16"
SE29014L	7/32"	3-3/4"	2-1/2"	1-1/4"
SE29015L	15/64"	3-7/8"	2-5/8"	1-1/4"
SE29016L	1/4"	4"	2-3/4"	1-1/4"
SE29017L	17/64"	4-1/8"	2-7/8"	1-1/4"
SE29018L	9/32"	4-1/4"	2-15/16"	1-5/16"
SE29019L	19/64"	4-3/8"	3-1/16"	1-5/16"
SE29020L	5/16"	4-1/2"	3-3/16"	1-5/16"
SE29021L	21/64"	4-5/8"	3-5/16"	1-5/16"
SE29022L	11/32"	4-3/4"	3-7/16"	1-5/16"
SE29023L	23/64"	4-7/8"	3-1/2"	1-3/8"
SE29024L	3/8"	5"	3-5/8"	1-3/8"
SE29025L	25/64"	5-1/8"	3-3/4"	1-3/8"
SE29026L	13/32"	5-1/4"	3-7/8"	1-3/8"
SE29027L	27/64"	5-3/8"	3-15/16"	1-7/16"
SE29028L	7/16"	5-1/2"	4-1/16"	1-7/16"
SE29029L	29/64"	5-5/8"	4-3/16"	1-7/16"
SE29030L	15/32"	5-3/4"	4-5/16"	1-7/16"
SE29031L	31/64"	5-7/8"	4-3/8"	1-1/2"
SE29032L	1/2"	6"	4-1/2"	1-1/2"



Style 29LH

GENERAL PURPOSE DRILL, JOBBER LENGTH, METRIC. STYLE NO. 29M

Right-hand rotation.

Made from high-speed steel.

Made in USA.

Part Number	Cutting Diameter	Overall Length	Flute Length	Shank Length
SE295005	0.5mm	22mm	6mm	16mm
SE29501	1mm	34mm	12mm	22mm
SE295015	1.5mm	40mm	18mm	22mm
SE29502	2mm	49mm	24mm	25mm
SE295026	2.5mm	57mm	30mm	27mm
SE29503	3mm	61mm	33mm	28mm
SE295036	3.5mm	70mm	39mm	31mm
SE29504	4mm	75mm	43mm	32mm
SE295045	4.5mm	80mm	47mm	33mm
SE29505	5mm	86mm	52mm	34mm
SE295055	5.5mm	93mm	57mm	36mm
SE29506	6mm	93mm	57mm	36mm
SE295065	6.5mm	101mm	63mm	38mm
SE29507	7mm	109mm	69mm	40mm
SE295075	7.5mm	109mm	69mm	40mm
SE29508	8mm	117mm	75mm	42mm



Style 29M

– CONTINUED ON NEXT PAGE

Drills

GENERAL PURPOSE DRILL, JOBBER LENGTH, METRIC. STYLE NO. 29M – CONTINUED

Right-hand rotation.

Made from high-speed steel.

Made in USA.

Part Number	Cutting Diameter	Overall Length	Flute Length	Shank Length
SE295085	8.5mm	117mm	75mm	42mm
SE29509	9mm	125mm	81mm	44mm
SE295095	9.5mm	125mm	81mm	44mm
SE29510	10mm	133mm	87mm	46mm
SE295105	10.5mm	133mm	87mm	46mm
SE29511	11mm	142mm	94mm	48mm
SE295115	11.5mm	142mm	94mm	48mm
SE29512	12mm	151mm	101mm	50mm
SE295125	12.5mm	151mm	101mm	50mm
SE29513	13mm	151mm	101mm	50mm



Style 29M

GENERAL PURPOSE DRILL SETS, JOBBER LENGTH

Made from high-speed steel.

Made in USA.

Complete with folding metal case.

Fractional Sizes

Part Number	Drills Per Set	Size Range	Size Increments
SEJS13M	13	1/16" to 1/4"	by 64ths
SEJS15M	15	1/16" to 1/2"	by 32nds
SEJS21M	21	1/16" to 3/8"	by 64ths
SEJS29M	29	1/16" to 1/2"	by 64ths

Metric Sizes

Part Number	Drills Per Set	Size Range	Size Increments
SEJS25MET	25	1mm - 13mm	by 0.5mm
SEJS49MET	41	6mm - 10mm	by 0.1mm



Straight Shank Drill Set

1

2

3

4

5

6

7

8

9

10

Drills

GENERAL PURPOSE DRILL, SHORT LENGTH, STYLE NO. 29S

Made from high-speed steel.

Part Number	Cutting Diameter	Cutting Length	Overall Length	Shank Length
SE29101	1/8"	7/8"	1-7/8"	1"
SE29102	9/64"	15/16"	1-15/16"	1"
SE29103	5/32"	1"	2-1/16"	1-1/16"
SE29104	11/64"	1-1/16"	2-1/8"	1-1/16"
SE29105	3/16"	1-1/8"	2-3/16"	1-1/16"
SE29106	13/64"	1-3/16"	2-1/4"	1-1/16"
SE29107	7/32"	1-1/4"	2-3/8"	1-1/8"
SE29108	15/64"	1-5/16"	2-7/16"	1-1/8"
SE29109	1/4"	1-3/8"	2-1/2"	1-1/8"
SE29110	17/64"	1-7/16"	2-5/8"	1-3/16"
SE29111	9/32"	1-1/2"	2-11/16"	1-3/16"
SE29112	19/64"	1-9/16"	2-3/4"	1-3/16"
SE29113	5/16"	1-5/8"	2-13/16"	1-3/16"
SE29114	21/64"	1-11/16"	2-15/16"	1-1/4"
SE29115	11/32"	1-11/16"	3"	1-5/16"
SE29116	23/64"	1-3/4"	3-1/16"	1-5/16"
SE29117	3/8"	1-13/16"	3-1/8"	1-5/16"
SE29118	25/64"	1-7/8"	3-1/4"	1-3/8"
SE29119	13/32"	1-15/16"	3-5/16"	1-3/8"
SE29120	27/64"	2"	3-3/8"	1-3/8"
SE29121	7/16"	2-1/16"	3-7/16"	1-3/8"
SE29122	29/64"	2-1/8"	3-9/16"	1-7/16"
SE29123	15/32"	2-1/8"	3-5/8"	1-1/2"
SE29124	31/64"	2-3/16"	3-11/16"	1-1/2"
SE29125	1/2"	2-1/4"	3-3/4"	1-1/2"
SE29133	5/8"	2-3/4"	4-1/4"	1-1/2"



Style 29S

GENERAL PURPOSE DRILL, SHORT LENGTH, STYLE NO. 29SLH

Left-hand rotation.

Made from high-speed steel.

Part Number	Cutting Diameter	Cutting Length	Overall Length	Shank Length
SE29101L	1/8"	7/8"	1-7/8"	1"
SE29102L	9/64"	15/16"	1-15/16"	1"
SE29103L	5/32"	1"	2-1/16"	1-1/16"
SE29104L	11/64"	1-1/16"	2-1/8"	1-1/16"
SE29105L	3/16"	1-1/8"	2-3/16"	1-1/16"
SE29106L	13/64"	1-3/16"	2-1/4"	1-1/16"
SE29107L	7/32"	1-1/4"	2-3/8"	1-1/8"
SE29108L	15/64"	1-5/16"	2-7/16"	1-1/8"
SE29109L	1/4"	1-3/8"	2-1/2"	1-1/8"
SE29110L	17/64"	1-7/16"	2-5/8"	1-3/16"
SE29111L	9/32"	1-1/2"	2-11/16"	1-3/16"
SE29112L	19/64"	1-9/16"	2-3/4"	1-3/16"
SE29113L	5/16"	1-5/8"	2-13/16"	1-3/16"
SE29114L	21/64"	1-11/16"	2-15/16"	1-1/4"
SE29115L	11/32"	1-11/16"	3"	1-5/16"
SE29116L	23/64"	1-3/4"	3-1/16"	1-5/16"
SE29117L	3/8"	1-13/16"	3-1/8"	1-5/16"
SE29118L	25/64"	1-7/8"	3-1/4"	1-3/8"
SE29119L	13/32"	1-15/16"	3-5/16"	1-3/8"
SE29120L	27/64"	2"	3-3/8"	1-3/8"
SE29121L	7/16"	2-1/16"	3-7/16"	1-3/8"
SE29122L	29/64"	2-1/8"	3-9/16"	1-7/16"
SE29123L	15/32"	2-1/8"	3-5/8"	1-1/2"
SE29124L	31/64"	2-3/16"	3-11/16"	1-1/2"
SE29125L	1/2"	2-1/4"	3-3/4"	1-1/2"



Style 29SLH

Drills

GENERAL PURPOSE DRILL, LONG LENGTH, STYLE NO. 29T

Right-hand rotation. Made from high-speed steel. Made in USA.

Part Number	Cutting Diameter	Flute Length	Shank Length	Overall Length
SE29201	1/8"	2-3/4"	2-3/8"	5-1/8"
SE29202	9/64"	3"	2-3/8"	5-3/8"
SE29203	5/32"	3"	2-3/8"	5-3/8"
SE29204	11/64"	3-3/8"	2-3/8"	5-3/4"
SE29205	3/16"	3-3/8"	2-3/8"	5-3/4"
SE29206	13/64"	3-5/8"	2-3/8"	6"
SE29207	7/32"	3-5/8"	2-3/8"	6"
SE29208	15/64"	3-3/4"	2-3/8"	6-1/8"
SE29209	1/4"	3-3/4"	2-3/8"	6-1/8"
SE29210	17/64"	3-7/8"	2-3/8"	6-1/4"
SE29211	9/32"	3-7/8"	2-3/8"	6-1/4"
SE29212	19/64"	4"	2-3/8"	6-3/8"
SE29213	5/16"	4"	2-3/8"	6-3/8"
SE29214	21/64"	4-1/8"	2-3/8"	6-1/2"
SE29215	11/32"	4-1/8"	2-3/8"	6-1/2"
SE29216	23/64"	4-1/4"	2-1/2"	6-3/4"
SE29217	3/8"	4-1/4"	2-1/2"	6-3/4"
SE29218	25/64"	4-3/8"	2-5/8"	7"
SE29219	13/32"	4-3/8"	2-5/8"	7"
SE29220	27/64"	4-5/8"	2-5/8"	7-1/4"
SE29221	7/16"	4-5/8"	2-5/8"	7-1/4"
SE29222	29/64"	4-3/4"	2-3/4"	7-1/2"
SE29223	15/32"	4-3/4"	2-3/4"	7-1/2"
SE29224	31/64"	4-3/4"	3"	7-3/4"
SE29225	1/2"	4-3/4"	3"	7-3/4"



Style 29T

GENERAL PURPOSE DRILL, LONG LENGTH, FAST SPIRAL, STYLE NO. 29TF

Right-hand rotation. Made from high-speed steel. Made in USA.

Part Number	Cutting Diameter	Flute Length	Shank Length	Overall Length
SE29201F	1/8"	2-3/4"	2-3/8"	5-1/8"
SE29202F	9/64"	3"	2-3/8"	5-3/8"
SE29203F	5/32"	3"	2-3/8"	5-3/8"
SE29204F	11/64"	3-3/8"	2-3/8"	5-3/4"
SE29205F	3/16"	3-3/8"	2-3/8"	5-3/4"
SE29206F	13/64"	3-5/8"	2-3/8"	6"
SE29207F	7/32"	3-5/8"	2-3/8"	6"
SE29208F	15/64"	3-3/4"	2-3/8"	6-1/8"
SE29209F	1/4"	3-3/4"	2-3/8"	6-1/8"
SE29210F	17/64"	3-7/8"	2-3/8"	6-1/4"
SE29211F	9/32"	3-7/8"	2-3/8"	6-1/4"
SE29212F	19/64"	4"	2-3/8"	6-3/8"
SE29213F	5/16"	4"	2-3/8"	6-3/8"
SE29214F	21/64"	4-1/8"	2-3/8"	6-1/2"
SE29215F	11/32"	4-1/8"	2-3/8"	6-1/2"
SE29216F	23/64"	4-1/4"	2-1/2"	6-3/4"
SE29217F	3/8"	4-1/4"	2-1/2"	6-3/4"
SE29218F	25/64"	4-3/8"	2-5/8"	7"
SE29219F	13/32"	4-3/8"	2-5/8"	7"
SE29220F	27/64"	4-5/8"	2-5/8"	7-1/4"
SE29221F	7/16"	4-5/8"	2-5/8"	7-1/4"
SE29222F	29/64"	4-3/4"	2-3/4"	7-1/2"
SE29223F	15/32"	4-3/4"	2-3/4"	7-1/2"
SE29224F	31/64"	4-3/4"	3"	7-3/4"
SE29225F	1/2"	4-3/4"	3"	7-3/4"



Style 29TF

1

2

3

4

5

6

7

8

9

10

Drills

TAPER-POINT DRILL, JOBBER LENGTH, STYLE NO. 29JTP

Designed for use with wood screws.

Made from high-speed steel. Made in USA.

Part Number	Cutting Diameter	Flute Length	Screw Size	Overall Length
SE30078	5/64"	1"	2	2"
SE30093	3/32"	1-1/4"	3	2-1/4"
SE30109	7/64"	1-1/2"	4	2-5/8"
SE30125	1/8"	1-5/8"	5	2-3/4"
SE30140	9/64"	1-3/4"	6	2-7/8"
SE30156	5/32"	2"	7	3-1/8"
SE30171	11/64"	2"	8	3-1/4"
SE30187	3/16"	2-5/16"	9	3-1/2"
SE30203	13/64"	2-7/16"	10	3-5/8"
SE30218	7/32"	2-1/2"	12	3-3/4"
SE30234	15/64"	2-5/8"	14	3-7/8"
SE30250	1/4"	2-3/4"	14	4"
SE30265	17/64"	2-7/8"	16	4-1/8"
SE30281	9/32"	2-15/16"	16	4-1/4"
SE30296	19/64"	3-1/16"	18	4-3/8"
SE30312	5/16"	3-3/16"	18-20	4-1/2"
SE30328	21/64"	3-5/16"	20	4-5/8"
SE30343	11/32"	3-7/16"	20	4-3/4"
SE30359	23/64"	3-1/2"	24	4-7/8"
SE30375	3/8"	3-5/8"	24	5"



Style 29JTP

TAPER-POINT DRILL, TAPER LENGTH, STYLE NO. 29TTP

Designed for use with wood screws.

Made from high-speed steel. Made in USA.

Part Number	Cutting Diameter	Flute Length	Screw Size	Overall Length
SE31078	5/64"	2-1/4"	2	3-3/4"
SE31093	3/32"	2-1/4"	3	4-1/4"
SE31109	7/64"	2-1/2"	4	4-5/8"
SE31125	1/8"	2-3/4"	5	5-1/8"
SE31140	9/64"	3"	6	5-3/8"
SE31156	5/32"	3"	7	5-3/8"
SE31171	11/64"	3-3/8"	8	5-3/4"
SE31187	3/16"	3-3/8"	9	5-3/4"
SE31203	13/64"	3-5/8"	10	6"
SE31218	7/32"	3-5/8"	12	6"
SE31234	15/64"	3-3/4"	14	6-1/8"
SE31250	1/4"	3-3/4"	14	6-1/8"
SE31265	17/64"	3-7/8"	16	6-1/4"
SE31281	9/32"	3-7/8"	16	6-1/4"
SE31296	19/64"	4"	18	6-3/8"
SE31312	5/16"	4"	18-20	6-3/8"
SE31328	21/64"	4-1/8"	20	6-1/2"
SE31343	11/32"	4-1/8"	20	6-1/2"
SE31359	23/64"	4-1/4"	24	6-3/4"
SE31375	3/8"	4-1/4"	24	6-3/4"



Style 29TTP

Drills

DRILL-POINT 1/2" SHANK DRILL, SILVER & DEMING® • HIGH-SPEED STEEL

Designed for general purpose use.

Black-oxide surface treated.

Features a 118-degree point.

Part Number	Cutting Diameter	Cutting Length	Shank Diameter	Overall Length
SESD516	33/64"	3"	1/2"	6"
SESD531	17/32"	3"	1/2"	6"
SESD547	35/64"	3"	1/2"	6"
SESD563	9/16"	3"	1/2"	6"
SESD578	37/64"	3"	1/2"	6"
SESD594	19/32"	3"	1/2"	6"
SESD609	39/64"	3"	1/2"	6"
SESD625	5/8"	3"	1/2"	6"
SESD641	41/64"	3"	1/2"	6"
SESD656	21/32"	3"	1/2"	6"
SESD672	43/64"	3"	1/2"	6"
SESD688	11/16"	3"	1/2"	6"
SESD703	45/64"	3"	1/2"	6"
SESD719	23/32"	3"	1/2"	6"
SESD734	47/64"	3"	1/2"	6"
SESD750	3/4"	3"	1/2"	6"
SESD766	49/64"	3"	1/2"	6"
SESD781	25/32"	3"	1/2"	6"
SESD797	51/64"	3"	1/2"	6"
SESD813	13/16"	3"	1/2"	6"
SESD828	53/64"	3"	1/2"	6"
SESD844	27/32"	3"	1/2"	6"
SESD859	55/64"	3"	1/2"	6"
SESD875	7/8"	3"	1/2"	6"
SESD891	57/64"	3"	1/2"	6"
SESD906	29/32"	3"	1/2"	6"
SESD922	59/64"	3"	1/2"	6"
SESD938	15/16"	3"	1/2"	6"
SESD953	61/64"	3"	1/2"	6"
SESD969	31/32"	3"	1/2"	6"
SESD984	63/64"	3"	1/2"	6"
SESD1000	1"	3"	1/2"	6"



Silver & Deming® Drill

1

2

3

4

5

6

7

8

9

10

Drills

SOLID-CENTER MACHINE AUGER BITS, STYLE NO. 26A • CARBON TOOL STEEL

Designed for use in machines and power drills with chucks 1/2" or larger.

Single-flute design with double spurs and double cutters.

1/2" shank diameter.

Part Number	Cutting Diameter	Cutting Length	Shank Length	Overall Length
SE26115	5/16"	6"	2"	8"
SE26116	3/8"	6"	2"	8"
SE26117	7/16"	6"	2"	8"
SE26118	1/2"	6"	2"	8"
SE26119	9/16"	6"	2"	8"
SE26120	5/8"	6"	2"	8"
SE26121	11/16"	6"	2"	8"
SE26122	3/4"	6"	2"	8"
SE26123	13/16"	6"	2"	8"
SE26124	7/8"	6"	2"	8"
SE26126	1"	6"	2"	8"
SE26149	13/16"	10"	2"	12"
SE26155	3/8"	12"	2"	14"
SE26157	1/2"	12"	2"	14"
SE26159	5/8"	12"	2"	14"
SE26160	11/16"	12"	2"	14"
SE26161	3/4"	12"	2"	14"
SE26162	13/16"	12"	2"	14"
SE26163	7/8"	12"	2"	14"
SE26165	1"	12"	2"	14"



Style 26A Auger Bit

1

2

3

4

5

6

7

8

9

10

Drills

AUGER BITS, STYLE NO. 26F

Centerless ground, featuring a solid center design for added strength and a screw point for fast boring in all types of wood.

One flute, with single spur and single cutter.

Dual shank: hex portion may be removed from end when round shank is needed.

Carbon tool steel.

Made in France.

Part Number	Cutting Diameter	Overall Length	Corresponding Chuck Size
SEA250175	1/4"	7-1/2"	3/8" or larger
SEA250275	5/16"	7-1/2"	3/8" or larger
SEA250375	3/8"	7-1/2"	3/8" or larger
SEA250475	7/16"	7-1/2"	3/8" or larger
SEA250575	1/2"	7-1/2"	3/8" or larger
SEA250675	9/16"	7-1/2"	3/8" or larger
SEA250875	11/16"	7-1/2"	3/8" or larger
SEA251075	13/16"	7-1/2"	3/8" or larger
SEA251175	7/8"	7-1/2"	3/8" or larger
SEA251275	15/16"	7-1/2"	3/8" or larger
SEA251375	1"	7-1/2"	3/8" or larger
SEA251475	1-1/8"	7-1/2"	1/2" or larger
SEA251575	1-1/4"	7-1/2"	1/2" or larger
SEA251675	1-3/8"	7-1/2"	1/2" or larger
SEA251775	1-1/2"	7-1/2"	1/2" or larger
SEA250315	3/8"	15"	3/8" or larger
SEA250415	7/16"	15"	3/8" or larger
SEA250515	1/2"	15"	3/8" or larger
SEA250615	9/16"	15"	3/8" or larger
SEA250715	5/8"	15"	1/2" or larger
SEA250815	11/16"	15"	1/2" or larger
SEA250915	3/4"	15"	1/2" or larger
SEA251015	13/16"	15"	1/2" or larger
SEA251115	7/8"	15"	1/2" or larger
SEA251215	15/16"	15"	1/2" or larger
SEA251315	1"	15"	1/2" or larger
SEA251415	1-1/8"	15"	1/2" or larger
SEA251515	1-1/4"	15"	1/2" or larger
SEA251615	1-3/8"	15"	1/2" or larger
SEA251715	1-1/2"	15"	1/2" or larger



Style 26F Auger Bit

1

2

3

4

5

6

7

8

9

10

Drills

POWER POLE AUGER BIT STYLE 26PP • CARBON TOOL STEEL

Designed for boring creosoted poles and construction timbers.

Hex shank is 7/16" in diameter; fits all 1/2" 3-jaw chucks.

Part Number	Cutting Diameter	Flute Length	Shank Length	Overall Length
SE2646809	9/16"	12"	5"	17"
SE2646810	5/8"	12"	5"	17"
SE2646811	11/16"	12"	5"	17"
SE2646812	3/4"	12"	5"	17"
SE2646813	13/16"	12"	5"	17"
SE2646909	9/16"	18"	5"	23"
SE2646910	5/8"	18"	5"	23"
SE2646911	11/16"	18"	5"	23"
SE2646912	3/4"	18"	5"	23"
SE2646913	13/16"	18"	5"	23"
SE2646914	7/8"	18"	5"	23"
SE2646915	15/16"	18"	5"	23"
SE2647009	9/16"	24"	5"	29"
SE2647010	5/8"	24"	5"	29"
SE2647011	11/16"	24"	5"	29"
SE2647012	3/4"	24"	5"	29"
SE2647013	13/16"	24"	5"	29"
SE2647014	7/8"	24"	5"	29"
SE2647015	15/16"	24"	5"	29"
SE2647016	1"	24"	5"	29"
SE2647017	1-1/16"	24"	5"	29"



Style 26PP Auger Bit

DRILL-POINT DRILL, STYLE 32HS

Great for plastics!

Made from high-speed steel.

Part Number	Cutting Diameter	Cutting Length	Shank Diameter	Overall Length
SE32001HS	1/8"	4"	1/2"	6"
SE32003HS	3/16"	4"	1/2"	6"
SE32004HS	7/32"	4"	1/2"	6"
SE32005HS	1/4"	4"	1/2"	6"
SE32006HS	9/32"	4"	1/2"	6"
SE32007HS	5/16"	4"	1/2"	6"
SE32008HS	11/32"	4"	1/2"	6"
SE32009HS	3/8"	4"	1/2"	6"
SE32011HS	7/16"	4"	1/2"	6"
SE32012HS	1/2"	4"	1/2"	6"



Style 32HS

Drills

SELF CENTERING DRILL GUIDES (VIX BITS)

Designed to drill centered screw holes for cabinet and builders hardware.

Part Number	Drill Diameter	Screw Size	Shank Diameter	Overall Length
SE56401	5/64"	3 & 4	1/4"	3"
SE56401HX	5/64"	3 & 4	1/4" HEX	4"
SE76401	7/64"	5 & 6	1/4"	3-1/4"
SE76401HX	7/64"	5 & 6	1/4" HEX	4"
SE96401	9/64"	8, 9 & 10	1/4"	3-1/2"
SE96401HX	9/64"	8, 9 & 10	1/4" HEX	4"
SE116401	11/64"	12	3/8"	5"
SE116401HX	11/64"	12	1/4" HEX	4-1/2"
SE136401	13/64"	14	3/8"	4-1/2"
SE136401HX	13/64"	14	1/4" HEX	4-1/2"



VIX
Self-Centering
Drill Guides

REPLACEMENT DRILLS

Part Number	Drill Size	Replacement for stock numbers	Shank Diameter	Overall Length
SE56402	5/64"	SE56401, SE56401HX	5/64"	2-1/2"
SE76402	7/64"	SE76401, SE76401HX	7/64"	2-7/18"
SE96402	9/64"	SE96401, SE96401HX	9/64"	3-1/8"
SE116402	11/64"	SE116401, SE116401HX	11/64"	4-1/8"
SE136402	13/64"	SE136401, SE136401HX	13/64"	4-1/8"



SNAPPY
Hex Shaft
Self-Centering
Drill Guides

REPLACEMENT SPRINGS

Part Number	Spring Size	Replacement for stock numbers
SE56403	5/64"	SE56401, SE56401HX
SE76403	7/64"	SE76401, SE76401HX
SE96403	9/64"	SE96401, SE96401HX
SE116403	11/64"	SE116401, SE116401HX
SE136403	13/64"	SE136401, SE136401HX

REPLACEMENT GUIDES

Part Number	Guide Size	Replacement for stock numbers
SE56404	5/64"	SE56401, SE56401HX
SE76404	7/64"	SE76401, SE76401HX
SE96404	9/64"	SE96401, SE96401HX
SE116404	11/64"	SE116401, SE116401HX
SE136404	13/64"	SE136401, SE136401HX

1

2

3

4

5

6

7

8

9

10

Drills

DEPTH COLLARS & SETS

Designed for use with drills and counterbores.

Features collars with set screws which lock into the drill flute or bit surface.

Surface finish either zinc-plated, or black oxide to prevent rusting.

Made in USA.

Part Number	Hole Diameter	Outside Diameter	Width	Set-Screw Size
SESC-18	1/8"	3/8"	1/4"	#6-32
SESC-316	3/16"	3/8"	1/4"	#10-32
SESC-14	1/4"	1/2"	1/4"	#10-32
SESC-516	5/16"	5/8"	5/16"	#10-32
SESC-38	3/8"	3/4"	3/8"	1/4"-20
SESC-716	7/16"	7/8"	1/2"	1/4"-20
SESC-12	1/2"	1"	7/16"	1/4"-20
SESC-916	9/16"	1"	7/16"	1/4"-20
SESC-58	5/8"	1-1/8"	1/2"	1/4"-20
SESC-34	3/4"	1-1/4"	1/2"	5/16"-18
SESC-78	7/8"	1-3/8"	9/16"	5/16"-18
SESC-1	1"	1-1/2"	9/16"	5/16"-18

SESC-7Set Set of 7 collars as described above,
sizes: 1/8", 3/16", 1/4", 5/16", 3/8", 7/16" & 1/2".

SESC-4Set Set of 4 collars as described above,
sizes: 5/8", 3/4", 7/8" & 1".



Depth Collar

CHUCK, STYLE 1

For all types of machines where a 7/16"-14 threaded shank is needed.

Threaded shank 7/16"-14

Drill is held in place with a set screw.

Part Number	Hole Diameter	Outer Diameter	Overall Length	Rotational Direction
SE11125R	1/8"	5/8"	1-1/2"	right
SE11156R	5/32"	5/8"	1-1/2"	right
SE11187L	3/16"	5/8"	1-1/2"	left
SE11187R	3/16"	5/8"	1-1/2"	right
SE11218L	7/32"	5/8"	1-1/2"	left
SE11218R	7/32"	5/8"	1-1/2"	right
SE11250L	1/4"	5/8"	1-1/2"	left
SE11250R	1/4"	5/8"	1-1/2"	right
SE11281L	9/32"	5/8"	1-1/2"	left
SE11281R	9/32"	5/8"	1-1/2"	right
SE11312L	5/16"	7/8"	2-3/8"	left
SE11312R	5/16"	7/8"	2-3/8"	right
SE11375L	3/8"	7/8"	2-3/8"	left
SE11375R	3/8"	7/8"	2-3/8"	right
SE11393L	10mm	7/8"	2-3/8"	left
SE11393R	10mm	7/8"	2-3/8"	right
SE11437L	7/16"	7/8"	2-3/8"	left
SE11437R	7/16"	7/8"	2-3/8"	right
SE11500L	1/2"	7/8"	2-3/8"	left
SE11500R	1/2"	7/8"	2-3/8"	right



Chuck, Style 1

Drills

THREADED SHANK KEYED DRILL CHUCKS, STYLE 74

For use on boring machines requiring a 7/16"-14 threaded shank.

Industrial quality adjustable chucks for accuracy and long life.

Note: Overall length includes 5/8" of 7/16"-14 threads.

Part Number	Fits Sizes Inches	Fits Sizes Metric	Large Diameter	Overall Length
SE74003	1/32"-1/4"	0.5-6.5mm	1.26"	3 1/4"
SE74004	1/32"-3/8"	0.7-10mm	1.50"	3 3/4"
SE74005	5/64"-1/2"	2-13mm	1.68"	4 1/16"

Southeast Tool has a large line of industrial keyed chucks available. These cover most internal mounted Jacobs Taper styles, and a large selection of internal thread mounted chucks. Please check with us on any of your chuck needs as these are exceptional in quality and price.

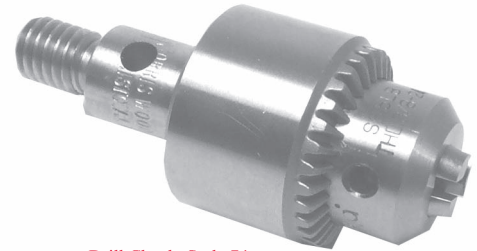

Drill Chuck, Style 74

Important Safety Information

- Never fail to remove the key from the chuck after using, always check before drill is turned on.
- Before mounting chuck to a spindle or arbor, thoroughly clean, then firmly press together.
- Never apply extensions of any kind to chuck key handles.
- Never subject chuck key handles to hammer or other impact blows.

1

2

3

4

5

6

7

8

9

10

Drills

CARBIDE-TIPPED STRAIGHT DOOR LITE BITS

Part Number	Cutting Diameter	Cutting Length	Shank Diameter	Overall Length
SEDL12-5	1/2"	2-1/4"	1/2"	5"
SEDL12	1/2"	2-1/4"	1/2"	5-1/2"
*SEDL12-F	1/2"	2-1/4"	1/2"	5-1/2"

**With (1) Flat on shank.*



SEDL 12-5

HIGH-SPEED STEEL SPIRAL DOOR BITS

Part Number	Cutting Diameter	Cutting Length	Shank Diameter	Overall Length	Coating
SEDOOR-53	1/2"	2-1/2"	1/2"	5-1/2"	Uncoated
SEDOOR-53M	1/2"	2-1/2"	1/2"	5-1/2"	Ceramic Based Coating
SEDOOR-53T	1/2"	2-1/2"	1/2"	5-1/2"	Tin Coated
SEDOOR-57F	1/2"	2-1/2"	1/2"	5-1/2"	With Flat
SEDOOR-57FT	1/2"	2-1/2"	1/2"	5-1/2"	Tin Coated w/ Flat
SEDOOR-60	1/2"	2-1/2"	1/2"	5-1/2"	Uncoated
SEDOOR-60T	1/2"	2-1/2"	1/2"	5-1/2"	Tin Coated

Coated for Extended Wear



SEDOOR-53



CARBIDE INSERT DRILL BIT WITH 1 FLAT ON SHANK

Part Number	Cutting Diameter	Shank Diameter	Overall Length
SEID218	2-1/8"	1/2"	5-3/4"

Part Number	Description
SI-141420	14 x14 x20mm insert (Box of 10) for Spur
SI-251215-2	25 x 12 x1.5mm insert (Box of 10) for Plow
SEM5-SCREW	M5 Spur Screw
SEM35-SCREW	M35 Plow Screw
SEC-POINT	2-51HC Center Drill
SEC-SCREW	6mm x 12mm Set Screw

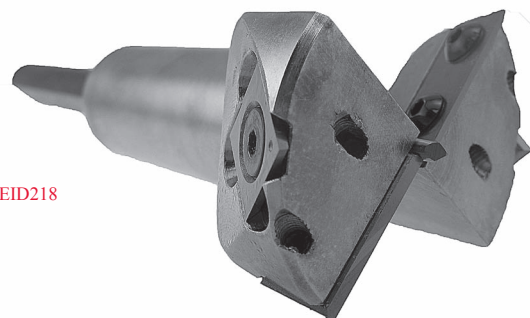

SEID218

Forstner Bits

Forstner Bits do NOT have a pronounced center point.
They give a true flat bottom hole

Carbon steel.

Part Number	Cutting Diameter	Shank Diameter	Shank Length	Overall Length
SE55001	1/4"	5/16"	4-3/4"	5"
SE55002	5/16"	5/16"	4-3/4"	5"
SE55003	3/8"	3/8"	4-3/4"	5"
SE55004	7/16"	1/2"	4-3/4"	5"
SE55005	1/2"	1/2"	4-3/4"	5"
SE55006	9/16"	1/2"	4-3/4"	5"
SE55007	5/8"	1/2"	4-3/4"	5"
SE55008	11/16"	1/2"	4-3/4"	5"
SE55009	3/4"	1/2"	4-11/16"	5"
SE55010	13/16"	1/2"	4-11/16"	5"
SE55011	7/8"	1/2"	4-9/16"	5"
SE55012	15/16"	1/2"	4-9/16"	5"
SE55013	1"	1/2"	4-9/16"	5"
SE55014	1-1/16"	1/2"	4-9/16"	5"
SE55015	1-1/8"	1/2"	4-7/16"	5"
SE55016	1-3/16"	1/2"	4-7/16"	5"
SE55017	1-1/4"	1/2"	4-1/2"	5"
SE55018	1-5/16"	1/2"	4-1/2"	5"
SE55019	1-3/8"	1/2"	4-1/2"	5"
SE55020	1-7/16"	1/2"	6"	6-3/4"
SE55021	1-1/2"	1/2"	6"	6-3/4"
SE55022	1-5/8"	1/2"	6-1/8"	6-3/4"
SE55023	1-3/4"	1/2"	6-1/8"	6-3/4"
SE55024	1-7/8"	1/2"	6-1/8"	6-3/4"
SE55025	2"	1/2"	6-1/8"	6-3/4"
SE55026	2-1/8"	1/2"	6-1/8"	6-3/4"
SE55027	2-1/4"	1/2"	5-7/8"	6-3/4"
SE55028	2-3/8"	1/2"	5-7/8"	6-3/4"
SE55029	2-1/2"	1/2"	5-7/8"	6-3/4"
SE55030	2-5/8"	1/2"	5-7/8"	6-3/4"
SE55031	2-3/4"	1/2"	5-7/8"	6-3/4"
SE55032	2-7/8"	1/2"	5-7/8"	6-3/4"
SE55033	3"	1/2"	5-7/8"	6-3/4"



Forstner Boring Bit
Style 55

Spade Bits

Carbon steel.

Part Number	Size	Overall Length
SE94620	5/16"	6"
SE94624	3/8"	6"
SE94628	7/16"	6"
SE94632	1/2"	6"
SE94636	9/16"	6"
SE94640	5/8"	6"
SE94644	11/16"	6"
SE94648	3/4"	6"
SE94652	13/16"	6"
SE94656	7/8"	6"
SE94660	15/16"	6"
SE94664	1"	6"
SE94708	1-1/8"	6"
SE94716	1-1/4"	6"
SE94724	1-3/8"	6"
SE94732	1-1/2"	6"



Spade Bit

1

2

3

4

5

6

7

8

9

10

Diamond-Tipped Router Bits • PCD

1+1 Design

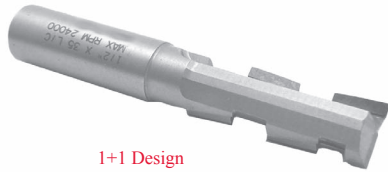

1+1 Design

Part Number	Cutting Diameter	Cutting Length	Shank Diameter	Overall Length
SE280003	3/8"	5/8"	1/2"	3"
SE280004	3/8"	1"	1/2"	2-3/4"
SE280009	1/2"	1"	1/2"	3"
SE280009A	1/2"	1-1/4"	1/2"	3-1/2"
SE280010	1/2"	1-3/8"	1/2"	3-1/8"
SE280012	5/8"	1"	5/8"	3-1/2"
SE280014	5/8"	1-3/8"	5/8"	4"
SE280018	3/4"	1"	3/4"	3-3/8"
SE280020	3/4"	1-3/8"	3/4"	3-3/4"
SE280011	3/4"	1-5/8"	3/4"	4"
SE280024	3/4"	2"	3/4"	4-1/2"

Diamond-Tipped T-Slot Bits • PCD

2+1 Design

2-3/8" Overall Length

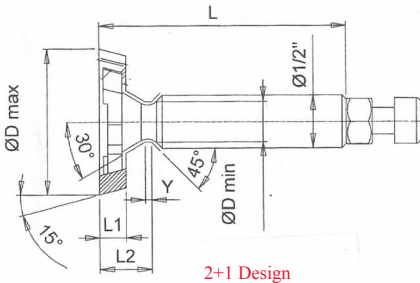

2+1 Design

Part Number	Maximum Diameter	Z	Length 1	Length 2	Shank	Rotation
SE293504	1 1/4"	2+1	1/4"	1/2"	1/2"	RH
SE293505	1 3/8"	2+1	1/4"	1/2"	1/2"	RH

Left-Hand Rotation Available

Diamond-Tipped T-Slot Bits • PCD • RH

2+1 Design

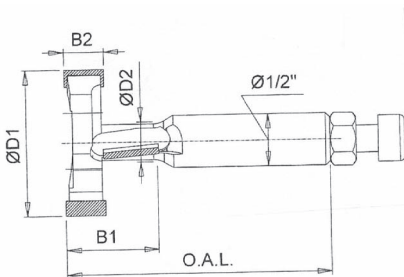

2+1 Design

Part Number	D1 Diameter	D2 Diameter	Cutting Length B1	Cutting Length B2	Shank Diameter	Overall Length
SE293005	1-3/16"	3/8"	5/8"	1/4"	1/2"	2-1/2"
SE293205	1-1/4"	3/8"	3/4"	1/4"	1/2"	2-1/2"
SE293507	1-3/8"	3/8"	3/4"	1/4"	1/2"	2-1/2"
SE293508	1-3/8"	3/8"	7/8"	3/8"	1/2"	2-1/2"

Left-Hand Rotation Available

CNC Woodworking Collets

SYOZ 20 FOR WOODWORKING MACHINES (RDO20)

This collet used on 6.8HP and 7HP dual end Perske® motors



SE03520-12

Part Number	Description	Diameter (mm)	Length (mm)	Inside Diameter
SE03520-03mm	SYOZ 20 3mm Collet	20	34	3mm
SE03520-18	SYOZ 20 1/8" Collet	20	34	1/8"
SE03520-316	SYOZ 20 3/16" Collet	20	34	3/16"
SE03520-05mm	SYOZ 20 5mm Collet	20	34	5mm
SE03520-14	SYOZ 20 1/4" Collet	20	34	1/4"
SE03520-516	SYOZ 20 5/16" Collet	20	34	5/16"
SE03520-38	SYOZ 20 3/8" Collet	20	34	3/8"
SE03520-10mm	SYOZ 20 10mm Collet	20	34	10mm
SE03520-716	SYOZ 20 7/16" Collet	20	34	7/16"
SE03520-12	SYOZ 20 1/2" Collet	20	34	1/2"

Other sizes available, call for pricing.

SYOZ 25 FOR WOODWORKING MACHINES (RDO35)

This collet used on 12HP and 15HP Perske® motors and 7.5 Dual End Perske® motors



SE03868-12

Part Number	Description	Diameter (mm)	Length (mm)	Inside Diameter
SE03868-18	SYOZ 25 1/8" Collet	35	52	1/8"
SE03868-316	SYOZ 25 3/16" Collet	35	52	3/16"
NEW SE03868-732	SYOZ 25 7/32" Collet	35	52	7/32"
SE03868-14	SYOZ 25 1/4" Collet	35	52	1/4"
SE03868-516	SYOZ 25 5/16" Collet	35	52	5/16"
SE03868-38	SYOZ 25 3/8" Collet	35	52	3/8"
SE03868-716	SYOZ 25 7/16" Collet	35	52	7/16"
SE03868-12	SYOZ 25 1/2" Collet	35	52	1/2"
SE03868-916	SYOZ 25 9/16" Collet	35	52	9/16"
SE03868-58	SYOZ 25 5/8" Collet	35	52	5/8"
SE03868-34	SYOZ 25 3/4" Collet	35	52	3/4"
SE03868-78	SYOZ 25 7/8" Collet	35	52	7/8"
SE03868-1	SYOZ 25 1" Collet	35	52	1"
NEW SE03868-7mm	SYOZ 25 7mm Collet	35	52	7mm
SE03868-10mm	SYOZ 25 10mm Collet	35	52	10mm
SE03868-16mm	SYOZ 25 16mm Collet	35	52	16mm
SE03868-20mm	SYOZ 25 20mm Collet	35	52	20mm
SE03868-25mm	SYOZ 25 25mm Collet	35	52	25mm

Other sizes available, call for pricing.

ULTRA HIGH-SPEED COATED CLAMPING NUTS

Compatible with RDO and Ortlieb Nuts Above

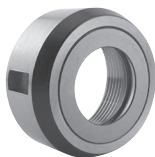

SE03868 Nut

Part Number	Description	Diameter (mm)	Length (mm)	
NEW SE03508	EOC 08	30	19	
SE03520	SYOZ 20/RDO 20	35	20	
SE03868	SYOZ 25/RDO 35	60	30	
SE03520-L	SYOZ 20/RDO 20	35	20	Lefthand
SE03868-L	SYOZ 25/RDO 35	60	30	Lefthand

SPANNER WRENCHES

For SYOZ 20 and SYOZ 25 Above

Part Number	Type
SE22220	SYOZ 20/RDO 20
SE03691	SYOZ 25/RDO 35

1

2

3

4

5

6

7

8

9

10

CNC Woodworking Collets

SHODA® COLLETS (OLD STYLE)

Part Number	Description	Diameter (A) (mm)	Length (L) (mm)	Inside Diameter (d)
SESD-20mm-.250	20mm (old style) 1/4"	20	52	.250"
SESD-20mm-.312	20mm (old style) 5/16"	20	52	.312"
SESD-20mm-.375	20mm (old style) 3/8"	20	52	.375"
SESD-20mm-.500	20mm (old style) 1/2"	20	52	.500"
SESD-20mm-.625	20mm (old style) 5/8"	20	52	.625"
SESD-20mm-Nut	Old Style Nut	41	30	

SESD-20mm

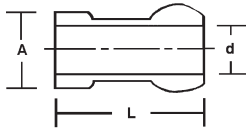

SHODA® COLLETS (PIGGY BACK)

Part Number	Description	Diameter (A) (mm)	Length (L) (mm)	Inside Diameter (d)
SESD-C001-.125	Piggy back 1/8" Collet	16	52	.125"
SESD-C001-.187	Piggy back 3/16" Collet	16	52	.187"
SESD-C001-.250	Piggy back 1/4" Collet	16	52	.250"
SESD-C001-.312	Piggy back 5/16" Collet	16	52	.312"
SESD-C001-.375	Piggy back 3/8" Collet	16	52	.375"
SESD-C001-.500	Piggy back 1/2" Collet	16	52	.500"
SESD-C001-10mm	Piggy back 10mm Collet	16	52	10mm
SESD-C001-Nut	Nut for Piggy back	36	30	

SESD-C001

SHODA® COLLETS (NEW STYLE)

Part Number	Description	Diameter (A) (mm)	Length (L) (mm)	Inside Diameter (d)
SESD-C015-.125	Shoda® 24mm (new style) 1/8	24	52	.125"
SESD-C015-.250	Shoda® 24mm (new style) 1/4	24	52	.250"
SESD-C015-.312	Shoda® 24mm (new style) 5/16	24	52	.312"
SESD-C015-.375	Shoda® 24mm (new style) 3/8	24	52	.375"
SESD-C015-.500	Shoda® 24mm (new style) 1/2	24	52	.500"
SESD-C015-.625	Shoda® 24mm (new style) 5/8	24	52	.625"
SESD-C015-.750	Shoda® 24mm (new style) 3/4	24	52	.750"
SESD-C015-10mm	Shoda® 24mm (new style) 10mm	24	52	10mm
SESD-C015-Nut	Nut for New Style	46	30	

SESD-C015

SHODA® COLLETS (SUPER SHODA®)

Part Number	Description	Diameter (A) (mm)	Length (L) (mm)	Inside Diameter (d)
SESS-22-14	Super Shoda® 30,000 RPM	23	40	.250"
SESS-22-38	Super Shoda® 30,000 RPM	23	40	3/8"
SESS-22-10mm	Super Shoda® 30,000 RPM	23	40	10mm
SESS-22-12	Super Shoda® 30,000 RPM	23	40	1/2"
NEW SESS-22-58	Super Shoda® 30,000 RPM	23	40	5/8"
SESS-22-Nut	Nut for Super Shoda®	36	15	
NEW SESS-22-ext-nut	Extended Nut for Super Shoda®	36	30	

SESS-22

Super Shoda® Nut

NEW

NEW

Other sizes available, call for pricing.

SHODA® NUTS

Part Number	Description	Diameter (A) (mm)	Length (L) (mm)
SESD-20mm-Nut	Old Style Nut	41	30
SESD-C001-Nut	Piggyback Nut	36	30
SESD-C015-Nut	New Style Nut	46	30
SESS-22-Nut	Super Shoda® Nut	36	15
NEW SESS-22-ext-nut	Nut for Super Shoda®	36	30

Super Shoda®
Extended Nut



Shoda® New
Style Nut

ER CNC Woodworking Collets

PLEASE

 at our
NEW SIZES!



Collet ER32

ER PRECISION COLLETS

Inch Sizes • Standard .0004" TIR

ER11	ER16	ER20	ER25	ER32	ER40	Shank
SE04211-116	SE04216-116					1/16"
SE04211-332	SE04216-332	SE04220-332	SE04225-332	SE04232-332		3/32"
SE04211-18	SE04216-18	SE04220-18	SE04225-18	SE04232-18	SE04240-18	1/8"
SE04211-532	SE04216-532	SE04220-532	SE04225-532	SE04232-532	SE04240-532	5/32"
SE04211-316	SE04216-316	SE04220-316	SE04225-316	SE04232-316	SE04240-316	3/16"
SE04211-732	SE04216-732	SE04220-732	SE04225-732	SE04232-732	SE04240-732	7/32"
SE04211-14	SE04216-14	SE04220-14	SE04225-14	SE04232-14	SE04240-14	1/4"
	SE04216-932	SE04220-932	SE04225-932	SE04232-932	SE04240-932	9/32"
	SE04216-516	SE04220-516	SE04225-516	SE04232-516	SE04240-516	5/16"
	SE04216-1132	SE04220-1132	SE04225-1132	SE04232-1132	SE04240-1132	11/32"
	SE04216-38	SE04220-38	SE04225-38	SE04232-38	SE04240-38	3/8"
	SE04216-1332	SE04220-1332	SE04225-1332	SE04232-1332	SE04240-1332	13/32"
		SE04220-716	SE04225-716	SE04232-716	SE04240-716	7/16"
		SE04220-1532	SE04225-1532	SE04232-1532	SE04240-1532	15/32"
		SE04220-12	SE04225-12	SE04232-12	SE04240-12	1/2"
			SE04225-1732	SE04232-1732	SE04240-1732	17/32"
			SE04225-916	SE04232-916	SE04240-916	9/16"
			SE04225-1932	SE04232-1932	SE04240-1932	19/32"
			SE04225-58	SE04232-58	SE04240-58	5/8"
				SE04232-2132	SE04240-2132	21/32"
				SE04232-1116	SE04240-1116	11/16"
				SE04232-2332	SE04240-2332	23/32"
			SE04225-34	SE04232-34	SE04240-34	3/4"
					SE04240-1	1"

ER PRECISION COLLETS

Metric Sizes (note mm is part of the part number)



Collet ER32

ER16	ER20	ER25	ER32	ER40	Shank
		SE04225-2mm			2mm
			SE04232-5mm		5mm
			SE04232-6mm		6mm
SE04216-7mm	SE04220-7mm	SE04225-7mm	SE04232-7mm	SE04240-7mm	7mm
SE04216-8mm	SE04220-8mm	SE04225-8mm	SE04232-8mm	SE04240-8mm	8mm
SE04216-10mm	SE04220-10mm	SE04225-10mm	SE04232-10mm	SE04240-10mm	10mm
	SE04220-12mm	SE04225-12mm	SE04232-12mm	SE04240-12mm	12mm
	SE04220-13mm	SE04225-13mm	SE04232-13mm	SE04240-13mm	13mm
		SE04225-14mm	SE04232-14mm	SE04240-14mm	14mm
		SE04225-16mm	SE04232-16mm	SE04240-16mm	16mm
		SE04225-18mm	SE04232-18mm	SE04240-18mm	18mm
			SE04232-20mm	SE04240-20mm	20mm
				SE04240-25mm	25mm

See Chart on page 105 for dimensions.
 Other sizes available. Call for pricing.



Collet Set

ER PRECISION COLLET SETS

Part Number	Description	Range	Includes
SE04205	ER32-Metric (18 pc. Set)	2mm-20mm	3-20mm
SE04211	ER25 (16 pc. Set)	1/8"-5/8"	5/32"-5/8"
SE04212	ER32 (18 pc. Set)	3/16"-3/4"	7/32"-3/4"
SE04213	ER40 (13 pc. Set)	1/8"-1"	1/8"-1"

Sets come in wooden tray. Wooden tray also sold separately.

1

2

3

4

5

6

7

8

9

10

CNC Woodworking Collets

TG PRECISION COLLETS



TG75	TG100	TG150	SHANK
NEW SE04008-18	SE04010-18		1/8"
NEW SE04008-316			3/16"
SE04008-14	SE04010-14		1/4"
SE04008-38	SE04010-38		3/8"
SE04008-12	SE04010-12	SE04011-12	1/2"
SE04008-58	SE04010-58	SE04011-58	5/8"
SE04008-34	SE04010-34	SE04011-34	3/4"
	SE04010-78	SE04011-78	7/8"
	SE04010-1	SE04011-1	1"

NEW SE04008-nut

*See Chart on page 105 for dimensions.
Other sizes available. Call for pricing.*

HEIAN® COLLETS



Heian® Collet

Part Number	Description
SEHN-24mm-.187	3/16" Heian® Collet (24mm)
SEHN-24mm-.375	3/8" Heian® Collet (24mm)
SEHN-24mm-.500	1/2" Heian® Collet (24mm)
SEHN-24mm-.625	5/8" Heian® Collet (24mm)
SEHN-24mm-.750	3/4" Heian® Collet (24mm)
SEHN-24mm-10	10mm Heian® Collet (24mm)
SEHN-24mm-20	20mm Heian® Collet (24mm)
SEHN-29mm-.187	3/16" Heian® Collet (29mm)
SEHN-29mm-.500	1/2" Heian® Collet (29mm)
SEHN-29mm-.750	3/4" Heian® Collet (29mm)
SEHN-Piggyback-14	1/4" Heian® Piggyback Collet
SEHN-Piggyback-38	3/8" Heian® Piggyback Collet
SEHN-Piggyback-12	1/2" Heian® Piggyback Collet
SEHN-Piggyback-58	5/8" Heian® Piggyback Collet

NEW ER Bearing Nuts



ER32 Bearing Nut

Part Number	Description	Inside Diameter	Length	Spanner	Maximum Clamp Torque
SE21225	ER25 Bearing Nut	42	21	22.5	SE04615 95 ft. lbs.
SE21232	ER32 Bearing Nut	50	22	25	SE04616 125 ft. lbs.
SE21240	ER40 Bearing Nut	63	34	28	SE04617 140 ft. lbs.

ER High-Speed Coated Nuts



ER32 Coated Nut

Part Number	Description	Inside Diameter	Length	Spanner	Maximum Clamp Torque
SE46111	ER11 High Speed Nut	19	14 x .75	11.8	SE04608 20 ft. lbs.
SE46116	ER16 High Speed Nut	32	22 x 1.5	18	SE04613 50 ft. lbs.
SE46120	ER20 High Speed Nut	35	25 x 1.5	19.5	SE04614 75 ft. lbs.
SE46125	ER25 High Speed Nut	42	32 x 1.5	20.5	SE04615 95 ft. lbs.
SE46132	ER32 High Speed Nut	50	40 x 1.5	23	SE04616 125 ft. lbs.
SE46140	ER40 High Speed Nut	63	50 x 1.5	26	SE04617 140 ft. lbs.

*Coated nuts give up to 100% more clamping pressure over bearing nuts.
For use when speeds exceed 15,000 rpm.
Recommended torque is 80 to 90% of max value.*

Easy Collet Reference Sheet

**ALMOST ALL COLLETS HAVE A DISTINCTIVE LENGTH AND DIAMETER.
USE THE REFERENCE SHEET BELOW TO DETERMINE YOUR COLLET TYPE.**

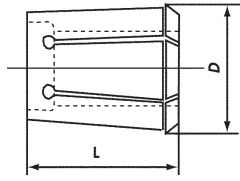

ER Collet

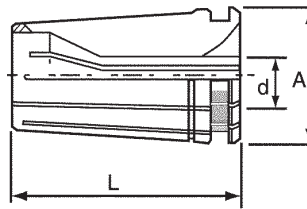

TG Collet

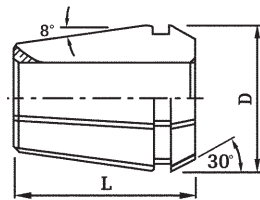

SYOZ Collet

COLLET SERIES	LENGTH	DIAMETER
ER 11	18mm (0.708")	11.5mm (0.45")
ER 16	27.5mm (1.08")	17mm (0.67")
ER 20	31.5mm (1.24")	21mm (0.83")
ER 25	34mm (1.34")	26mm (1.02")
ER 32	40mm (1.57")	33mm (1.31")
ER 40	46mm (1.81")	41mm (1.61")
NEW ER 50	60mm (2.36")	52mm (2.05")
NEW EOC 8	26mm (1.026")	14.4mm(0.567")
SYOZ 20 • RDO 20 • EOC 12 • 407E	34mm (1.34")	20mm (0.78")
EOC 16 • RDO 25	40mm (1.57")	25.5mm (1")
SYOZ 25 • RDO 35 • 462E	52mm (2.06")	35mm (1.38")
NEW EOC 32	60mm (2.36")	43.7mm (1.72")
TG 75	47mm (1.85")	27mm (1.06")
TG 100	60mm (2.36")	35mm (1.38")
TG 150	76.2mm (3.00")	50.8mm (2.00")

Shoda® Collets

SD-20mm	52mm (2.06")	20mm (Back side)
SD-C001	52mm (2.06")	16mm (Back side)
SD-C015	52mm (2.06")	24mm (Back side)
SS-22	40mm (1.57")	22.5mm 0.89" (OD)

Heian® Collets

HN-24mm	55mm (2.16")	24mm (Back side)
HN-29mm	55mm (2.16")	29mm (Back side)
HN-Piggyback	36.5mm (1.43")	22mm (Back side)

ER Spanner Wrenches

TYPE A, UM, RU, M



Slotted Wrench



Hook Wrench



Hex Wrench



Mini Wrench



A Hex Wrench

Part Number	Diameter	Collet Nut	Length	Width	Nut Type
SE04608	ER11 Wrench	SE46111	120	40	A (Hex)
SE04609	ER16 Wrench	SE46116	140	53	A (Hex)
SE04610	ER20 Wrench	SE41120	180	60	A (Hex)
NEW SE04613	ER16 Wrench	SE41616	160	55	Slotted
NEW SE04614	ER20 Wrench	SE41620	180	60	Slotted
SE04615	ER25 Wrench	SE46125	206	65	Slotted
SE04616	ER32 Wrench	SE46132	253	75	Slotted
SE04617	ER40 Wrench	SE46140	289	90	Slotted
NEW SE04618	ER50 Wrench	SE41950	351	110	Slotted
SE04620	ER 8 Wrench	SE23108	75	13	ER Mini
SE04621	ER 11 Wrench	SE23111	95	17	ER Mini
SE04622	ER 16 Wrench	SE23116	117	22.5	ER Mini
SE04623	ER 20 Wrench	SE23120	129	28.5	ER Mini
SE04624	ER 25 Wrench	SE23125	142.5	35.5	ER Mini
NEW SE04018	TG 75 Wrench	SE27500	253	46	Hook
NEW SE03691	TG 100 / SYOZ 25 Wrench	SE28110	260	46	Hook
NEW SE22220	SYOZ 20 Wrench	SE03520		34	Hook

Tool Holders For CNC Routers

ISO AND SK COLLET HOLDERS Balanced to 25,000 RPM @ G2.5

Collet Nuts are included with holder.



ISO Holder

Collet Nuts are included with holder.

Part Number	Description	D	A	F	N	Flat	Wrench
SE06000-2016M	ISO 20 x ER 16M-52mm	30	52	15.9	22	17	SE04622
SE06000-2516	ISO 20 x ER 16-52mm	30	52	15.9	32	17	SE04613
SE06000-2520	ISO 20 x ER 20-52mm	30	52	15.9	35	17	SE04614
SE12407-W	ISO 30 x ER 11M-100mm	50	100	15.9	16	14	SE04621
SE12000-CMS	ISO 30 x ER 32-CMS	46	58	15.9	50	36	SE04616
SE12040	ISO 30 x ER 40-CMS	46	66	15.9	63	42	SE04617
SE12213-W-50	ISO 30 x ER 32-50mm	50	50	15.9	50	47	SE04616
SE12213-W-50-L	ISO 30 x ER 32-50mm Left	50	50	15.9	50	47	SE04616
SE12213-W-63	ISO 30 x ER 32-63mm	50	63	15.9	50	36	SE04616
SE12213-W-63-L	ISO 30 x ER 32-63mm Left	50	63	15.9	50	36	SE04616
SE12213-W-90	ISO 30 x ER 32-90mm	50	90	15.9	50	36	SE04616
SE12215-W-57	ISO 30 x ER 40-57mm	50	57	15.9	63	47	SE04617
SEPE30DF2056	ISO 30 x ER 32	46	58	15.9	50	36	SE04616
SEPE30DM20	ISO 30 x ER 32 W/Locking Teeth						SE04616
SE12261-W	ISO 40 x ER40-70mm	63.55	70	15.9	63	46	SE04617

Andi® / Weeke® / Thermwood® CNC Chucks

Part Number	Description	D	A	F	N	Flat	Wrench
SENT-54300130	SK-30 x OZ 25 Toolholder	50	70	15.9	60	38	SE03691
SENT-54300130-L	SK-30 x OZ 25 LH Toolholder	50	70	15.9	60	38	SE03691
SEISO-30-THERM	Thermwood ISO 30 x ER32-50mm	57	45	None	50	20	SE04616

Collet Nuts are included with holder.

Dimensions in millimeters.

BT30 Chucks

Part Number	Description	D	A	F	N	Wrench
SE06106-W	BT30 x ER 20-70mm w/o Slots	46	70	20	34	SE04614
NEW SE06106-slotnut	BT30 x ER20-70mm w/ Slots	46	70	20	35	SE04614
NEW SE06107	BT30 x ER20-135mm w/o Slots	46	135	20	35	SE04614
NEW SE06107-slotnut	BT30 x ER20-135mm w/ Slots	46	135	20	35	SE04614
NEW SE06108-2.5	BT30 x ER20-2.5" w/o Slots	46	63.5	20	34	SE04610
NEW SE06108-2.5-slotnut	BT30 x ER20-2.5" w/ Slots	46	63.5	20	35	SE04614
NEW SE06109	BT30 x ER25-70mm	46	70	20	42	SE04615
NEW SE06110-W-60	BT30 x ER25-60mm	46	60	20	42	SE04615
NEW SE06111	BT30 x ER25-135mm	46	135	20	42	SE04615
NEW SE06111-90	BT30 x ER25-90mm	46	90	20	42	SE04615
SE06112	BT30 x ER 32-60mm w/ Slots	46	60	20	50	SE04616
SE06113-W-60	BT30 x ER 32-60mm w/o Slots	46	60	20	50	SE04616
NEW SE06113-W-60-A	BT30 x ER32-60mm Komo	46	60	20	50	SE04616
SE06113-W-60L	BT30 x ER 32-60mm Left Hand	46	60	20	50	SE04616
SE06113	BT30 x ER 32-70 w/ Slots	46	70	20	50	SE04616
SE06113-W-90	BT30 x ER 32-90mm w/o Slots	46	90	20	50	SE04616
NEW SE06114	BT30 x ER 32-100mm	46	100	20	50	SE04616
NEW SE06115	BT30 x ER40-80mm	46	80	20	63	SE04616
SE06001-W	BT30 x SYOZ 25-70mm w/o Slots	46	70	20	60	SE03691
SE06001	BT30 x SYOZ 25-70mm	46	70	20	60	SE03691

*Pull Stud Included 41mm Flats Komo

BT35 Chucks

SE06010	BT35 x SYOZ 25-76mm	53	76	22	60	SE03691
SE061BT353276	BT35 x ER 32-76mm	53	76	22	50	SE04616

Collet Nut are included with holder.

Dimensions in millimeters.

HSK Collet Toolholders For CNC Routers

HSK E COLLET TOOLHOLDERS

Part Number	Description	D	d1	L1	L2	Flats	Wrench
NEW SE31374-60	HSK 32E x ER25	32mm	42mm	60mm	45mm	22mm	SE04615
SE8905001	HSK 40E x ER16 - 65	40mm	28mm	65mm	45mm	24mm	SE04613
SE8905002	HSK 40E x ER25 - 75	40mm	42mm	75mm	55mm	27mm	SE04615
SE8905003	HSK 40E x ER32 - 100	40mm	50mm	100mm	80mm	35mm	SE04616
SE8505002	HSK 50E x ER32 - 85	50mm	50mm	85mm	59mm	36mm	SE04616
SE8605002	HSK 63E x ER32 - 90	63mm	50mm	90mm	64mm	None	SE04616
SE8605003	HSK 63E x ER40 - 120	63mm	63mm	120mm	94mm	None	SE04617
SE50001	HSK 63E x ER40 - 75	63mm	63mm	75mm	49mm	None	SE04617

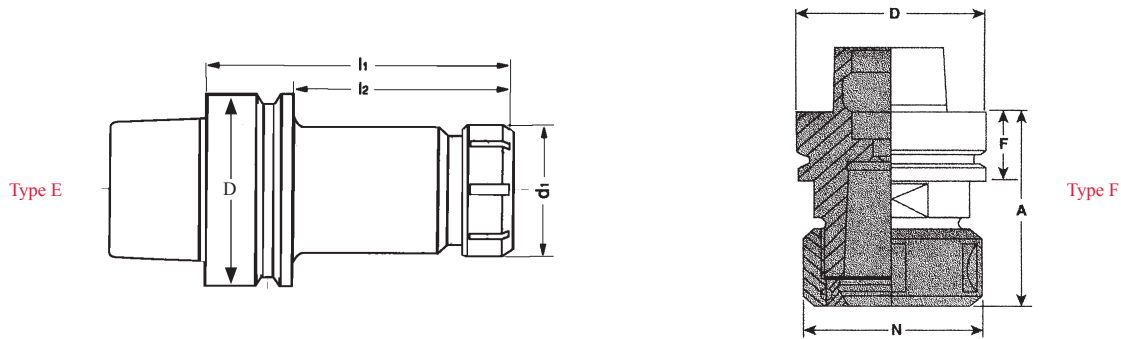

HSK F COLLET TOOLHOLDERS

Part Number	Description	D	A	F	N	Flats	Wrench
SE40050	HSK 50F x ER32 - 80mm	50mm	80mm	26mm	50mm	NONE	SE04616
SE17105-008001	HSK 63F x ER16 - 60mm	63mm	60mm	26mm	32mm	26mm	SE04613
SE17105-008002	HSK 63F x ER16 - 100mm	63mm	100mm	26mm	32mm	26mm	SE04613
SE30000	HSK 63F x ER32 - 70mm	63mm	70mm	26mm	50mm	36mm	SE04616
SE30001	HSK 63F x ER40 - 76mm	63mm	76mm	26mm	63mm	46mm	SE04617
SE30002	HSK 63F x ER40 - 90mm	63mm	90mm	26mm	63mm	46mm	SE04617
SE30005	HSK 63F x ER40 - 125mm	63mm	125mm	26mm	63mm	46mm	SE04617
SE41025	HSK 63F x SYOZ 25 - 80mm	63mm	80mm	26mm	60mm	38mm	SE03691

ER Tool Extenders

Extension length should not exceed a 4:1 ratio of length to diameter. For example, a 1/2" shank should not extend more than 2" in front of the holder. This is true only for applications where the extension is rotating.

Part Number	Shank	Overall Length	Diameter	Collet	Wrench	Nut
SE04889	3/8"	124mm	12mm	ER8	SE04620	SE23108
SE04891	1/2"	166.5mm	16mm	ER11	SE04621	SE23111
SE04893	5/8"	158.5mm	16mm	ER11	SE04621	SE23111
SE04895	1/2"	177mm	22mm	ER16	SE04622	SE23116
SE04896	3/4"	165mm	22mm	ER16	SE04622	SE23116
NEW SE04894	3/4"	180mm	28mm	ER20	SE04623	SE23120
SE04897	1"	168mm	28mm	ER20	SE04623	SE23120
NEW SE04888	1"	190mm	35mm	ER25	SE04624	SE23125
SE04898	3/4"	140mm	35mm	ER25	SE04624	SE23125

*Extenders have threaded thru holes for a backup screw. Includes nut.
Collet and wrench sold separately*



HSK Hydraulic Toolholders For CNC

HSK F HYDRAULIC TOOLHOLDERS

Part Number	Type	d1	d2	d3	d	L2	L1
SE17105036-016	HSK 63F Hydro Chuck 20mm ID	20	42	50	63	58	100
SE17105036-018	HSK 63F Hydro Chuck 32mm ID	32	60	50	63	59	125
SE17105036-020	HSK 63F Hydro Chuck 25mm ID	25	44	50	63	23	85
SE17105036-035	HSK 63F Hydro Chuck 1" ID	1.0"	44	50	63	23	85



ISO 30 HYDRAULIC TOOLHOLDERS

Part Number	Type	d1	d2	d3	d	L2	L1
SE6405043-224	ISO / SK 30 Hydro Chuck 3/4" ID	3/4"	70	45	50	44	60
SE6405043-225	ISO / SK 30 Hydro Chuck 1" ID	1"	70	45	50	44	60

Dimensions in millimeters unless otherwise indicated.



Reducing Sleeves for Hydraulic Toolholders

INCH OD / INCH ID

Part Number	Description	d1	D	D1	L	L1	L2
SE05024-130	3/4" OD X 1/8" ID	0.125"	0.750"	0.945"	2.083"	2.003"	0.079"
SE05024-131	3/4" OD X 3/16" ID	0.1875"	0.750"	0.945"	2.083"	2.003"	0.079"
SE05024-132	3/4" OD X 1/4" ID	0.250"	0.750"	0.945"	2.083"	2.003"	0.079"
SE05024-133	3/4" OD X 5/16" ID	0.3125"	0.750"	0.945"	2.083"	2.003"	0.079"
SE05024-134	3/4" OD X 3/8" ID	0.375"	0.750"	0.945"	2.083"	2.003"	0.079"
SE05024-135	3/4" OD X 7/16" ID	0.4375"	0.750"	0.945"	2.083"	2.003"	0.079"
SE05024-136	3/4" OD X 1/2" ID	0.500"	0.750"	0.945"	2.083"	2.003"	0.079"
SE05024-137	3/4" OD X 5/8" ID	0.625"	0.750"	0.945"	2.083"	2.003"	0.079"

T.I.R. only .00012"

METRIC OD / INCH ID

Part Number	Description	d1	D	D1	L	L1	L2
SE05024-114	20mm OD X 1/4" ID	0.250"	20mm	24mm	52.9mm	50.9mm	2mm
SE05024-116	20mm OD X 5/16" ID	0.3150"	20mm	24mm	52.9mm	50.9mm	2mm
SE05024-118	20mm OD X 3/8" ID	0.375"	20mm	24mm	52.9mm	50.9mm	2mm
SE05024-120	20mm OD X 7/16" ID	0.4375"	20mm	24mm	52.9mm	50.9mm	2mm
SE05024-122	20mm OD X 1/2" ID	0.500"	20mm	24mm	52.9mm	50.9mm	2mm
SE05024-126	20mm OD X 5/8" ID	0.625"	20mm	24mm	52.9mm	50.9mm	2mm

METRIC OD / METRIC ID

Part Number	Description	d1	D	D1	L	L1	L2
SE05024-001	20mm OD X 6mm ID	6mm	20mm	24mm	52.9mm	50.9mm	2mm
SE05024-002	20mm OD X 8mm ID	8mm	20mm	24mm	52.9mm	50.9mm	2mm
SE05024-003	20mm OD X 10mm ID	10mm	20mm	24mm	52.9mm	50.9mm	2mm
SE05024-004	20mm OD X 12mm ID	12mm	20mm	24mm	52.9mm	50.9mm	2mm
SE05024-005	20mm OD X 14mm ID	14mm	20mm	24mm	52.9mm	50.9mm	2mm
SE05024-006	20mm OD X 16mm ID	16mm	20mm	24mm	52.9mm	50.9mm	2mm
SE05024-012	32mm OD X 10mm ID	10mm	32mm	40mm	66mm	62mm	4mm
SE05024-013	32mm OD X 12mm ID	12mm	32mm	40mm	66mm	62mm	4mm
SE05024-014	32mm OD X 14mm ID	14mm	32mm	40mm	66mm	62mm	4mm
SE05024-015	32mm OD X 16mm ID	16mm	32mm	40mm	66mm	62mm	4mm
SE05024-016	32mm OD X 18mm ID	18mm	32mm	40mm	66mm	62mm	4mm
SE05024-018	32mm OD X 20mm ID	20mm	32mm	40mm	66mm	62mm	4mm
SE05024-020	32mm OD X 25mm ID	25mm	32mm	40mm	66mm	62mm	4mm

ER Mini Nuts

Part Number	Description	D	B	M	Wrench	Maximum Torque
SE23108	ER 8 Mini Nut	12mm	11mm	M10 x 0.75	SE04620	7 ft/lbs
SE23111	ER 11 Mini Nut	16mm	12mm	M13 x 0.75	SE04621	14 ft/lbs
SE23116	ER 16 Mini Nut	22mm	18mm	M19 x 1.0	SE04622	22 ft/lbs
SE23120	ER 20 Mini Nut	28mm	19.5mm	M24 x 1.0	SE04623	25 ft/lbs
SE23125	ER 25 Mini Nut	35mm	21mm	M30 x 1.0	SE04624	29 ft/lbs

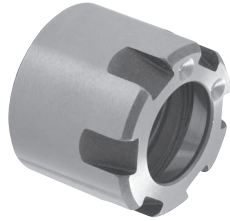

ER High-Speed Nut

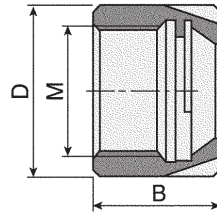

HIGH-SPEED

Use ER High-Speed mini nuts for applications where speed exceeds 10,000 RPMs. They are balanced to G2.5 for 20,000 RPMs. These nuts are used on collet holders and multi-spindle heads where center or shoulder distances are important.

Part Number	Description	D	B	M	Wrench	Maximum Torque
SE33108	ER 8 HS Mini Nut	12mm	11mm	M10 x 0.75	SE04620	7 ft/lbs
SE33111	ER 11 HS Mini Nut	16mm	12mm	M13 x 0.75	SE04621	14 ft/lbs
SE33116	ER 16 HS Mini Nut	22mm	18mm	M19 x 1.0	SE04622	22 ft/lbs
SE33120	ER 20 HS Mini Nut	28mm	19.5mm	M24 x 1.0	SE04623	25 ft/lbs
SE33125	ER 25 HS Mini Nut	35mm	21mm	M30 x 1.0	SE04624	29 ft/lbs
SE33125-L	ER 25 HS L-Hand Nut	35mm	21mm	M30 x 1.0	SE04624	29 ft/lbs

Pull Studs For CNC Routers

(Retention Knobs)

Part Number	Type	D	d1	d2	d3	L	L1	L2	°	T
SE750-19	KOMO 30-A12.5	17	13	9	12.5	44	23.4	18.2	15°	M12
SE13001	DAT 30-A	17	13	9	13	44	24	19	15°	M12
SE13003	DAT 40-A	23	19	14	17	54	26	20	15°	M16
SE13001-45	Colombo 30 Ball	17	12.8	9	13	44	24	19	45°	M12
SE13019	HSD ISO30	17	12	8	13	44	23.9	—	Radius	M12
SE07801	BT 30-45°	16.5	11	7	12.5	43	23	—	45°	M12
SE07803	BT 40-45°	23	15	10	17	60	35	28	—	M16
SE07805	BT 50-45°	38	23	17	25	85	45	35	—	M24
SE07806	BT 30-60°	16.5	11	7	12.5	43	23	—	—	M12
SE07808	BT 40-60°	23	15	10	17	60	35	28	60°	M16
SE07810	BT 50-60°	38	23	17	25	85	45	35	—	M24
SE07812	BT 30-90°	16.5	11	7	12.5	43	23	8	—	M12
SE07814	BT 40-90°	23	15	10	17	60	35	28	—	M16
SE4403502	BT 35-Heian	20	13	8.5	12.5	48	28	22.5	15°	M12

SE13001	Colombo Spindles
SE13001-45	Columbo Spindles Clamping by Balls
SE750-19	Komo Router for BT30 Holder
SE13019	HSD Spindles

Please make sure that the pull stud you order is the exact pull stud your machine uses. Improper choice of a pull stud can cause damage to your machine spindle, the tool holder, and can cause a serious safety hazard.

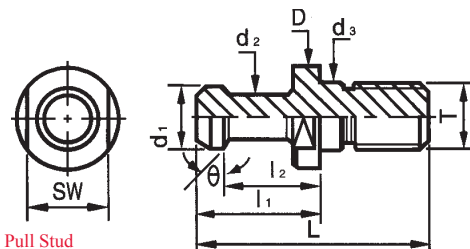

Pull Stud

ISO 30 & HSK 63F Arbors

Part Number	Description	L	GL	D	B	N
SE12700-40	ISO 30 x 1 1/4" x 40mm arbor	40mm	42mm	1-1/4"	20mm	42mm
SE12700-55	ISO 30 x 1 1/4" x 55mm arbor	55mm	42mm	1-1/4"	20mm	42mm
SE12700-80	ISO 30 x 1 1/4" x 80mm arbor	80mm	42mm	1-1/4"	20mm	42mm
SE12700-100	ISO 30 x 1 1/4" x 100mm arbor	100mm	42mm	1-1/4"	20mm	42mm

Special sizes made to your specifications. Contact us for details.



ISO 30

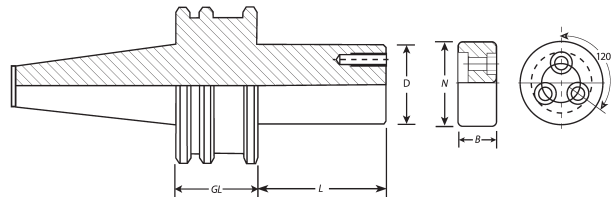

Special 3 screw design for enhanced safety

Part Number	Description	D	L	N	B	GL
SE41060	HSK 63F 1 1/4" arbor x 55mm	1-1/4"	55mm	42mm	20mm	45mm
SE41080-3H	HSK 63F 1 1/4" arbor x 80mm	1-1/4"	80mm	42mm	20mm	45mm
SE41085	HSK 63F 1 1/4" arbor x 100mm	1-1/4"	100mm	42mm	20mm	45mm
SE41087	HSK 63F 1 1/4" arbor x 112mm	1-1/4"	112mm	42mm	20mm	45mm



HSK 63F

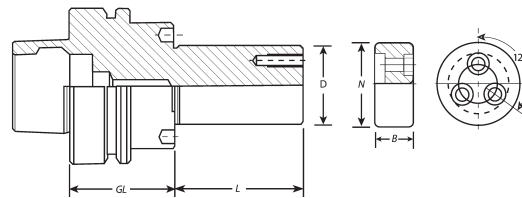

Tightening Stand For ISO, HSK63 & BT30

Part Number	Description	Tool Holder Used For
SENTS-ISO30-36	ISO 30-36mm Flats	12213-W-63, 12213-W-90
SENTS-ISO30-38	ISO 30-38mm Flats	NT-5400130
SENTS-ISO30-47	ISO 30-47mm Flats	12213-W-50, 12215-W-57
NEW SENTS-BT30-38	BT30 Taper 38mm Flats	
NEW SENTS-BT30-SLOT	BT30 with Drive Slots	
SENTS-BT30-41	BT 30 - Taper 41mm Flats	06113-W-60
NEW SENTS-HSK63A	HSK 63A No Flats	
SENTS-HSK63F-36	HSK 63F - 36mm Flats	30000
SENTS-HSK63F-38	HSK 63F - 38mm Flats	41025
NEW SENTS-HSK63F-41	HSK 63F - 41mm Flats	
SENTS-HSK63F-46	HSK 63F - 46mm Flats	30001, 30005, 50001



- New design for easy access to pull studs from bottom
- Constructed of precision machined anodized alloy
- Outstanding strength, speed, and durability
- Securely bolts right on CNC Machine or workbench

CNC Accessories

DUST COVERS FOR COLLET NUTS • 1 1/2" DIAMETER X 1/4" THICK

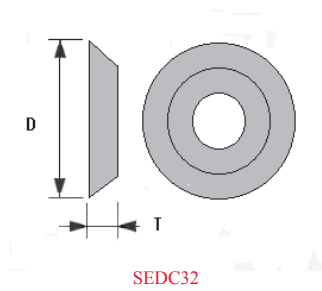

Part Number	Description
SEDC32-316	Dust Cover 3/16" Shank
SEDC32-14	Dust Cover 1/4" Shank
SEDC32-516	Dust Cover 5/16" Shank
SEDC32-38	Dust Cover 3/8" or 10 mm Shank
SEDC32-12	Dust Cover 1/2" Shank
SEDC32-58	Dust Cover 5/8" Shank
SEDC32-34	Dust Cover 3/4" Shank

**Sold Individual*

Spindle Taper Wipers

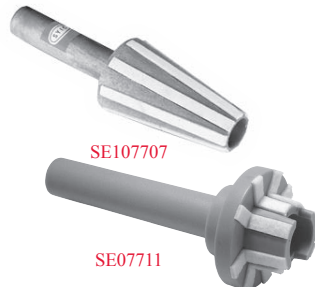

Part Number	Taper	Length	Taper Length	Handle Diameter	Taper Max. Diameter
SE07703	30	170	60	24	32
SE07704	40	188	78	24	45
SE07705	50	240	120	30	70
NEW SE07710	HSK63A	165	31	22	n/a
SE07711	HSK63F	165	31	22	n/a

Collet Brushes

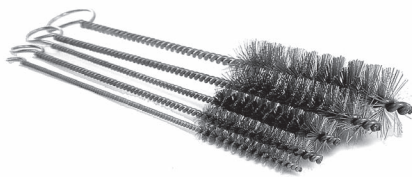

Part Number	Description
SECB250	1/4" Brush
SECB312	5/16" Brush
SECB375	3/8" Brush
SECB500	1/2" Brush
SECB625	5/8" Brush
SECB750	3/4" Brush
SECB1000	1" Brush
SECB-4KIT	1/4", 3/8", 1/2", 3/4" Brushes
SECB-7KIT	1/4", 5/16", 3/8", 1/2", 5/8", 3/4", 1" Brushes

Torque Wrench



Torque Wrench

Part Number	Description	Range of Torque	Length	Spigot
NEW SE60TH	Torque Wrench	5-45 ft/lbs	12"	16mm Round
SE200TH	Torque Wrench	30-150 ft/lbs	16.5"	16mm Round
SE300TH	Torque Wrench	45-228 ft/lbs	21.5"	16mm Round

Torque Wrench Accessories



FOR BT, CAT, ISO AND HSK TOOL HOLDERS

Part Number	Collet Nut Size	Wrench Type	Maximum Torque
SESD-20mm-TWA	Fits all Old Style SD Collet Nuts	Hook	
SESD-C001-TWA	Fits Piggy Back Style Collet Nuts	Hook	
SESD-C015-TWA	Fits New Style SD Collet Nuts	Hook	
SESS22TWA	Fits all SS-22 Collet Nuts	Hex	50 ft/lbs
SESS22EXTTWA	Fits all SS-22 Extended Nuts	Hex	50 ft/lbs
SE04580-16	ER 16	Slotted	50 ft/lbs
SE04601-16	ER 16 Hex	Hex	50 ft/lbs
SE04580-20	ER 20	Slotted	75 ft/lbs
SE04602-20	ER 20 Hex	Hex	75 ft/lbs
SE04603-25	ER 25 Slotted	Slotted	95 ft/lbs
NEW SE04576	ER 11 Mini	Mini	14 ft/lbs
NEW SE04577	ER 16 Mini	Mini	22 ft/lbs
NEW SE04578	ER 20 Mini	Mini	25 ft/lbs
SE04587	ER 25 M	Mini	45 ft/lbs
SE04604-32	ER 32 Slotted	Slotted	125 ft/lbs
SE04605-40	ER 40 Slotted	Slotted	140 ft/lbs
SE03690-25	SYOZ 25/TG 100	Hook	100 ft/lbs
NEW SE04018-TWA	TG 75 Slotted	Hook	100 ft/lbs
NEW SE04588-R	ER 32 Slotted	Slotted	125 ft/lbs

RETENTION KNOB SOCKETS

Part Number	Taper or Holder	Wrench Flats	Square Drive	Maximum Torque
SEPSS-30BT	BT 30 Taper Pull Studs	0.535"	1/4"	40 ft/lbs
SEPSS-30ISO	ISO 30 Taper Pull Studs	0.535"	3/8"	40 ft/lbs
NEW SEPSS-40	BT 30 Taper Pull Studs	0.750"	3/8"	85 ft/lbs
NEW SEPSS-50	BT 50 Taper Pull Studs	1.187"	1/2"	110 ft/lbs
NEW SEPSSC-50	CAT 50 Taper Pull Studs	1.250"	1/2"	110 ft/lbs

FIXED HEAD SQUARE DRIVES

Part Number	Description	Square Drive
SE29828	3/8" Square Drive	3/8" Drive
SE29827	1/2" Square Drive	1/2" Drive

Toolholder Measuring Guide – Special

USE THIS GUIDE FOR MEASURING YOUR TOOLS TO DETERMINE WHAT YOU NEED TO RE-ORDER, OR FOR SPECIAL ORDER TOOLHOLDERS BUILT TO YOUR SPECIFICATIONS.

Make & model of CNC router _____

Pull Stud dimensions

P= _____

A= _____

L= _____

R= _____

Toolholder Dimensions

D= _____

F= _____

W= _____

A= _____

N= _____

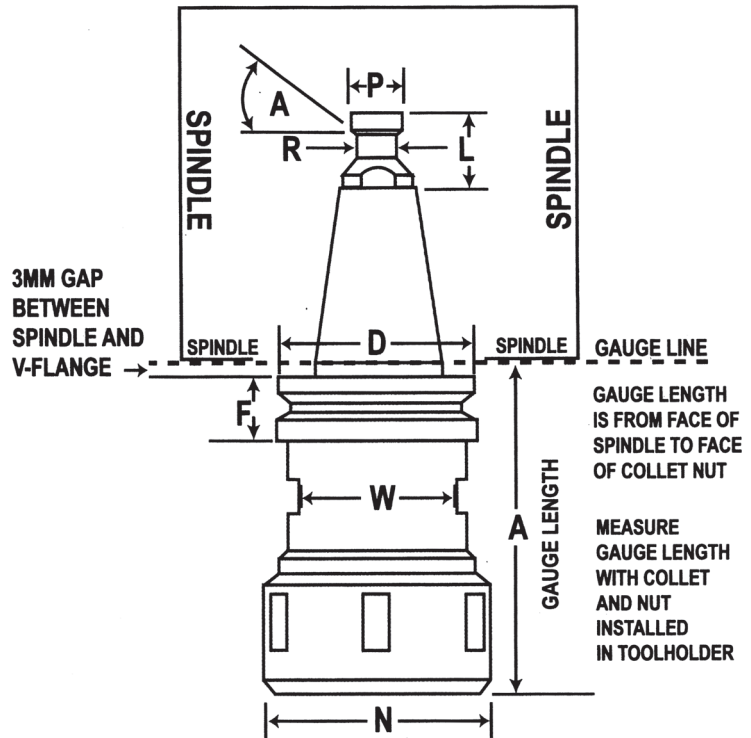

Make & model of HSK spindle CNC router _____

Toolholder Dimensions

D= _____

F= _____

W= _____

A= _____

N= _____

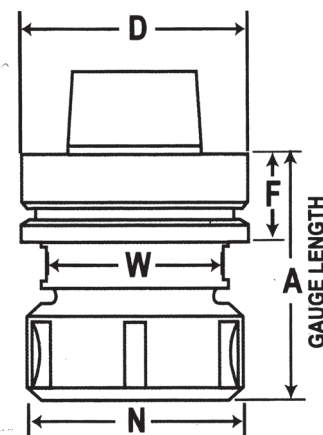

1

2

3

4

5

6

7

8

9

10

Aggregate Heads

Below are just some examples of the many possible heads. Due to the complexity of Aggregate heads and the additional information that we must have to get you an accurate quote, please call for pricing or to request more information.

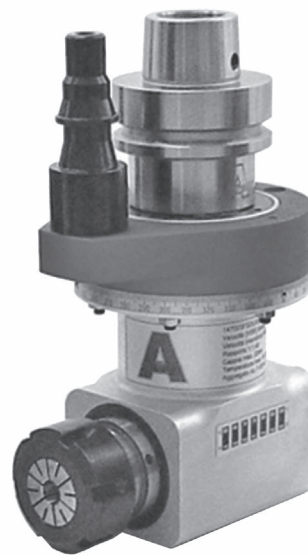
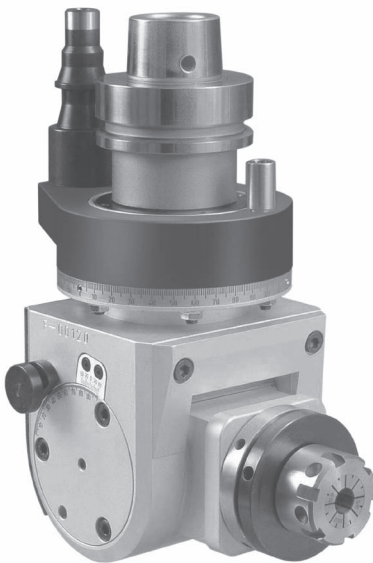
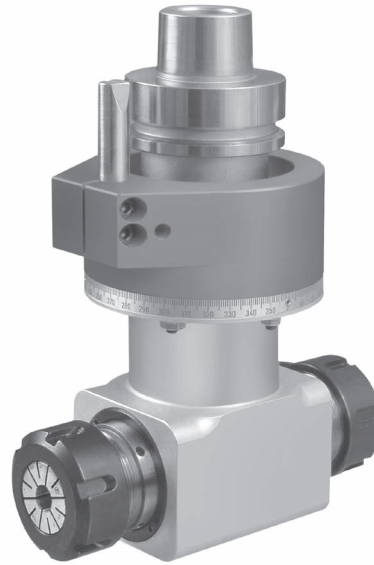
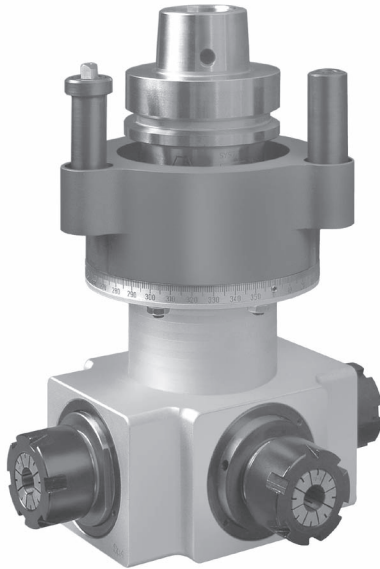

Carbide-Tipped Metric Boring Bits

BRAD POINT • 57MM OAL

NEW	Part Number		Diameter		Shank
	RH	LH	Brad Point 57 OAL	OAL	
	SE5703RH	SE5703LH	3mm	57mm	10mm
	SE5704RH	SE5704LH	4mm	57mm	10mm
	SE57045RH	SE57045LH	4.5mm	57mm	10mm
	SE57187RH	SE57187LH	4.76mm (3/16")	57mm	10mm
	SE5705RH	SE5705LH	5mm	57mm	10mm
	SE57051RH	SE57051LH	5.1mm	57mm	10mm
	SE57055RH	SE57055LH	5.5mm	57mm	10mm
	SE5706RH	SE5706LH	6mm	57mm	10mm
	SE57250RH	SE57250LH	6.35mm (1/4")	57mm	10mm
	SE57065RH	SE57065LH	6.5mm	57mm	10mm
	SE57067RH	SE57067LH	6.7mm	57mm	10mm
	SE5707RH	SE5707LH	7mm	57mm	10mm
	SE57075RH	SE57075LH	7.5mm	57mm	10mm
	SE5708RH	SE5708LH	8mm	57mm	10mm
	SE57082RH	SE57082LH	8.2mm	57mm	10mm
	SE57085RH	SE57085LH	8.5mm	57mm	10mm
	SE5709RH	SE5709LH	9mm	57mm	10mm
	SE57375RH	SE57375LH	9.52mm (3/8")	57mm	10mm
	SE5710RH	SE5710LH	10mm	57mm	10mm
	SE5711RH	SE5711LH	11mm	57mm	10mm
	SE57438RH	SE57438LH	11.1mm (7/16")	57mm	10mm
	SE5712RH	SE5712LH	12mm	57mm	10mm
	SE57500RH	SE57500LH	12.7mm (1/2")	57mm	10mm
	SE5713RH	SE5713LH	13mm	57mm	10mm
	SE5714RH	SE5714LH	14mm	57mm	10mm
	SE5715RH	SE5715LH	15mm	57mm	10mm
	SE57625RH	SE57625LH	15.9mm (5/8")	57mm	10mm
	SE5716RH	SE5716LH	16mm	57mm	10mm
	SE5717RH	SE5717LH	17mm	57mm	10mm
	SE5718RH	SE5718LH	18mm	57mm	10mm
	SE5719RH	SE5719LH	19mm	57mm	10mm
	SE5720RH	SE5720LH	20mm	57mm	10mm

BRAD POINT • 70MM OAL

NEW	Part Number		Diameter		Shank
	RH	LH	Brad Point 70 OAL	OAL	
	SE7003RH	SE7003LH	3mm	70mm	10mm
	SE7004RH	SE7004LH	4mm	70mm	10mm
	SE70045RH	SE70045LH	4.5mm	70mm	10mm
	SE70187RH	SE70187LH	4.76mm (3/16")	70mm	10mm
	SE7005RH	SE7005LH	5mm	70mm	10mm
	SE70051RH	SE70051LH	5.1mm	70mm	10mm
	SE70055RH	SE70055LH	5.5mm (7/32")	70mm	10mm
	SE7006RH	SE7006LH	6mm	70mm	10mm
	SE70250RH	SE70250LH	6.35mm (1/4")	70mm	10mm
	SE70065RH	SE70065LH	6.5mm	70mm	10mm
	SE70067RH	SE70067LH	6.7mm	70mm	10mm
	SE7007RH	SE7007LH	7mm	70mm	10mm
	SE70071RH	SE70071LH	7.1mm	70mm	10mm
	SE70075RH	SE70075LH	7.5mm	70mm	10mm
	SE7008RH	SE7008LH	8mm	70mm	10mm
	SE70082RH	SE70082LH	8.2mm	70mm	10mm
	SE70085RH	SE70085LH	8.5mm	70mm	10mm
	SE7009RH	SE7009LH	9mm	70mm	10mm
	SE70375RH	SE70375LH	9.52mm (3/8")	70mm	10mm

- CONTINUED ON NEXT PAGE

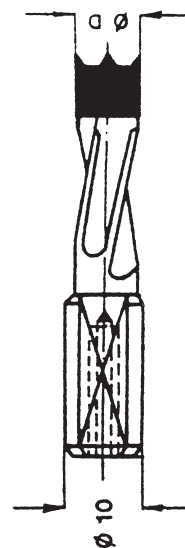
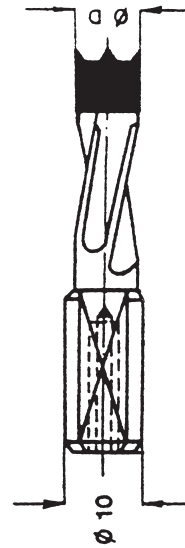

1

2

3

4

5

6

7

8

9

10

Carbide-Tipped Metric Boring Bits

BRAD POINT • 70MM OAL- CONTINUED

Part Number	Diameter	OAL	Shank
RH	LH	Brad Point 70 OAL	
SE7010RH	SE7010LH	10mm	10mm
SE70104RH	SE70104LH	10.4mm	10mm
SE7011RH	SE7011LH	11mm	10mm
SE70438RH	SE70438LH	11.1mm (7/16")	10mm
SE7012RH	SE7012LH	12mm	10mm
SE70500RH	SE70500LH	12.7mm (1/2")	10mm
SE7013RH	SE7013LH	13mm	10mm
SE7014RH	SE7014LH	14mm	10mm
SE70562RH	SE70562LH	14.27mm (9/16")	10mm
SE7015RH	SE7015LH	15mm	10mm
SE70625RH	SE70625LH	15.9mm (5/8")	10mm
SE7016RH	SE7016LH	16mm	10mm
NEW SE70165RH	SE70165LH	16.5mm	10mm
SE7017RH	SE7017LH	17mm	10mm
SE7018RH	SE7018LH	18mm	10mm
SE7019RH	SE7019LH	19mm	10mm
SE7020RH	SE7020LH	20mm	10mm
SE7025RH	SE7025LH	25mm	10mm

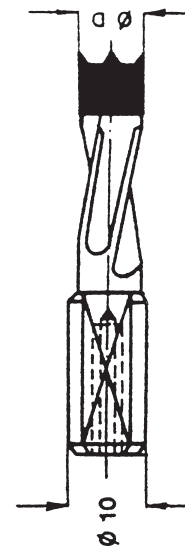

BRAD POINT • 77MM OAL

Part Number	Diameter	OAL	Shank
RH	LH	Brad Point 77 OAL	
SE7704RH	SE7704LH	4mm	77mm
SE7705RH	SE7705LH	5mm	77mm
SE7706RH	SE7706LH	6mm	77mm
NEW SE77250RH	SE77250LH	6.35mm (1/4")	77mm
SE7707RH	SE7707LH	7mm	77mm
SE7708RH	SE7708LH	8mm	77mm
NEW SE77375RH	SE77375LH	9.52mm (3/8")	77mm
SE7710RH	SE7710LH	10mm	77mm
NEW SE77438RH	SE77438LH	11.1mm (7/16")	77mm
SE7712RH	SE7712LH	12mm	77mm

BRAD POINT • 63.5MM OAL • 1/4" SHANK

Part Number	Diameter	OAL	Shank
RH	LH	Brad Point 63.5 OAL	
SE63505RH	SE63505LH	5mm	63.5mm (2 1/2")
SE635250RH	SE635250LH	6.35mm (1/4")	63.5mm (2 1/2")

V-POINT • 58MM OAL

Part Number	Diameter	OAL	Shank
RH	LH	V-Point 58 OAL	
NEW SEV5803RH	SEV5803LH	3mm	58mm
SEV5804RH	SEV5804LH	4mm	58mm
SEV58187RH	SEV58187LH	4.76mm (3/16")	58mm
SEV5805RH	SEV5805LH	5mm	58mm
SEV58055RH	SEV58055LH	5.5mm (7/32")	58mm
SEV5806RH	SEV5806LH	6mm	58mm
SEV58250RH	SEV58250LH	6.35mm (1/4")	58mm
SEV58065RH	SEV58065LH	6.5mm	58mm
SEV5807RH	SEV5807LH	7mm	58mm
SEV58079RH	SEV58079LH	7.9mm	58mm
SEV5808RH	SEV5808LH	8mm	58mm
SEV5809RH	SEV5809LH	9mm	58mm
SEV58375RH	SEV58375LH	9.52mm (3/8")	58mm
SEV5810RH	SEV5810LH	10mm	58mm
SEV5811RH	SEV5811LH	11mm	58mm
SEV58111RH	SEV58111LH	11.1mm (7/16")	58mm
SEV5812RH	SEV5812LH	12mm	58mm
SEV58500RH	SEV58500LH	12.7mm (1/2")	58mm

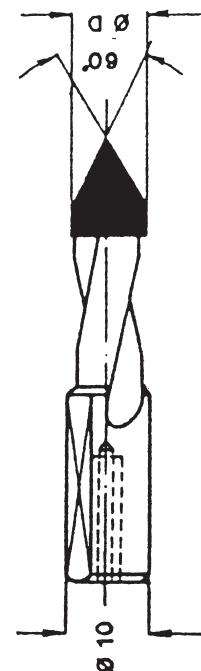

- CONTINUED ON NEXT PAGE

Carbide-Tipped Metric Boring Bits

V-POINT • 58MM OAL- CONTINUED

Part Number		Diameter		Shank
RH	LH	Brad Point 70 OAL	OAL	
SEV5813RH	SEV5813LH	13mm	58mm	10mm
SEV5814RH	SEV5814LH	14mm	58mm	10mm
SEV5815RH	SEV5815LH	15mm	58mm	10mm
SEV5816RH	SEV5816LH	16mm	58mm	10mm
SEV5818RH	SEV5818LH	18mm	58mm	10mm

V POINT • 70MM OAL

Part Number		Diameter		Shank
RH	LH	Thru V Point 70 OAL	OAL	
NEW SEV7003RH	SEV7003LH	3mm	70mm	10mm
SEV7004RH	SEV7004LH	4mm	70mm	10mm
SEV70187RH	SEV70187LH	4.76mm (3/16")	70mm	10mm
SEV7005RH	SEV7005LH	5mm	70mm	10mm
SEV70055RH	SEV70055LH	5.5mm (7/32")	70mm	10mm
SEV7006RH	SEV7006LH	6mm	70mm	10mm
SEV70250RH	SEV70250LH	6.35mm (1/4")	70mm	10mm
SEV70065RH	SEV70065LH	6.5mm	70mm	10mm
SEV7007RH	SEV7007LH	7mm	70mm	10mm
NEW SEV70071RH	SEV70071LH	7.1mm	70mm	10mm
SEV7008RH	SEV7008LH	8mm	70mm	10mm
SEV70082RH	SEV70082LH	8.2mm	70mm	10mm
SEV7009RH	SEV7009LH	9mm	70mm	10mm
SEV70375RH	SEV70375LH	9.52mm (3/8")	70mm	10mm
SEV7010RH	SEV7010LH	10mm	70mm	10mm
SEV70102RH	SEV70102LH	10.2mm	70mm	10mm
SEV70104RH	SEV70104LH	10.4mm	70mm	10mm
SEV7011RH	SEV7011LH	11mm	70mm	10mm
SEV70111RH	SEV70111LH	11.1mm (7/16")	70mm	10mm
SEV7012RH	SEV7012LH	12mm	70mm	10mm
SEV70500RH	SEV70500LH	12.7mm (1/2")	70mm	10mm
SEV7013RH	SEV7013LH	13mm	70mm	10mm
SEV7014RH	SEV7014LH	14mm	70mm	10mm
SEV70142RH	SEV70142LH	14.2mm (9/16")	70mm	10mm
SEV7015RH	SEV7015LH	15mm	70mm	10mm
SEV7016RH	SEV7016LH	16mm	70mm	10mm
NEW SEV7017RH	SEV7017LH	17mm	70mm	10mm
SEV7018RH	SEV7018LH	18mm	70mm	10mm
SEV7019RH	SEV7019LH	19mm	70mm	10mm

V POINT • 77MM OAL

Part Number		Diameter		Shank
RH	LH	Thru V Point 77 OAL	OAL	
SEV7704RH	SEV7704LH	4mm	77mm	10mm
SEV7705RH	SEV7705LH	5mm	77mm	10mm
SEV7706RH	SEV7706LH	6mm	77mm	10mm
SEV7707RH	SEV7707LH	7mm	77mm	10mm
SEV7708RH	SEV7708LH	8mm	77mm	10mm
SEV7710RH	SEV7710LH	10mm	77mm	10mm
NEW SEV77438RH	SEV77438LH	11.1mm (7/16")	77mm	10mm
SEV7712RH	SEV7712LH	12mm	77mm	10mm

HINGE BITS • 57MM OAL

Part Number		Diameter		Shank
RH	LH	Hinge Bits 57 OAL	OAL	
SEHB5715RH	SEHB5715LH	15mm	57mm	10mm
SEHB5716RH	SEHB5716LH	16mm	57mm	10mm
SEHB5717RH	SEHB5717LH	17mm	57mm	10mm
SEHB5718RH	SEHB5718LH	18mm	57mm	10mm
SEHB5719RH	SEHB5719LH	19mm	57mm	10mm

- CONTINUED ON NEXT PAGE

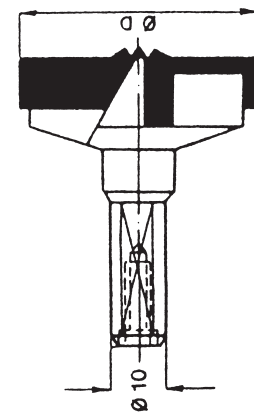
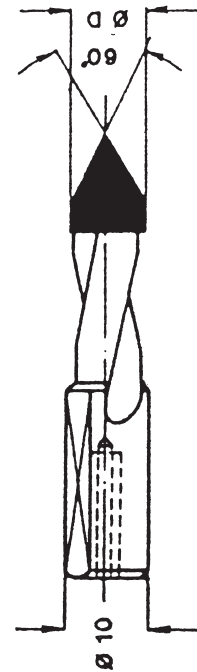

- 1
- 2
- 3
- 4
- 5
- 6
- 7
- 8
- 9
- 10

Carbide-Tipped Metric Boring Bits

HINGE BITS • 57MM OAL—CONTINUED

Part Number		Diameter		Shank
RH	LH	Hinge Bits 57 OAL	OAL	
SEHB5720RH	SEHB5720LH	20mm	57mm	10mm
SEHB5722RH	SEHB5722LH	22mm	57mm	10mm
SEHB5724RH	SEHB5724LH	24mm	57mm	10mm
SEHB5725RH	SEHB5725LH	25mm	57mm	10mm
SEHB5726RH	SEHB5726LH	26mm	57mm	10mm
SEHB5728RH	SEHB5728LH	28mm	57mm	10mm
SEHB5730RH	SEHB5730LH	30mm	57mm	10mm
SEHB5732RH	SEHB5732LH	32mm	57mm	10mm
SEHB5734RH	SEHB5734LH	34mm	57mm	10mm
SEHB5735RH	SEHB5735LH	35mm	57mm	10mm
SEHB5736RH	SEHB5736LH	36mm	57mm	10mm
SEHB5738RH	SEHB5738LH	38mm	57mm	10mm
SEHB5740RH	SEHB5740LH	40mm	57mm	10mm

HINGE BITS • 70MM OAL

Part Number		Diameter		Shank
RH	LH	Hinge Bits 70 OAL	OAL	
SEHB7015RH	SEHB7015LH	15mm	70mm	10mm
SEHB7016RH	SEHB7016LH	16mm	70mm	10mm
SEHB70165RH	SEHB70165LH	16.5mm	70mm	10mm
SEHB7017RH	SEHB7017LH	17mm	70mm	10mm
SEHB7018RH	SEHB7018LH	18mm	70mm	10mm
SEHB7019RH	SEHB7019LH	19mm	70mm	10mm
SEHB7020RH	SEHB7020LH	20mm	70mm	10mm
SEHB7022RH	SEHB7022LH	22mm	70mm	10mm
SEHB7024RH	SEHB7024LH	24mm	70mm	10mm
SEHB7025RH	SEHB7025LH	25mm	70mm	10mm
SEHB7026RH	SEHB7026LH	26mm	70mm	10mm
SEHB7028RH	SEHB7028LH	28mm	70mm	10mm
SEHB7030RH	SEHB7030LH	30mm	70mm	10mm
SEHB7032RH	SEHB7032LH	32mm	70mm	10mm
SEHB7034RH	SEHB7034LH	34mm	70mm	10mm
SEHB7035RH	SEHB7035LH	35mm	70mm	10mm
SEHB7036RH	SEHB7036LH	36mm	70mm	10mm
SEHB7038RH	SEHB7038LH	38mm	70mm	10mm
SEHB7040RH	SEHB7040LH	40mm	70mm	10mm

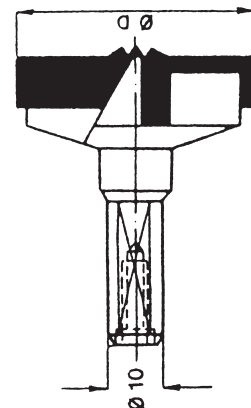

Solid Carbide Drills

Adapters on Top of Next Page

Part Number		Diameter		Shank
RH	LH		OAL	
Center Drills • Drill Point				
CD4502RH	CD4502LH	2mm	45mm	2mm
CD53025RH	CD53025LH	2.5mm	53mm	2.5mm
NEW CD53028RH	CD53028LH	2.8mm	53mm	2.8mm
Brad Points				
BPD5303RH	BPD5303LH	3mm	53mm	3mm
BPD53032RH	BPD53032LH	3.2mm	53mm	3.2mm
BPD53035RH	BPD53035LH	3.5mm	53mm	3.5mm
BPD5304RH	BPD5304LH	4mm	53mm	4mm
BPD53045RH	BPD53045LH	4.5mm	53mm	4.5mm
BPD5305RH	BPD5305LH	5mm	53mm	5mm

Drill Adapters

For Solid Carbide Drills on Previous Page

Part Number	d Drill Hole Size	D Diameter	L Length	S Shank
DA3502	2mm	15mm	35mm	10mm
DA35025	2.5mm	15mm	35mm	10mm
NEW DA35028	2.8mm	15mm	35mm	10mm
DA3503	3mm	15mm	35mm	10mm
DA35032	3.2mm	15mm	35mm	10mm
DA35035	3.5mm	15mm	35mm	10mm
DA3504	4mm	15mm	35mm	10mm
DA35045	4.5mm	15mm	35mm	10mm
DA3505	5mm	15mm	35mm	10mm
DACSP screw	Replacement Screw			

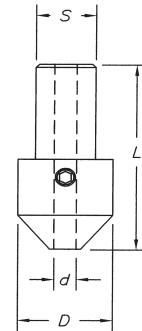

Solid Carbide Boring Bits with Steel Shank

Part Number		Brad Points		Shank Diameter	L
RH	LH	D Diameter	B Twist Length	10mm x 27mm	OAL
SCBP5703RH	SCBP5703LH	3mm	18mm	10mm	57mm
SCBP5704RH	SCBP5704LH	4mm	20mm	10mm	57mm
SCBP5705RH	SCBP5705LH	5mm	20mm	10mm	57mm
SCBP5706RH	SCBP5706LH	6mm	20mm	10mm	57mm
SCBP5708RH	SCBP5708LH	8mm	20mm	10mm	57mm
SCBP7003RH	SCBP7003LH	3mm	28mm	10mm	70mm
SCBP7004RH	SCBP7004LH	4mm	30mm	10mm	70mm
SCBP7005RH	SCBP7005LH	5mm	30mm	10mm	70mm
SCBP7006RH	SCBP7006LH	6mm	30mm	10mm	70mm
SCBP7008RH	SCBP7008LH	8mm	30mm	10mm	70mm
NEW SCBP7010RH	SCBP7010LH	10mm	30mm	10mm	70mm

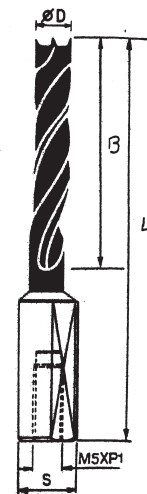

Part Number		V-Points		Shank Diameter	L
RH	LH	D Diameter	B Twist Length	10mm x 27mm	OAL
SCVP5805RH	SCVP5805LH	5mm	20mm	10mm	58mm
SCVP5808RH	SCVP5808LH	8mm	20mm	10mm	58mm
SCVP7005RH	SCVP7005LH	5mm	20mm	10mm	70mm
SCVP7008RH	SCVP7008LH	8mm	20mm	10mm	70mm

Carbide-Tipped Threaded Shank Dowel

Part Number		Diameter	Shank Thread	OAL
RH	LH			
SETSM8005RH	SETSM8005LH	5mm	M8 x 1.25	100mm
SETSM8006RH	SETSM8006LH	6mm	M8 x 1.25	100mm
SETSM8008RH	SETSM8008LH	8mm	M8 x 1.25	100mm
SETSM8010RH	SETSM8010LH	10mm	M8 x 1.25	100mm
SETSM8012RH	SETSM8012LH	12mm	M8 x 1.25	100mm
SETSM8015RH	SETSM8015LH	15mm	M8 x 1.25	100mm
SETSM1005RH	SETSM1005LH	5mm	M10 x 1.25	100mm
SETSM1006RH	SETSM1006LH	6mm	M10 x 1.25	100mm
SETSM1008RH	SETSM1008LH	8mm	M10 x 1.25	100mm
SETSM1010RH	SETSM1010LH	10mm	M10 x 1.25	100mm
SETSM1012RH	SETSM1012LH	12mm	M10 x 1.25	100mm
SETSM1015RH	SETSM1015LH	15mm	M10 x 1.25	100mm

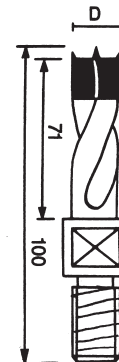

Chuck Adapters with Threaded Shank

1

Part Number		Shank Threads	Machine(s)
RH	LH		
QCDA1001RH	QCDA1002LH	M10	Ayen, Mayer, Torwegge

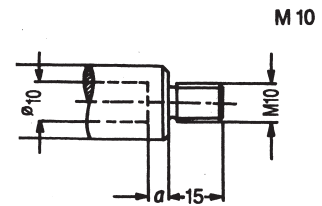

2

Part Number		Shank Threads	Machine(s)
RH	LH		
QCDA1003RH	QCDA1004LH	M10	Morbidelli, Weeke, Holtzer SCMI, Reimall, Vitap

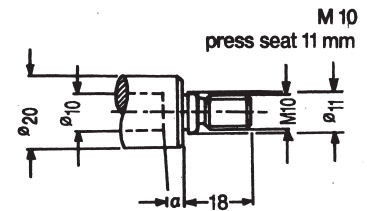

3

Part Number		Shank Threads	Machine(s)
RH	LH		
QCDA1005RH	QCDA1006LH	M10	Busselatto, Ompec Bilek, Weeke

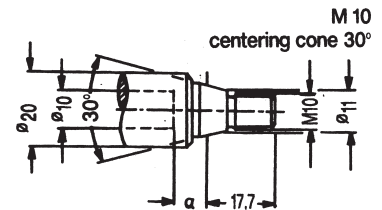

5

Part Number		Shank Threads	Machine(s)
RH	LH		
QCDA8001RH	QCDA8002LH	M8	Nottmeyer

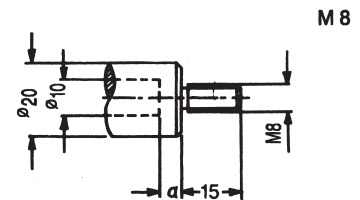

6

Part Number		Shank Threads	Machine(s)
RH	LH		
QCDA8003RH	QCDA8004LH	M8	Nottmeyer, Morbidelli

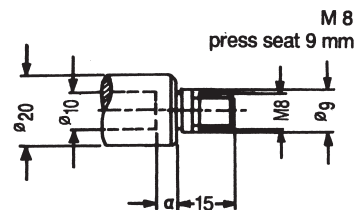

7

Part Number		Shank Threads	Machine(s)
RH	LH		
QCDA8005RH	QCDA8006LH	M8	Bilek

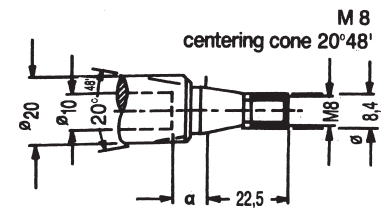

8

QUICK CHANGE ADAPTER - BIESSE

Part Number	Description
QCDA-Biesse	10 x 20 x 3
QCDA-screw	screw for adapter
QCDA-Morbideli	FM400

QCDA-Biesse

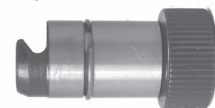

QCDA-Morbideli

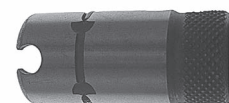

10

NEW

Carbide-Tipped Countersink Bits

Carbide-Tipped Countersinks

For clamping on the Spiral of the Brad Point or V Point Drill

Part Number		Diameter	Size
RH	LH		
CSP1604RH	CSP1604LH	16mm	4mm
CSP1605RH	CSP1605LH	16mm	5mm
CSP1606RH	CSP1606LH	16mm	6mm
CSP16250RH	CSP16250LH	16mm	6.35mm (1/4")
CSP1607RH	CSP1607LH	16mm	7mm
CSP1808RH	CSP1808LH	18mm	8mm
CSP1809RH	CSP1809LH	18mm	9mm
CSP2010RH	CSP2010LH	20mm	10mm
CSP2012RH	CSP2012LH	20mm	12mm

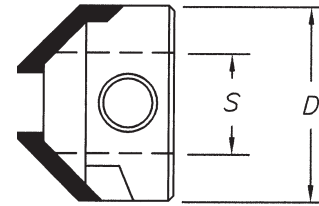

Replacement screw for the countersink above.
Part # DACSP screw

Carbide-Tipped Countersinks

For clamping on the Shank of the Brad Point or V Point Drill

Part Number		For Sizes	Size
RH	LH		
CSH20510RH	CSH20510LH	5mm to 10mm	5mm to 10mm
CSH201112RH	CSH201112LH	11mm to 12mm	11mm to 12mm

Carbide-Tipped Countersinks Adjustable 45 Degree Angle

Part Number	Description	For Screw
SE918	3/8" x 1/8"	# 4
SE921	3/8" x 9/46"	# 6
SE924	3/8" x 5/32"	# 8
SE927	3/8" x 11/64"	# 8-9
SE930	3/8" x 3/16"	# 10

Uses SFFB-SCREW



SE918

Carbide-Tipped Counterbores

DRILL NOT INCLUDED — MUST ORDER BELOW

Part Number		Description	Shank	Overall Length
LH	RH			
SE940	SE942	3/8 CD Bit	10mm	2 3/8"
SE944	SE946	3/16 Drill	3/16	2 1/4"



Quick Change Adapter For Metric Drills

Part Number	Shank	OAL
QCHDA250	1/4" Hex	1 3/4"



QCHDA250

Carbide-Tipped Metric Bits

COUNTERBORE & COUNTERSINK • ONE PIECE DESIGN

Southeast Tool can help with all of your specialty or custom tooling needs. Just determine your lengths, diameters and angles and we can provide the exact tool you need to do the job right! Here are a few examples:

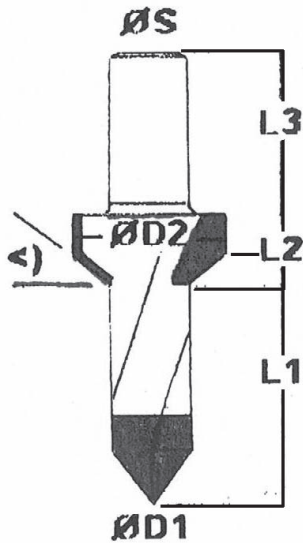

**COUNTERSINK WITH
V-POINT**

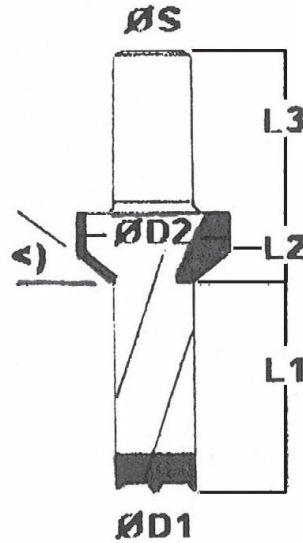

**COUNTERSINK WITH
BRAD POINT**

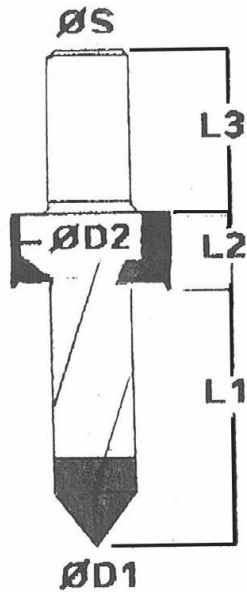

**COUNTERBORE WITH
V-POINT**

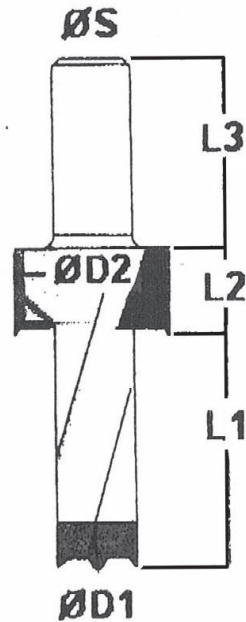

**COUNTERBORE WITH
BRAD POINT**

Insert Router Bits

2 FLUTE FLUSH TRIM INSERT BITS



Insert Bit Bearing

Part Number	Diameter	Cut Length	Shank	OAL	Insert
SEIFT-71214	3/4"	12mm	1/4"	2-1/4"	SI-121215
SEIFT-71212	3/4"	12mm	1/2"	2-1/2"	SI-121215
SEIFT-73012	3/4"	30mm	1/2"	3-3/16"	SI-301215
SEIFT-74012	3/4"	40mm	1/2"	3-5/8"	SI-401215
SEIFT-75012	3/4"	50mm	1/2"	3-15/16"	SI-501217

Use SI4-Screw

Use SBE119 Bearing

1 FLUTE INSERT STRAIGHT BITS



Insert Bit 1 Flute

Part Number	Diameter	Cut Length	Shank	OAL	Insert
SEIS1-73012	3/4"	30mm	1/2"	3-3/8"	SI-2951215
SEIS1-74012	3/4"	40mm	1/2"	3-3/8"	SI-3951215

Use SI35-Screw

2 FLUTE INSERT STRAIGHT BITS



Insert Bit



SEINS-34

Part Number Inserts	Cutting Diameter	Cutting Length	Shank Diameter	Overall Length	Insert
SEINS-34	3/4"	30mm	3/4"	3"	SI-2951215
SEINS-34-12	3/4"	30mm	1/2"	3"	SI-301215
SEIS2-740	3/4"	40mm	1/2"	3-5/16"	SI-401215
SEIS2-750	3/4"	50mm	1/2"	3-11/16"	SI-501217
SEINS-34-58	3/4"	30mm	5/8"	3"	SI-2951215
SEINS-34-40	3/4"	40mm	3/4"	4"	SI-3951215
SEINS-34-50	3/4"	50mm	3/4"	4-1/4"	SI-4951215
SEINS-1-30	1"	30mm	1/2"	3"	SI-2951215

Use SICS-Screw

Use SI4-Screw

Four Sided Inserts for End Cutting

2 FLUTE INSERT TEMPLATE BITS • 1/2" SHANK



SEIT75030

Part Number	Cutting Diameter	Cutting Length	OAL	Bearing	Inserts
SEIT750-30	3/4"	30mm	3"	SBE155	SI-2951215
SEIT750-40	3/4"	40mm	3-5/16"	SBE155	SI-3951215
SEIT750-50	3/4"	50mm	3 -1/16"	SBE155	SI-501217
SEIT1125-30	1-1/8"	30mm	3"	SBE150	SI-2951215
SEIT1125-40	1-1/8"	40mm	3-5/16"	SBE150	SI-3951215
SEIT1125-50	1-1/8"	50mm	3-11/16"	SBE150	SI-4951215

Use SI4-Screw

Use SELC-1/2 Collar

Four Sided Inserts for End Cutting

1 FLUTE V-GROOVE BIT • 1/2" SHANK



SEIV91-12

Part Number	Cutting Diameter	Cutting Length	Angle	Shank	OAL	Insert
SEIV90-12	25mm	15.5mm	90°	1/2"	2-5/8"	SIV151215
SEIV91-12	18mm	12mm	91°	1/2"	2-5/16"	SI-121215

Use SI4-Screw

1

2

3

4

5

6

7

8

9

10

Insert Router Bits

1



22 DEGREE BEVEL BITS • 2 FLUTE

Part Number	Small Diameter	Cut Length	Angle	Shank	OAL	Insert
SEIBT22-14	3/4"	12mm	22°	1/4"	2-1/8"	SI-121215
SEIBT22-12	3/4"	12mm	22°	1/2"	2-1/4"	SI-121215

Use S14-Screw

2

3



45 DEGREE BEVEL BITS • 2 FLUTE

Part Number	Small Diameter	Cut Length	Angle	Shank	OAL	Insert
SEIBT45-14	3/4"	12mm	45°	1/4"	2-1/8"	SI-121215
SEIBT45-12	3/4"	12mm	45°	1/2"	2-1/4"	SI-121215

Use S14-Screw

4

5



INSERT COMPRESSION BITS • 2+2

Part Number	Cutting Diameter	Cutting Length	Shank Diameter	Overall Length	Inserts
SEINS22-40	1-1/4"	40mm	3/4"	3-3/4"	SI-301215, SI-121215
SEINS22-50	1-1/4"	50mm	3/4"	4-1/2"	SI-501215, SI-121215

Use SICS-Screw

6

7

8



45 DEGREE INSERT BIT • 1 FLUTE

Part Number	Diameter	Cut Height	Shank
SECS143IR	50mm	1"	3/4"

Replacement Insert: Part # SECS143IR insert



9

10

Insert Spoilboard Surfacing Cutters

STRAIGHT (for MDF and Particleboard)

Part Number	Cutting Diameter	Cutting Length	Shank Diameter	# of Wings
NEW SPOIL178-2	1-7/8"	1/2"	1/2"	2
SPOIL25-2	2-1/2"	1/2"	1/2"	2
SPOIL4-2	4"	1/2"	3/4"	2
SPOIL4-3	4"	1/2"	3/4"	3

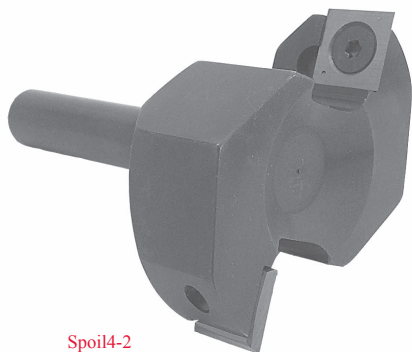

Spoil4-2

UP-SHEAR (for Balsa Core Material)

Part Number	Cutting Diameter	Cutting Length	Shank Diameter	# of Wings
SPOIL25-2UP	2-1/2"	1/2"	1/2"	2
SPOIL4-2UP	4"	1/2"	3/4"	2
SPOIL4-3UP	4"	1/2"	3/4"	3

Part Number	Description
SPOIL-Insert	(Replacement insert for spoilboard cutter 10 pc pack)
SPOIL-Screw	(Replacement screw for spoilboard cutter)
SPOIL-Wrench	(Wrench for spoilboard cutter insert)

Insert Tooling

2 WING COPE (STILE) & STICK (RAIL) BITS 3/4" Shank 3" Cut Diameter• Face Down



Face Down

Part Number	Description	Shank	Comments
SEIBCSFD	Cope (Stile)	3/4"	Face Down
SEIBSSFD	Stick (Rail)	3/4"	Face Down

The same body fits all three styles below.

Part Number	Description	Comments
SE-ICSOFD	Ogee Insert-Cope (Stile)	Face Down Sold each.
SE-IRSOFD	Ogee Insert-Stick (Rail)	Face Down Sold each.
SE-ICSBFD	Bead Insert-Cope (Stile)	Face Down Sold each.
SE-IRSBFD	Bead Insert-Stick (Rail)	Face Down Sold each.
SE-ICSRFD	Round Insert-Cope (Stile)	Face Down Sold each.
SE-IRSRFD	Round Insert-Stick (Rail)	Face Down Sold each.

1

2

3

4

5

6

7

8

9

10

Insert Tooling

2 WING COPE (STILE) & STICK (RAIL) BITS 3/4" Shank 3" Cut Diameter • Face Up

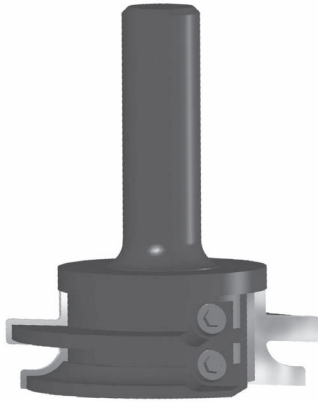

Face Down

Part Number	Description	Shank	Comments
SEIBCS	Cope (Stile)	3/4"	Face Up
SEIBSS	Stick (Rail)	3/4"	Face Up

The same body fits all three styles below.

Part Number	Description	Comments
SE-ICSO	Ogee Insert-Cope (Stile)	Face Up Sold each.
SE-IRSO	Ogee Insert-Stick (Rail)	Face Up Sold each.
SE-ICSB	Bead Insert-Cope (Stile)	Face Up Sold each.
SE-IRSB	Bead Insert-Stick (Rail)	Face Up Sold each.
SE-ICSR	Round Insert-Cope (Stile)	Face Up Sold each.
SE-IRSR	Round Insert-Stick (Rail)	Face Up Sold each.

2 WING RAISED PANEL BITS 3/4" Shank • Face Up



Raised Panel

Part Number	Description	Shank	Comments
SEIBRP-34	Raised Panel Body	3/4"	Face Up

The same body fits all three styles below.

Part Number	Description (Solid Carbide)	Comments
SE-IRPC	Round Raised Panel Insert	Face Up Sold each.
SE-IRPS	Straight Raised Panel Insert	Face Up Sold each.
SE-IRPO	Ogee Raised Panel Insert	Face Up Sold each.

Insert 3 Wing Cope and Stick Cutters

4" LG DIAMETER X 1-1/4" BORE X RH ROTATION - FACE DOWN

COPE (STILE)

Each body comes with one set of knives

Part Number	Description
SE-BCS	Insert Cope (Stile) Body
SE-ICSR	Round Cope (Stile) Profile Insert
SE-ICSB	Bead Cope (Stile) Profile Insert
SE-ICSO	Ogee Cope (Stile) Profile Insert

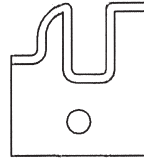

SE-ICSR

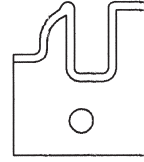

SE-ICSB

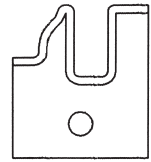

SE-ICSO

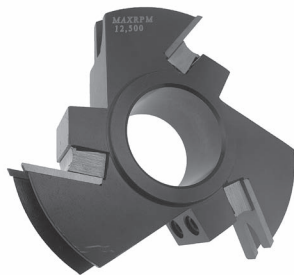

COPE



STICK



STICK (RAIL)

Each body comes with one set of knives

Part Number	Description
SE-BRS	Insert Rail (Stick) Body
SE-IRSR	Round Rail (Stick) Insert
SE-IRSB	Bead Rail (Stick) Insert
SE-IRSO	Ogee Rail (Stick) Insert

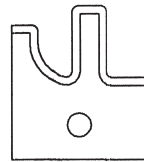

SE-IRSR

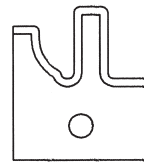

SE-IRSB

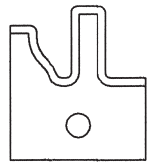

SE-IRSO

Insert 3 Wing Raised Panel Cutters

7-1/2" LG DIAMETER X 1-1/4" BORE - FACE DOWN

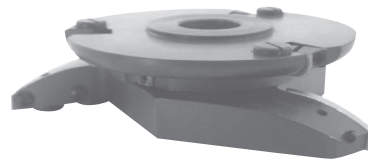

RAISED PANEL (with optional back cutter)

RAISED PANEL

Each body comes with one set of knives

Part Number	Description
SE-BRP	Insert Raised Panel Body
SE-IRPC	Round Raised Panel Insert
SE-IRPS	Straight Raised Panel Insert
SE-IRPO	Ogee Raised Panel Insert

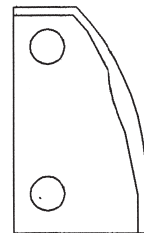

SE-IRPC

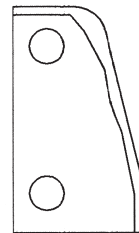

SE-IRPS

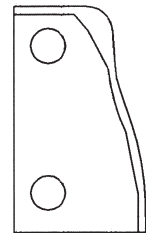

SE-IRPO

Note: Insert tooling requires your machine and spindle to be in good condition with minimum runout. The bushings should be in good condition also.

1

2

3

4

5

6

7

8

9

10

Insert 3 Wing Back Panel Cutter

5-3/4" LG DIAMETER X 1-1/4" BORE



Part Number	Description
SE-BBP	Insert Back Panel Body
SE-IBP	Back Panel Insert

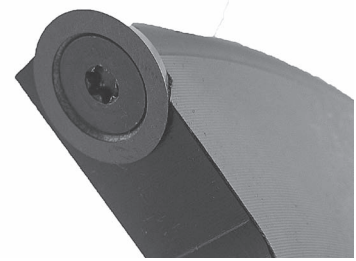

Insert 3 Wing Raised Panel Trim Cutter

4" LG DIAMETER X 1-1/4" BORE • USED TO TRIM END PANELS



Part Number	Description
SE-BRPT	Insert Raised Panel Trim Cutter
SE-IRPT	Trim Cutter Insert (7.5 x 12)

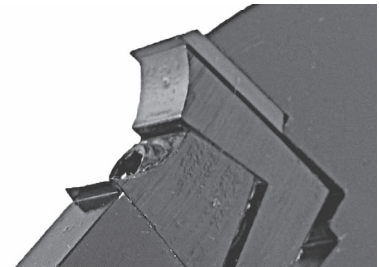

Accessories For 3 Wing Cutter Inserts

Part Number	Description
SE750TBU	3/4" T Type Bushing
SE1000TBU	1" T Type Bushing
RB41250	Rub Bearing 4" OD x 1-1/4" ID x 1/2" Thick

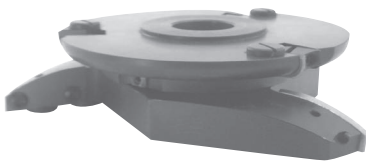

Raised Panel



Cope & Stick Cutters



Cope & Stick Cutters

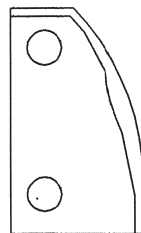

SE-IRPC

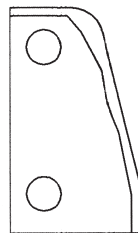

SE-IRPS

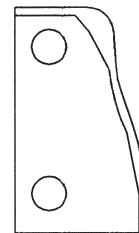

SE-IRPO

Note: Insert tooling requires your machine and spindle to be in good condition with minimum runout. The bushings should be in good condition also.

Standard Reversible Insert Knives

Part Number Description (L x W x T)

2 Sided 1 Hole

SI-751215	7.5 x 12 x 1.5
SI-861215	8.6 x 12 x 1.5
SI-901215	9.0 x 12 x 1.5
SI-961215	9.6 x 12 x 1.5
NEW SI-10510515	10.5 x 10.5 x 1.5
SI-131215	13 x 12 x 1.5
SI-151215	15 x 12 x 1.5
NEW SI-181215	18 x 12 x 1.5
SI-201215	20 x 12 x 1.5
SI-251215	25 x 12 x 1.5

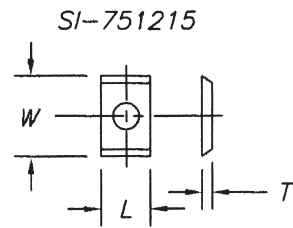

4 Sided 1 Hole

SI-121215	12 x 12 x 1.5
SI-131325	13 x 13 x 2.5
SI-1361362	13.6 x 13.6 x 2.0
SI-141412	14 x 14 x 1.2
SI-141420	14 x 14 x 2.0
NEW SI-141420-SP	14 x 14 x 2.0 T04F Grade
SI-141420CR	14 x 14 x 2.0 w/Corner Radius
SI-14314325	14.3 x 14.3 x 2.5
SI-14614625	14.6 x 14.6 x 2.5
NEW SI-14614625CR	14.6 x 14.6 x 2.5 w/Corner Radius
SI-151525	15 x 15 x 2.5 w/150mm Radius
SI-151525-R50	15 x 15 x 2.5 w/50mm Radius
SI-151525-SQ	15 x 15 x 2.5 w/Square Corners
NEW SI-151525-SQ-SP	15 x 15 x 2.5 w/Square Coners T08CR
NEW SI-151525 Byrd	15 x 15 x 2.5 w/100mm Radius
SI-1717203	17 x 17 x 2.0 w/3mm Hole
SI-1717204	17 x 17 x 2.0 w/4mm Hole
SI-1957015	19.5 x 7 x 1.5
SI-1957515	19.5 x 7.5 x 1.5
SI-1958015	19.5 x 8.0 x 1.5
SI-1959015	19.5 x 9.0 x 1.5
SI-1951015	19.5 x 10 x 1.5
SI-1951115	19.5 x 11 x 1.5
SI-1951215	19.5 x 12 x 1.5
SI-191920	19 x 19 x 2.0 W/4mm Hole
NEW SI-212155	21 x 21 x 5.5 x 40°

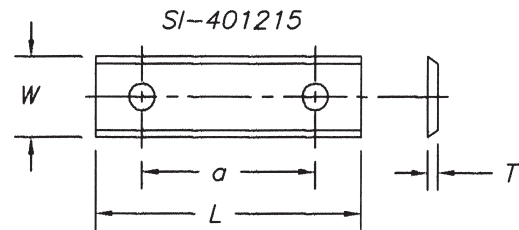
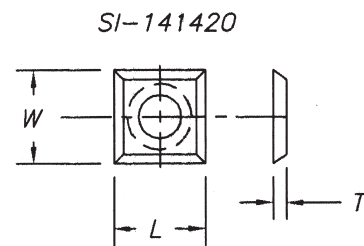
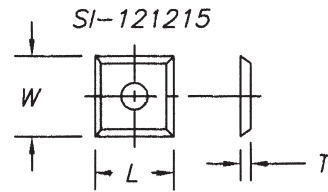

2 Sided 2 Holes

SI-251215-2	25 x 12 x 1.5 14 CTC
SI-301215	30 x 12 x 1.5 14 CTC
SI-301215-16	30 x 12 x 1.5 16 CTC
NEW SI-351215	35 x 12 x 1.5 26 CTC
SI-401215	40 x 12 x 1.5 26 CTC
SI-501215	50 x 12 x 1.5 26 CTC
SI-601215	60 x 12 x 1.5 26 CTC
SI-801322	80 x 13 x 2.2 60 CTC
SI-1001322	100 x 13 x 2.2 60 CTC
SI-1201322	120 x 13 x 2.2 60 CTC

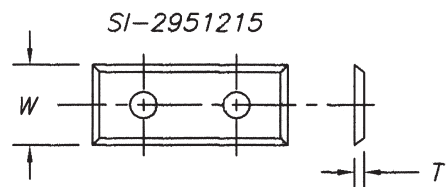

1

2

3

4

5

6

7

8

9

10

Standard Reversible Insert Knives

1

Part Number	Description (L x W x T)
4 Sided 2 Holes (14 CTC) Plunge	
NEW SI-287015	28 x 7.0 x 1.5
SI-2957015	29.5 x 7 x 1.5
SI-2957515	29.5 x 7.5 x 1.5
SI-2958015	29.5 x 8.0 x 1.5
SI-2959015	29.5 x 9.0 x 1.5
NEW SI-2959015SP	29.5 x 9.0 x 1.5 T03SMG Grade
SI-2951015	29.5 x 10 x 1.5
SI-2951115	29.5 x 11 x 1.5
SI-2951215	29.5 x 12 x 1.5
NEW SI-2951215SP	29.5 x 12 x 1.5 T03SMG Grade
SI-301215P	30 x 12 x 1.5
NEW SI-301215SP	30 x 12 x 1.5 T03SMG Grade
NEW SI-301215-TL15	30 x 12 x 1.5 TL15 Grade

2

3

4 Sided 2 Holes (26 CTC Plunge)

SI-3951215	39.5 x 12 x 1.5
SI-4958015	49.5 x 8 x 1.5
SI-4959015	49.5 x 9 x 1.5
NEW SI-4959015-SP	49.5 x 9 x 1.5 T03SMG Grade
SI-4951015	49.5 x 10 x 1.5
SI-4951115	49.5 x 11 x 1.5
SI-4951215	49.5 x 12 x 1.5
NEW SI-4951215-SP	49.5 x 12 x 1.5 T04F Grade
SI-5951215	59.5 x 12 x 1.5

4

5

4 Sided 3 Holes (37 CTC)

SI-501017	50 x 10 x 1.7
SI-501217	50 x 12 x 1.7

6

End Angle 1 Hole

SI-201215AL	20 x 12 x 1.5 Angle Left
SI-201215AR	20 x 12 x 1.5 Angle Right

End Angle 2 Holes (14 CTC)

SI-301215AL	30 x 12 x 1.5 Angle Left
SI-301215AR	30 x 12 x 1.5 Angle Right

7

End Angle 2 Holes (26 CTC)

SI-401215AL	40 x 12 x 1.5 Angle Left
SI-401215AR	40 x 12 x 1.5 Angle Right
SI-501215AL	50 x 12 x 1.5 Angle Left
SI-501215AR	50 x 12 x 1.5 Angle Right

8

Double Angle 2 Holes

SI-301215DCL	30 x 12 x 1.5 RB-TL	14CTC
SI-301215DCR	30 x 12 x 1.5 LB-TR	14CTC
SI-501215DCL	50 x 12 x 1.5 LB-TR	26CTC
SI-501215DCR	50 x 12 x 1.5 RB-TL	25CTC

9

2 Sided Back Groove

SI-125511BG	12 x 5.5 x 1.1 Back Groove
SI-205511BG	20 x 5.5 x 1.1 Back Groove
SI-305511BG	30 x 5.5 x 1.1 Back Groove
SI-405511BG	40 x 5.5 x 1.1 Back Groove
SI-505511BG	50 x 5.5 x 1.1 Back Groove
NEW SI-505511BG-T03	50 x 5.5 x 1.1 Back Groove T03SMG

10

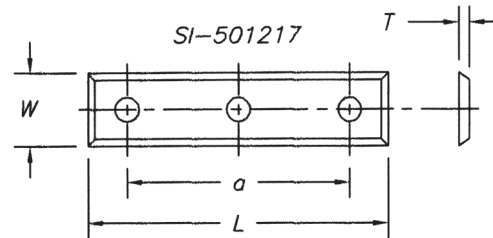
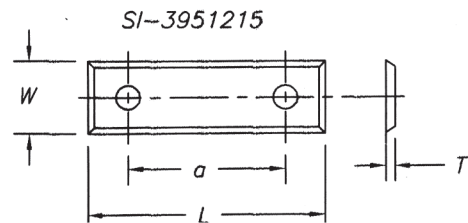

SI-201215AR

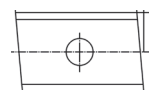

SI-301215AL

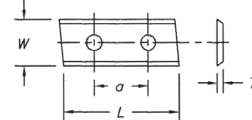

SI-301215DCL

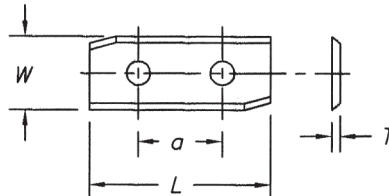

SI-305511BG

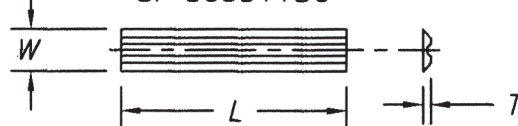

Solid Carbide Insert Knives

Part Number Description (L x W x T)

2 Sided Face Groove

SI-978152	9.7 x 8 x 1.5 Face Groove
SI-117815	11.7 x 8 x 1.5 Face Groove
SI-1478152	14.7 x 8 x 1.5 Face Groove
SI-125511FG	12 x 5.5 x 1.1 Face Groove
SI-197815	19.7 x 8 x 1.5 Face Groove
SI-205511FG	20 x 5.5 x 1.1 Face Groove
SI-305511FG	30 x 5.5 x 1.1 Face Groove
SI-405511FG	40 x 5.5 x 1.1 Face Groove
SI-505511FG	50 x 5.5 x 1.1 Face Groove
SI-508015FG	50 x 8 x 1.5 Face Groove
SI-608015FG	60 x 8 x 1.5 Face Groove

SI-205511FG

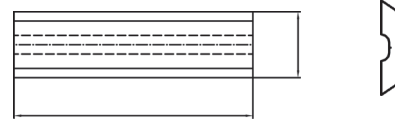

4 Sided Face Groove

SI-205511FG4	20 x 5.5 x 1.1 Face Groove
SI-255511FG4	25 x 5.5 x 1.1 Face Groove
SI-305511FG4	30 x 5.5 x 1.1 Face Groove
SI-355511FG4	35 x 5.5 x 1.1 Face Groove
SI-405511FG4	40 x 5.5 x 1.1 Face Groove
SI-505511FG4	50 x 5.5 x 1.1 Face Groove

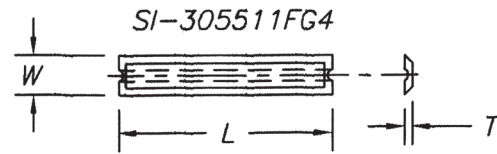

4 Sided Back & Cross Groove

SI-205511BCG	20 x 5.5 x 1.1
SI-305511BCG	30 x 5.5 x 1.1
SI-405511BCG	40 x 5.5 x 1.1
SI-505511BCG	50 x 5.5 x 1.1

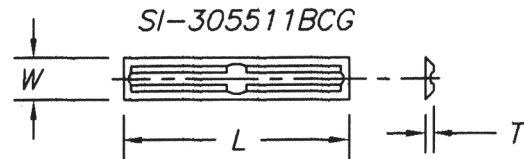

Chipbreaker Knives

SI-151520CB	15 x 15 x 2.0 4 Sided
SI-201215CB	20 x 12 x 1.5 2 Sided
SI-301215CB	30 x 12 x 1.5 2 Sided
SI-501215CB	50 x 12 x 1.5 2 Sided

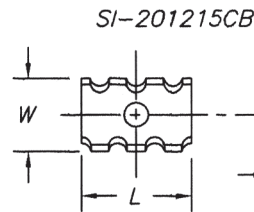

Radius Knives

SIR-121452L-2	12 x 14.5 x 2 LH 2mm Radius
SIR-121452R-2	12 x 14.5 x 2 RH 2mm Radius
NEW SIR-121452L-25	12 x 14.5 x 2 LH 2.5mm Radius
NEW SIR-121452R-25	12 x 14.5 x 2 RH 2.5mm Radius
SIR-121452L-3	12 x 14.5 x 2 LH 3mm Radius
SIR-121452R-3	12 x 14.5 x 2 RH 3mm Radius

SIR-121452R

SIR-121452L



Radius Knives

NEW SIR-151452L-2	15 x 14.5 x 2 LH 2mm Radius
NEW SIR-151452R-2	15 x 14.5 x 2 RH 2mm Radius
NEW SIR-151452L-25	15 x 14.5 x 2 LH 2.5mm Radius
NEW SIR-151452R-25	15 x 14.5 x 2 RH 2.5mm Radius
SIR-151452L-3	15 x 14.5 x 2 LH 3mm Radius
SIR-151452R-3	15 x 14.5 x 2 RH 3mm Radius
SIR-1961522L-2	19.6 x 15.2 x 2 LH 2mm Radius
SIR-1961522R-2	19.6 x 15.2 x 2 RH 2mm Radius
SIR-19615223L-3	19.6 x 15.2 x 2 LH 3mm Radius
SIR-19615223R-3	19.6 x 15.2 x 2 RH 3mm Radius

SIR-151452R

SIR-151452L



1

2

3

4

5

6

7

8

9

10

Solid Carbide Insert Knives

Part Number Description (L x W x T)

Double Radius Knives

SIDR-161752-2	16 x 17.5 x 2.0 R-2
SIDR-161752-3	16 x 17.5 x 2.0 R-3
SIDR-161752-4	16 x 17.5 x 2.0 R-4
SIDR-161752-5	16 x 17.5 x 2.0 R-5

SIDR-161752-4

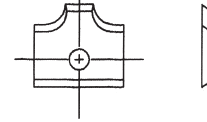

Radius Profile Knives

SIRP-12712732-2	12.7 x 12.7 x 3.2 R-2
SIRP-12712732-3	12.7 x 12.7 x 3.2 R-3

SIRP-12712732-2



Leitz Systems® Face Groove

SILS-778015	7.7 x 8.0 x 1.5
SILS-978015	9.7 x 8.0 x 1.5
SILS-1178015	11.7 x 8.0 x 1.5
SILS-1478018	14.7 x 8.0 x 1.5
SILS-1978015	19.7 x 8.0 x 1.5
SILS-2478015	24.7 x 8.0 x 1.5
SILS-308015	30 x 8.0 x 1.5
SILS-358015	35 x 8.0 x 1.5
SILS-408015	40 x 8.0 x 1.5
SILS-458015	45 x 8.0 x 1.5
SILS-508015	50 x 8.0 x 1.5
SILS-608015	60 x 8.0 x 1.5
SILS-708015	70 x 8.0 x 1.5
SILS-808015	80 x 8.0 x 1.5
SILS-1008015	100 x 8.0 x 1.5
SILS-1208015	120 x 8.0 x 1.5

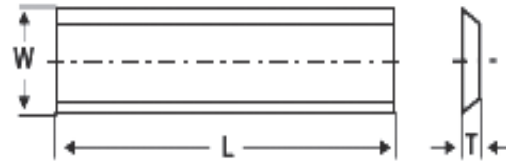

Portable Planers Back Groove

SIPP-565511	56 x 5.5 x 1.1	Adler
SIPP-605511	60 x 5.5 x 1.1	Wegoma
SIPP-755511	75.5 x 5.5 x 1.1	AEG, Bosch, Festo, Haffner, Kress, Mafell, Metabo, Scheer, Skill, Holz-Her
SIPP-757512	75.7 x 5.5 x 1.2	Black & Decker
SIPP-785511	78 x 5.5 x 1.1	Virutex
SIPP-8055912	80.5 x 5.9 x 1.2	ELU
SIPP-8055511	80.5 x 5.5 x 1.1	ELU
SIPP-825511	82 x 5.5 x 1.1	AEG, Black & Decker, Bosch, ALU, Fein, Felisatti, Haffner, Hitachi, Holz-Her, Mafell, Makita, Metabo, Peugot, Ryobi, Skil
SIPP-8275511	82.7 x 5.5 x 1.1	Black & Decker
SIPP-925511	92 x 5.5 x 1.1	AEG, Hitachi, Ryobi
SIPP-1025511	102 x 5.5 x 1.1	AEG



Standard Reversible Insert Knives

Part Number Description (L x W x T)

Scraper Knives 6 degree

SIS-2012202	20 x 12 x 2.0 R-2
SIS-2012203	20 x 12 x 2.0 R-3
SIS-2012204	20 x 12 x 2.0 R-4
SIS-2012205	20 x 12 x 2.0 R-5

SIS-2012202

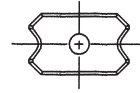

Triangle Spur Knives

SITS-221920	22 x 19 x 2.0
-------------	---------------

SITS-221920



Spur/Grooving Knives

SISG-141420-2	14 x 14 x 2.0 2mm Radius
SISG-1818195	18 x 18 x 1.95
SISG-1818245	18 x 18 x 2.45
SISG-1818295	18 x 18 x 2.95
SISG-1818370	18 x 18 x 3.70

SISG-1818195

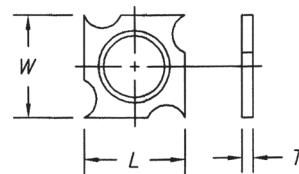

Spur/Grooving Knives

SISG-142820	14 x 28 x 2.0 30 Degree
SISG-161630	16 x 16 x 3.0 32 Degree

SISG-142820

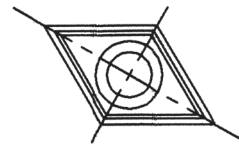

Spur/Grooving Knives

SISG-341640	34 x 16 x 4.0
SISG-341650	34 x 16 x 5.0
SISG-341660	34 x 16 x 6.0
SISG-341670	34 x 16 x 7.0

SISG-341640

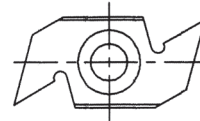

Spur Knives

SISP-185735	18 x 5.7 x 3.5
-------------	----------------

SISP-185735

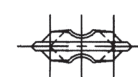

Radius Knives

SI-301402LH	30 x 14 x 2 LH	3mm Radius LH
SI-301402RH	30 x 14 x 2 RH	3mm Radius RH

SI-301402LH

SI-301402RH

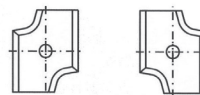

V Groove Knives

SI-3951215V	39.5 x 12 x 1.5 V
-------------	-------------------

SI-3951215V

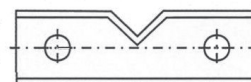

1

2

3

4

5

6

7

8

9

10

Standard Reversible Insert Knives

Leitz Systems "BG - TEST"

Part Number Description (L x W x T)



Leitz Systems "BG - TEST"

SI-152380-210 15 x 23 x 8 (21/0-45°)



SI-152380-210

SI-152390-220 15 x 23 9 (22/0 R3)

SI-152373-223 15 x 23 7.3 (22/3 R2)

SI-152370-224 15 x 23 7.0 (22/4 R1.5)

SI-152390-225 15 x 23 9.0 (22/5 R3F)



SI-152390-220



SI-152390-221

SI-152390-221 15 x 23 x 9.0 (22/1 R3)

SI-1525773-240 15 x 25.7 x 7.3 (24/0 R5)

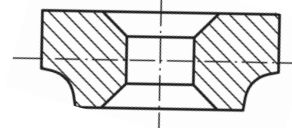

SI-1525773-241

SI-1525773-241 15 x 25.7 x 7.3 (24/1 R5)



Quadromat, IMA, MFA

SIR-121802-2LH 12 x 18 2 x 2mm Radius LH - Quadromat

SIR-121802-2RH 12 x 18 2 x 2mm Radius RH - Quadromat

SIR-121802-3LH 12 x 18 2 x 3mm Radius LH - Quadromat

SIR-121802-3RH 12 x 18 2 x 3mm Radius LH - Quadromat

SIR-121802-2LH-MFA 12 x 18 2 x 2mm Radius LH - Quadromat

SIR-121802-2RH-MFA 12 x 18 2 x 2mm Radius RH - Quadromat

SIR-121802-3LH-MFA 12 x 18 2 x 3mm Radius LH - Quadromat

SIR-121802-3RH-MFA 12 x 18 2 x 3mm Radius LH - Quadromat



SIR-121802-LH



SIR-121802-RH

Spiral Plus Molder Heads

AIRCRAFT GRADE ALUMINUM BODY

Part Number	Cutting Diameter	Cutting Length	Bore	Wings
SESPM-54-416	5"	4"	All	4
SESPM-56-420	5"	6"	All	4
SESPM-59-448	5"	9"	All	4
SESPM-54-624	5"	4"	All	6
SESPM-56-630	5"	6"	All	6
SESPM-59-660	5"	9"	All	6
SESPM-64-416	6"	4"	All	4
SESPM-66-420	6"	6"	All	4
SESPM-69-448	6"	9"	All	4
SESPM-64-624	6"	4"	All	6
SESPM-66-630	6"	6"	All	6
SESPM-69-660	6"	9"	All	6

1 13/16" is the most common bore.

SPIRAL PLUS PROFILE SHAPER HEADS

Part Number	Cutting Diameter	Cutting Length	Bore	Wings
SESP-44-416	4"	4"	1 1/4"	4
SESP-45-420	4"	5"	1 1/4"	4
SESP-46-424	4"	6"	1 1/4"	4
SESP-44-624	4"	4"	1 1/4"	6
SESP-45-630	4"	5"	1 1/4"	6
SESP-46-636	4"	6"	1 1/4"	6

RB41250 4" Diameter Rub Bearing

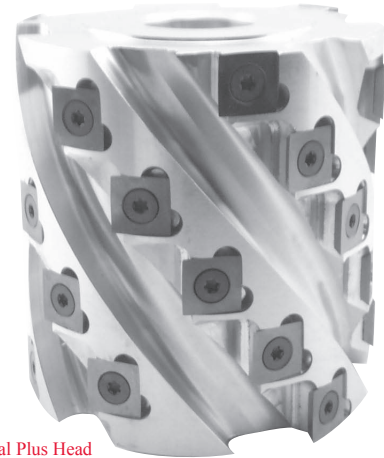

Spiral Plus Head

REPLACEMENT PARTS

Part Number	Description
SI-151525	Replacement Insert 15 x 15 x 2.5 (pack of 10)
SIS-Screw	Replacement Screw

COMPONENT PARTS FOR INSERT TOOLING

Part Number	Description	Pack	Sides
Inserts			
SI-301215	30 x 12 x 1.5	10	2 sided
SI-401215	40 x 12 x 1.5	10	2 sided
SI-501215	50 x 12 x 1.5	10	2 sided
For End Cutting			
SI-121215	12 x 12 x 1.5	10	4 sided
SI-2951215	29.5 x 12 x 1.5	10	4 sided
SI-3951215	39.5 x 12 x 1.5	10	4 sided
SI-4951215	49.5 x 12 x 1.5	10	4 sided
Wrenches			
SE-T8	T8 x 60 Torx Wrench	1	
SI-Wrench	T15 Flag Style	1	
SI-1580 Wrench	T15 Torx Wrench	1	
SI-25100Wrench	T25 x 100 Torx Wrench	1	
Screws			
SICS-Screw	Torx Screw		4
SI4-Screw	Torx Screw		4
SI35-Screw	Torx Screw		4
SEI-Screw	Torx Screw for SEIS1		EA
SIGSH-Screw	Torx Screw for Insert Heads		
SICS-Screw	Torx Screw for Insert Bits		EA
SI-Screw10-32x6	Screws fro SECS143IR		EA
SI-Screw10-32x9	Screws for Bolt in Inserts		EA

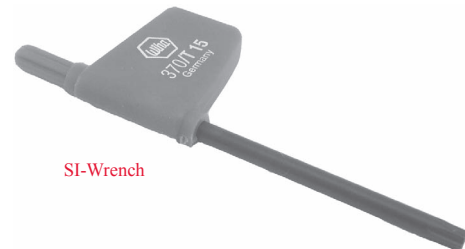

SI-Wrench



SI-1580 Wrench

1

2

3

4

5

6

7

8

9

10

High-Speed Steel (HSS 60-16) Molder Bars

CORRUGATED BACK • 25" LONG

BEVEL BOTTOM

5/16" Thick

HSS M2 Part Number	W x T x L Description
SEM2-1250-516	1-1/4" x 5/16" x 25"
SEM2-1500-516	1-1/2" x 5/16" x 25"
SEM2-1750-516	1-3/4" x 5/16" x 25"
SEM2-2000-516	2" x 5/16" x 25"
SEM2-2250-516	2-1/4" x 5/16" x 25"
SEM2-2500-516	2-1/2" x 5/16" x 25"
SEM2-2750-516	2-3/4" x 5/16" x 25"
SEM2-3000-516	3" x 5/16" x 25"

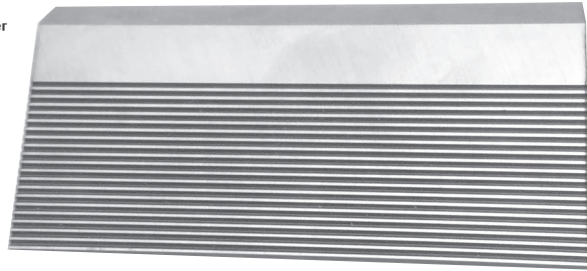

1/4" Thick

HSS M2 Part Number	W x T x L Description
SEM2-1250-14	1-1/4" x 1/4" x 25"
SEM2-1500-14	1-1/2" x 1/4" x 25"
SEM2-1750-14	1-3/4" x 1/4" x 25"
SEM2-2000-14	2" x 1/4" x 25"
SEM2-2250-14	2-1/4" x 1/4" x 25"
SEM2-2500-14	2-1/2" x 1/4" x 25"

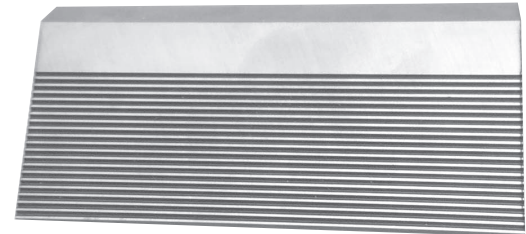
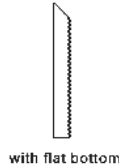

FLAT BOTTOM



5/16" Thick

HSS M2 Part Number	W x T x L Description
SEM2C-516-1250	1-1/4" x 5/16" x 25"
SEM2C-516-1500	1-1/2" x 5/16" x 25"
SEM2C-516-1750	1-3/4" x 5/16" x 25"
SEM2C-516-2000	2" x 5/16" x 25"
SEM2C-516-2250	2-1/4" x 5/16" x 25"
SEM2C-516-2500	2-1/2" x 5/16" x 25"
SEM2C-516-2750	2-3/4" x 5/16" x 25"
SEM2C-516-3000	3" x 5/16" x 25"

1/4" Thick

HSS M2 Part Number	W x T x L Description
SEM2C-14-1250	1-1/4" x 1/4" x 25"
SEM2C-14-1500	1-1/2" x 1/4" x 25"
SEM2C-14-1750	1-3/4" x 1/4" x 25"
SEM2C-14-2000	2" x 1/4" x 25"
SEM2C-14-2250	2-1/4" x 1/4" x 25"
SEM2C-14-2500	2-1/2" x 1/4" x 25"

WILLIAM & HUSSEY™



HSS M2 Part Number	W x T x L	Description
SEWH-316-2000	2" x 3/16" x 25"	Smooth
SEWH-316-2000C	2" x 3/16" x 25"	60° Corrugated
SEWH-14-2000	2" x 1/4" x 25"	Smooth
SEWH-14-2000C	2" x 1/4" x 25"	60° Corrugated
SEWH-14-2250	2-1/4" x 1/4" x 25"	Smooth
SEWH-14-2250C	2-1/4" x 1/4" x 25"	60° Corrugated
SEWH-14-2500	2-1/2" x 1/4" x 25"	Smooth
SEWH-14-2500C	2-1/2" x 1/4" x 25"	60° Corrugated

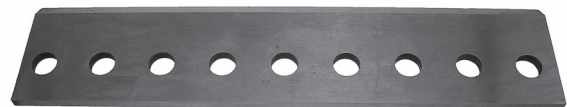

Corrugated Back Molder Heads



Molder Head

12° or 20° Hook

4" or 100mm DIAMETER x 1 1/4" BORE x 2 KNIFE (Specify Hook)

Part Number	Description
SEMH422ST	2" CL
SEMH424ST	4" CL
SEMH426ST	6" CL

4" or 100mm DIAMETER x 1 1/4" BORE x 4 KNIFE (Specify Hook)

Part Number	Description
SEMH442ST	2" CL
SEMH444ST	4" CL
SEMH446ST	6" CL

5" or 137mm DIAMETER x 1 1/2" or 44mm BORE x 4 KNIFE (Specify Hook)

Part Number	Description
SEMH542ST	2" CL
SEMH544ST	4" CL
SEMH546ST	6" CL
SEMH549ST	9" CL

150mm DIAMETER x 1 13/16" or 50mm BORE x 4 KNIFE (Specify Hook)

Part Number	Description
SEMH642ST	2" CL
SEMH644ST	4" CL
SEMH646ST	6" CL
SEMH649ST	9" CL

150mm DIAMETER x 1 13/16", 2 1/8" or 50mm Bore x 6 KNIFE (Specify Hook)

Part Number	Description
SEMH662ST	2" CL
SEMH664ST	4" CL
SEMH666ST	6" CL
SEMH669ST	9" CL

*Many sizes also available with Hydro Bore
Self-Centering Sleeves Quoted on Request*

STB Carbide Strips

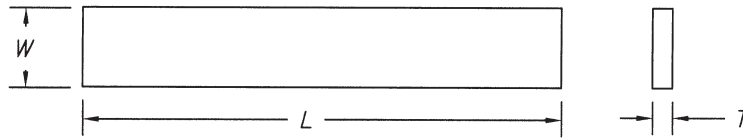

Tolerances
 Length +/- 0.080
 Width +/- 0.020
 Thickness +/- 0.004

Please Specify Grade Grade #
 C2M C2 Micrograin
 CRC Crack Resistant Carbide

STB Strips	Part Number	Thickness	Width	Length
	STB310	3/32" (0.093")	5/16" (0.312")	6"
	STB312	3/32" (0.093")	3/8" (0.375")	6"
	STB316	3/32" (0.093")	1/2" (0.500")	6"
	STB320	3/32" (0.093")	5/8" (0.625")	6"
	STB324	3/32" (0.093")	3/4" (0.750")	6"
	STB328	3/32" (0.093")	7/8" (0.875")	6"
	STB332	3/32" (0.093")	1" (1.000")	6"
	STB336	3/32" (0.093")	1-1/8" (1.125")	6"
	STB340	3/32" (0.093")	1-1/4" (1.250")	6"
	STB344	3/32" (0.093")	1-3/8" (1.375")	6"
	STB348	3/32" (0.093")	1-1/2" (1.500")	6"
	STB410	1/8" (0.125")	5/16" (0.312")	6"
	STB412	1/8" (0.125")	3/8" (0.375")	6"
	STB416	1/8" (0.125")	1/2" (0.500")	6"
	STB420	1/8" (0.125")	5/8" (0.625")	6"
	STB424	1/8" (0.125")	3/4" (0.750")	6"
	STB428	1/8" (0.125")	7/8" (0.875")	6"
	STB432	1/8" (0.125")	1" (1.000")	6"
	STB436	1/8" (0.125")	1-1/8" (1.125")	6"
	STB440	1/8" (0.125")	1-1/4" (1.250")	6"
	STB444	1/8" (0.125")	1-3/8" (1.375")	6"
	STB448	1/8" (0.125")	1-1/2" (1.500")	6"
	STB510	5/32" (0.156")	5/16" (0.312")	6"
	STB512	5/32" (0.156")	3/8" (0.375")	6"
	STB516	5/32" (0.156")	1/2" (0.500")	6"
	STB520	5/32" (0.156")	5/8" (0.625")	6"
	STB524	5/32" (0.156")	3/4" (0.750")	6"
	STB528	5/32" (0.156")	7/8" (0.875")	6"
	STB532	5/32" (0.156")	1" (1.000")	6"
	STB536	5/32" (0.156")	1-1/8" (1.125")	6"
	STB540	5/32" (0.156")	1-1/4" (1.250")	6"
	STB544	5/32" (0.156")	1-3/8" (1.375")	6"
	STB548	5/32" (0.156")	1-1/2" (1.500")	6"
	STB610	3/16" (0.187")	5/16" (0.312")	6"
	STB612	3/16" (0.187")	3/8" (0.375")	6"
	STB616	3/16" (0.187")	1/2" (0.500")	6"
	STB620	3/16" (0.187")	5/8" (0.625")	6"
	STB624	3/16" (0.187")	3/4" (0.750")	6"
	STB628	3/16" (0.187")	7/8" (0.875")	6"
	STB632	3/16" (0.187")	1" (1.000")	6"
	STB636	3/16" (0.187")	1-1/8" (1.125")	6"
	STB640	3/16" (0.187")	1-1/4" (1.250")	6"
	STB644	3/16" (0.187")	1-3/8" (1.375")	6"
	STB648	3/16" (0.187")	1-1/2" (1.500")	6"

1

2

3

4

5

6

7

8

9

10

Carbide Saw Tips

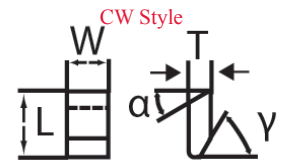

Tips are Pretinned Couple Day Delivery
Braze Tips also available

Sold in Packs of 50 Pieces

CWA

Style	Length	Width	Thickness	a	B	Y	TC6CR	T10MG	T06MF	T04F	T12M	T15M
7130	0.250	0.130	0.062	30	0	60	113812	113816	113820	N/A	N/A	N/A
7160	0.250	0.160	0.062	30	0	60	113813	113817	113821	N/A	N/A	N/A
7180	0.250	0.180	0.062	30	0	60	113814	113818	113822	N/A	N/A	N/A
7200	0.250	0.200	0.062	30	0	60	113815	113819	113823	N/A	N/A	N/A

CWB

7100	0.281	0.100	0.078	30	0	60	113824	113836	113848	N/A	N/A	N/A
7110	0.281	0.110	0.078	30	0	60	113825	113837	113849	N/A	N/A	N/A
7120	0.281	0.120	0.078	30	0	60	113826	113838	113850	N/A	N/A	N/A
7135	0.281	0.135	0.078	30	0	60	113827	113839	113851	N/A	N/A	N/A
7150	0.281	0.150	0.078	30	0	60	113828	113840	113852	N/A	N/A	N/A
7165	0.281	0.165	0.078	30	0	60	113829	113841	113853	N/A	N/A	N/A
7170	0.281	0.170	0.078	30	0	60	113830	113842	113854	N/A	N/A	N/A
7180	0.281	0.180	0.078	30	0	60	113831	113843	113855	N/A	N/A	N/A
7195	0.281	0.195	0.078	30	0	60	113832	113844	113856	N/A	N/A	N/A
7200	0.281	0.200	0.078	30	0	60	113833	113845	113857	N/A	N/A	N/A
7215	0.281	0.215	0.078	30	0	60	113834	113846	113858	N/A	N/A	N/A
7230	0.281	0.230	0.078	30	0	60	113835	113847	113859	N/A	N/A	N/A

CWC

7100	0.281	0.100	0.093	30	0	60	N/A	N/A	113868	113860	N/A	N/A
7125	0.281	0.125	0.093	30	0	60	N/A	N/A	113869	113861	N/A	N/A
7135	0.281	0.135	0.093	30	0	60	N/A	N/A	113870	113862	N/A	N/A
7150	0.281	0.135	0.093	30	0	60	N/A	N/A	113871	113863	N/A	N/A
7165	0.281	0.165	0.093	30	0	60	N/A	N/A	113872	113864	N/A	N/A
7195	0.281	0.195	0.093	30	0	60	N/A	N/A	113873	113865	N/A	N/A
7215	0.281	0.215	0.093	30	0	60	N/A	N/A	113874	113866	N/A	N/A
7250	0.281	0.250	0.093	30	0	60	N/A	N/A	113875	113867	N/A	N/A

CWD

7100	0.312	0.100	0.093	30	0	60	111288	112629	111311	N/A	N/A	111334
7110	0.312	0.110	0.093	30	0	60	111289	112630	111312	N/A	N/A	111335
7115	0.312	0.115	0.093	30	0	60	111290	112631	111313	N/A	N/A	111336
7120	0.312	0.120	0.093	30	0	60	111291	112632	111314	N/A	N/A	111337
7125	0.312	0.125	0.093	30	0	60	111292	112633	111315	N/A	N/A	111338
7130	0.312	0.130	0.093	30	0	60	111293	112634	111316	N/A	N/A	111339
7135	0.312	0.135	0.093	30	0	60	111294	112635	111317	N/A	N/A	111340
7140	0.312	0.140	0.093	30	0	60	111295	112636	111318	N/A	N/A	111341
7150	0.312	0.150	0.093	30	0	60	111296	112637	111319	N/A	N/A	111342
7160	0.312	0.160	0.093	30	0	60	111297	112638	111320	N/A	N/A	111343
7165	0.312	0.165	0.093	30	0	60	111298	112639	111321	N/A	N/A	111344
7170	0.312	0.170	0.093	30	0	60	111299	112640	111322	N/A	N/A	111345
7175	0.312	0.180	0.093	30	0	60	111300	112641	111323	N/A	N/A	111346
7180	0.312	0.180	0.093	30	0	60	111301	112642	111324	N/A	N/A	111347
7185	0.312	0.185	0.093	30	0	60	111302	112643	111325	N/A	N/A	111348
7190	0.312	0.190	0.093	30	0	60	111303	112644	111326	N/A	112656	111349
7200	0.312	0.200	0.093	30	0	60	111304	112645	111327	N/A	N/A	111350
7215	0.312	0.215	0.093	30	0	60	111305	112646	111328	N/A	N/A	111351
7220	0.312	0.220	0.093	30	0	60	111306	112647	111329	N/A	N/A	111352
7230	0.312	0.230	0.093	30	0	60	111307	112648	111330	N/A	N/A	111353
7240	0.312	0.240	0.093	30	0	60	111308	112649	111331	N/A	N/A	111354
7250	0.312	0.250	0.093	30	0	60	111309	112650	111332	N/A	N/A	111355
7280	0.312	0.280	0.093	30	0	60	112653	112651	112654	N/A	N/A	112655
7312	0.312	0.312	0.093	30	0	60	111310	112652	111333	N/A	N/A	111356

CWE

7110	0.375	0.110	0.093	30	0	60	112657	N/A	N/A	N/A	N/A	N/A
7130	0.375	0.130	0.093	30	0	60	111357	111368	111379	N/A	N/A	N/A
7140	0.375	0.140	0.093	30	0	60	111358	111369	111380	N/A	N/A	N/A
7150	0.375	0.150	0.093	30	0	60	111359	111370	111381	N/A	N/A	N/A
7165	0.375	0.165	0.093	30	0	60	111360	111371	111382	N/A	N/A	N/A
7185	0.375	0.185	0.093	30	0	60	111361	111372	111383	N/A	N/A	N/A



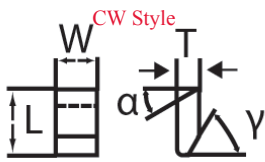

Carbide Saw Tips

Tips are Pretinned Couple Day Delivery
Brazed Tips also available

Sold in Packs of 50 Pieces

1

CWE

Style	Length	Width	Thickness	a	B	Y	TC6CR	T10MG	T06MF	T04F	T12M	T15M
7200	0.375	0.200	0.093	30	0	60	111362	111373	111384	N/A	N/A	N/A
7215	0.375	0.215	0.093	30	0	60	111363	111374	111385	N/A	N/A	N/A
7225	0.375	0.225	0.093	30	0	60	112658	112659	112660	N/A	N/A	N/A
7230	0.375	0.230	0.093	30	0	60	111364	111375	111386	N/A	N/A	N/A
7250	0.375	0.250	0.093	30	0	60	111365	111376	111387	N/A	N/A	N/A
7281	0.375	0.281	0.093	30	0	60	111366	111377	111388	N/A	N/A	N/A
7312	0.375	0.200	0.093	30	0	60	111367	111378	111389	N/A	N/A	N/A

2

CWF

7110	0.500	0.110	0.125	35	0	70	N/A	111225	107257	N/A	109391	N/A
7115	0.500	0.115	0.125	35	0	70	N/A	111226	107258	N/A	109392	N/A
7120	0.500	0.120	0.125	35	0	70	N/A	111227	107259	N/A	109393	N/A
7125	0.500	0.125	0.125	35	0	70	N/A	111228	107260	N/A	109394	N/A
7130	0.500	0.130	0.125	35	0	70	N/A	111229	107261	N/A	109395	N/A
7140	0.500	0.140	0.125	35	0	70	N/A	111230	107263	N/A	109397	N/A
7150	0.500	0.150	0.125	35	0	70	N/A	111231	107265	N/A	109399	N/A
7160	0.500	0.160	0.125	35	0	70	N/A	111232	107266	N/A	109400	N/A
7165	0.500	0.165	0.125	35	0	70	N/A	111233	107267	N/A	109401	N/A
7170	0.500	0.170	0.125	35	0	70	N/A	111234	107268	N/A	109402	N/A
7180	0.500	0.180	0.125	35	0	70	N/A	111235	107269	N/A	109403	N/A
7185	0.500	0.185	0.125	35	0	70	N/A	112661	112663	N/A	112664	N/A
7190	0.500	0.190	0.125	35	0	70	N/A	111236	107271	N/A	109405	N/A
7200	0.500	0.200	0.125	35	0	70	N/A	111237	107272	N/A	109406	N/A
7210	0.500	0.210	0.125	35	0	70	N/A	111238	107273	N/A	109407	N/A
7215	0.500	0.215	0.125	35	0	70	N/A	111239	107274	N/A	109408	N/A
7220	0.500	0.220	0.125	35	0	70	N/A	111240	107275	N/A	109409	N/A
7230	0.500	0.230	0.125	35	0	70	N/A	111241	107276	N/A	109410	N/A
7240	0.500	0.240	0.125	35	0	70	N/A	111242	107278	N/A	109412	N/A
7250	0.500	0.250	0.125	35	0	70	112665	111243	107279	N/A	109413	N/A
7260	0.500	0.260	0.125	35	0	70	N/A	111244	107280	N/A	109414	N/A
7270	0.500	0.270	0.125	35	0	70	N/A	111245	107282	N/A	109416	N/A
7275	0.500	0.275	0.125	35	0	70	N/A	111246	107283	N/A	109417	N/A
7280	0.500	0.280	0.125	35	0	70	N/A	111247	107284	N/A	109418	N/A
7290	0.500	0.290	0.125	35	0	70	N/A	111248	107285	N/A	109419	N/A
7300	0.500	0.300	0.125	35	0	70	N/A	111249	107286	N/A	109420	N/A
7310	0.500	0.310	0.125	35	0	70	N/A	111250	107287	N/A	109421	N/A
7312	0.500	0.312	0.125	35	0	70	N/A	111251	107288	N/A	109422	N/A
7330	0.500	0.330	0.125	35	0	70	N/A	111252	107290	N/A	109424	N/A
7375	0.500	0.375	0.125	35	0	70	N/A	111253	107294	N/A	109428	N/A
7400	0.500	0.400	0.125	35	0	70	N/A	N/A	N/A	N/A	112666	N/A
7437	0.500	0.437	0.125	35	0	70	N/A	111254	107297	N/A	109431	N/A
7500	0.500	0.500	0.125	35	0	70	N/A	111255	107298	N/A	109432	N/A
7625	0.500	0.625	0.125	35	0	70	N/A	111256	107300	N/A	109434	N/A
7687	0.500	0.687	0.125	35	0	70	N/A	111257	107301	N/A	109435	N/A
7750	0.500	0.750	0.125	35	0	70	N/A	111258	107302	N/A	109436	N/A

5

6

7

8

CWG

7110	0.375	0.110	0.125	30	0	60	107349	111259	107383	N/A	109437	107417
7120	0.375	0.110	0.125	30	0	60	107350	111260	107384	N/A	109438	107418
7125	0.375	0.110	0.125	30	0	60	N/A	N/A	112667	N/A	N/A	N/A
7130	0.375	0.110	0.125	30	0	60	107352	111261	107386	N/A	109440	107420
7140	0.375	0.110	0.125	30	0	60	107354	111262	107388	N/A	109442	107422
7150	0.375	0.110	0.125	30	0	60	107355	111263	107389	N/A	109443	107423
7160	0.375	0.110	0.125	30	0	60	107356	111264	107390	N/A	109444	107424
7165	0.375	0.110	0.125	30	0	60	107357	111265	107391	N/A	109445	107425
7170	0.375	0.110	0.125	30	0	60	107358	111266	107392	N/A	109446	107426
7175	0.375	0.110	0.125	30	0	60	107368	111267	107385	N/A	109450	107430
7180	0.375	0.110	0.125	30	0	60	107359	111268	107393	N/A	109447	107427
7185	0.375	0.110	0.125	30	0	60	107360	111269	107394	N/A	109448	107428
7190	0.375	0.110	0.125	30	0	60	107361	111270	107395	N/A	109449	107429
7200	0.375	0.110	0.125	30	0	60	107363	111271	107397	N/A	109451	107431

10

Tips are Pretinned Couple Day Delivery
Brazed Tips also available

Carbide Saw Tips

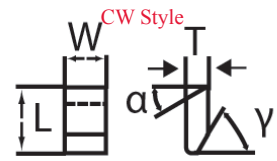

Sold in Packs of 50 Pieces

CWG

Style	Length	Width	Thickness	a	B	Y	TC6CR	T10MG	T06MF	T04F	T12M	T15M
7210	0.375	0.210	0.125	30	0	60	107364	111272	107398	N/A	109452	107432
7215	0.375	0.215	0.125	30	0	60	107365	111273	107399	N/A	109453	107433
7220	0.375	0.220	0.125	30	0	60	107366	111274	107400	N/A	109454	107434
7230	0.375	0.230	0.125	30	0	60	107368	111275	107402	N/A	109456	107436
7240	0.375	0.240	0.125	30	0	60	107369	111276	107403	N/A	109457	107437
7250	0.375	0.250	0.125	30	0	60	107370	111277	107404	N/A	109458	107438
7260	0.375	0.260	0.125	30	0	60	107371	111278	107405	N/A	109459	107439
7270	0.375	0.270	0.125	30	0	60	107373	111279	107407	N/A	109461	107441
7275	0.375	0.275	0.125	30	0	60	107374	111280	107408	N/A	109462	107442
7280	0.375	0.280	0.125	30	0	60	107375	111281	107409	N/A	109463	107443
7300	0.375	0.300	0.125	30	0	60	107376	111282	107410	N/A	109464	107444
7310	0.375	0.310	0.125	30	0	60	107378	111283	107412	N/A	109466	107446
7312	0.375	0.375	0.125	30	0	60	107377	111284	107411	N/A	109465	107445
7350	0.375	0.350	0.125	30	0	60	107380	111285	107414	N/A	109468	111218
7400	0.375	0.400	0.125	30	0	60	107379	111286	107413	N/A	109467	107447
7500	0.375	0.500	0.125	30	0	60	107381	111287	107415	N/A	109469	107449

CWH

7120	0.344	0.120	0.125	30	0	60	114408	N/A	114410	114409	N/A	N/A
7135	0.344	0.135	0.125	30	0	60	114413	N/A	114411	114412	N/A	N/A
7140	0.344	0.140	0.125	30	0	60	114414	N/A	114416	114415	N/A	N/A
7150	0.344	0.150	0.125	30	0	60	114419	N/A	114417	114418	N/A	N/A
7160	0.344	0.160	0.125	30	0	60	114420	N/A	114422	114421	N/A	N/A
7165	0.344	0.165	0.125	30	0	60	114425	N/A	114423	114424	N/A	N/A
7180	0.344	0.180	0.125	30	0	60	114426	N/A	114428	114427	N/A	N/A
7185	0.344	0.185	0.125	30	0	60	114431	N/A	114429	114430	N/A	N/A
7190	0.344	0.190	0.125	30	0	60	114432	N/A	114434	114433	N/A	N/A
7200	0.344	0.200	0.125	30	0	60	114438	N/A	114435	114436	N/A	N/A
7210	0.344	0.210	0.125	30	0	60	114440	N/A	114442	114441	N/A	N/A
7215	0.344	0.215	0.125	30	0	60	114446	N/A	114443	114445	N/A	N/A
7220	0.344	0.220	0.125	30	0	60	114447	N/A	114449	114448	N/A	N/A
7230	0.344	0.230	0.125	30	0	60	114453	N/A	114451	114452	N/A	N/A
7240	0.344	0.240	0.125	30	0	60	114454	N/A	114456	114455	N/A	N/A
7250	0.344	0.250	0.125	30	0	60	114459	N/A	114457	114458	N/A	N/A
7260	0.344	0.260	0.125	30	0	60	114460	N/A	114462	114461	N/A	N/A

CWQ

7200	0.375	0.200	0.156	30	0	60	N/A	114464	114463	N/A	N/A	N/A
7230	0.375	0.230	0.156	30	0	60	N/A	114465	114466	N/A	N/A	N/A
7250	0.375	0.250	0.156	30	0	60	N/A	114468	114467	N/A	N/A	N/A
7300	0.375	0.300	0.156	30	0	60	N/A	114469	114470	N/A	N/A	N/A
7400	0.375	0.400	0.156	30	0	60	N/A	114472	114471	N/A	N/A	N/A
7530	0.375	0.430	0.156	30	0	60	N/A	114473	114474	N/A	N/A	N/A
7625	0.375	0.625	0.156	30	0	60	N/A	114476	114475	N/A	N/A	N/A

CWD Right

7165	0.312	0.165	0.093	30	0	60	111691	111701	111711	N/A	N/A	N/A
7185	0.312	0.185	0.093	30	0	60	111693	111703	111713	N/A	N/A	N/A
7200	0.312	0.200	0.093	30	0	60	111695	111705	111715	N/A	N/A	N/A
7215	0.312	0.215	0.093	30	0	60	111697	111707	111717	N/A	N/A	N/A
7250	0.312	0.250	0.093	30	0	60	111699	111709	111719	N/A	N/A	N/A



CWD Left

7165	0.312	0.165	0.093	30	0	60	111692	111702	111712	N/A	N/A	N/A
7185	0.312	0.185	0.093	30	0	60	111694	111704	111714	N/A	N/A	N/A
7200	0.312	0.200	0.093	30	0	60	111696	111706	111716	N/A	N/A	N/A
7215	0.312	0.215	0.093	30	0	60	111698	111708	111718	N/A	N/A	N/A
7250	0.312	0.250	0.093	30	0	60	111700	111710	111720	N/A	N/A	N/A



CWG Right

7230	0.375	0.230	0.125	30	0	60	N/A	N/A	112668	N/A	N/A	107451
7250	0.375	0.250	0.125	30	0	60	N/A	N/A	112669	N/A	N/A	107453
7265	0.375	0.265	0.125	30	0	60	N/A	N/A	112670	N/A	N/A	107465
7270	0.375	0.270	0.125	30	0	60	N/A	N/A	112671	N/A	N/A	107455



1

2

3

4

5

6

7

8

9

10

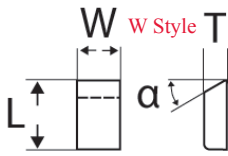

Carbide Saw Tips

Tips are Pretinned Couple Day Delivery
Brazed Tips also available



Sold in Packs of 50 Pieces

	Style	Length	Width	Thickness	a	B	Y	TC6CR	T10MG	T06MF	T04F	T12M	T15M	
1	CWG Left	7230	0.375	0.230	0.125	30	0	60	N/A	N/A	112672	N/A	N/A	107452
		7250	0.375	0.250	0.125	30	0	60	N/A	N/A	112673	N/A	N/A	107454
		7265	0.375	0.265	0.125	30	0	60	N/A	N/A	112674	N/A	N/A	107466
		7270	0.375	0.270	0.125	30	0	60	N/A	N/A	112675	N/A	N/A	107456
2	WA	7080	0.250	0.080	0.062	30	0	0	N/A	N/A	114137	114136	N/A	N/A
		7090	0.250	0.090	0.062	30	0	0	N/A	N/A	114138	114139	N/A	N/A
		7100	0.250	0.100	0.062	30	0	0	N/A	N/A	114141	114140	N/A	N/A
		7110	0.250	0.110	0.062	30	0	0	N/A	N/A	114142	114143	N/A	N/A
		7115	0.250	0.115	0.062	30	0	0	N/A	N/A	114145	114144	N/A	N/A
		7120	0.250	0.120	0.062	30	0	0	N/A	N/A	114146	114147	N/A	N/A
		7130	0.250	0.130	0.062	30	0	0	N/A	N/A	114149	114148	N/A	N/A
		7145	0.250	0.145	0.062	30	0	0	N/A	N/A	114150	114151	N/A	N/A
		7160	0.250	0.160	0.062	30	0	0	N/A	N/A	114153	114152	N/A	N/A
		7180	0.250	0.180	0.062	30	0	0	N/A	N/A	114154	114155	N/A	N/A
		7200	0.250	0.200	0.062	30	0	0	N/A	N/A	114157	114156	N/A	N/A
3	WB	7215	0.250	0.215	0.062	30	0	0	N/A	N/A	114158	114160	N/A	N/A
		7100	0.281	0.100	0.078	30	0	0	N/A	114162	114161	N/A	N/A	N/A
		7105	0.281	0.105	0.078	30	0	0	N/A	114163	114164	N/A	N/A	N/A
		7120	0.281	0.120	0.078	30	0	0	N/A	114166	114165	N/A	N/A	N/A
		7135	0.281	0.135	0.078	30	0	0	N/A	114167	114168	N/A	N/A	N/A
		7150	0.281	0.150	0.078	30	0	0	N/A	114170	114169	N/A	N/A	N/A
		7165	0.281	0.165	0.078	30	0	0	N/A	114171	114172	N/A	N/A	N/A
		7180	0.281	0.180	0.078	30	0	0	N/A	114174	114173	N/A	N/A	N/A
		7185	0.281	0.185	0.078	30	0	0	N/A	114175	114176	N/A	N/A	N/A
		7195	0.281	0.195	0.078	30	0	0	N/A	114178	114177	N/A	N/A	N/A
		7200	0.281	0.200	0.078	30	0	0	N/A	114179	114180	N/A	N/A	N/A
4	WC	7215	0.281	0.215	0.078	30	0	0	N/A	114182	114181	N/A	N/A	N/A
		7250	0.281	0.250	0.078	30	0	0	N/A	114183	114184	N/A	N/A	N/A
		7100	0.281	0.100	0.093	30	0	0	N/A	N/A	114186	114185	N/A	N/A
		7125	0.281	0.125	0.093	30	0	0	N/A	N/A	114187	114188	N/A	N/A
		7135	0.281	0.135	0.093	30	0	0	N/A	N/A	114190	114189	N/A	N/A
		7150	0.281	0.150	0.093	30	0	0	N/A	N/A	114191	114192	N/A	N/A
		7165	0.281	0.165	0.093	30	0	0	N/A	N/A	114194	114193	N/A	N/A
		7100	0.312	0.100	0.93	30	0	0	114195	114198	114197	114196	N/A	N/A
		7110	0.312	0.110	0.93	30	0	0	114202	114199	114200	114201	N/A	N/A
		7115	0.312	0.115	0.93	30	0	0	114203	114206	114205	114204	N/A	N/A
		7120	0.312	0.120	0.93	30	0	0	114210	114207	114208	114209	N/A	N/A
7135	0.312	0.135	0.93	30	0	0	114211	114214	114213	114212	N/A	N/A		
7140	0.312	0.140	0.93	30	0	0	114218	114215	114216	114217	N/A	N/A		
7150	0.312	0.150	0.93	30	0	0	114219	114222	114221	114220	N/A	N/A		
7160	0.312	0.160	0.93	30	0	0	114226	114223	114224	114225	N/A	N/A		
7165	0.312	0.165	0.93	30	0	0	114227	114230	114229	114228	N/A	N/A		
7170	0.312	0.170	0.93	30	0	0	114234	114231	114232	114233	N/A	N/A		
7185	0.312	0.185	0.93	30	0	0	114235	114239	114238	114237	N/A	N/A		
7190	0.312	0.190	0.93	30	0	0	114243	114240	114241	114242	N/A	N/A		
7200	0.312	0.200	0.93	30	0	0	114244	114247	114246	114245	N/A	N/A		
7215	0.312	0.215	0.93	30	0	0	114251	114248	114249	114250	N/A	N/A		
7230	0.312	0.230	0.93	30	0	0	114252	114255	114254	114253	N/A	N/A		
7240	0.312	0.240	0.93	30	0	0	114259	114256	114257	114258	N/A	N/A		
7250	0.312	0.250	0.93	30	0	0	114260	114263	114262	114261	N/A	N/A		
7280	0.312	0.280	0.93	30	0	0	114267	114264	114265	114266	N/A	N/A		
7312	0.312	0.312	0.93	30	0	0	114268	114271	114270	114269	N/A	N/A		

Tips are Pretinned Couple Day Delivery
Brazed Tips also available

Carbide Saw Tips

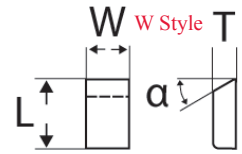

Sold in Packs of 50 Pieces

	Style	Length	Width	Thickness	a	B	Y	TC6CR	T10MG	T06MF	T04F	T12M	T15M
WE	7110	0.375	0.110	0.093	30	0	0	114274	114272	114273	N/A	N/A	N/A
	7130	0.375	0.130	0.093	30	0	0	114275	114277	114276	N/A	N/A	N/A
	7135	0.375	0.135	0.093	30	0	0	114280	114278	114279	N/A	N/A	N/A
	7140	0.375	0.140	0.093	30	0	0	114281	114283	114282	N/A	N/A	N/A
	7150	0.375	0.150	0.093	30	0	0	114286	114284	114285	N/A	N/A	N/A
	7165	0.375	0.165	0.093	30	0	0	114288	114290	114289	N/A	N/A	N/A
	7170	0.375	0.170	0.093	30	0	0	114293	114291	114292	N/A	N/A	N/A
	7185	0.375	0.185	0.093	30	0	0	114294	114296	114295	N/A	N/A	N/A
	7200	0.375	0.200	0.093	30	0	0	114299	114297	114298	N/A	N/A	N/A
	7215	0.375	0.215	0.093	30	0	0	114300	114302	114301	N/A	N/A	N/A
	7225	0.375	0.225	0.093	30	0	0	114305	114303	114304	N/A	N/A	N/A
	7235	0.375	0.235	0.093	30	0	0	114306	114308	114307	N/A	N/A	N/A
	7250	0.375	0.250	0.093	30	0	0	114311	114309	114310	N/A	N/A	N/A
	7265	0.375	0.265	0.093	30	0	0	114312	114314	114313	N/A	N/A	N/A
	7281	0.375	0.281	0.093	30	0	0	114317	114315	114316	N/A	N/A	N/A
	7312	0.375	0.312	0.093	30	0	0	114318	114320	114319	N/A	N/A	N/A
	7350	0.375	0.350	0.093	30	0	0	114323	114321	114322	N/A	N/A	N/A
7375	0.375	0.375	0.093	30	0	0	114324	114326	114325	N/A	N/A	N/A	
WF	7150	0.500	0.150	0.125	35	0	0	N/A	114327	114328	N/A	N/A	N/A
	7160	0.500	0.160	0.125	35	0	0	N/A	114330	114329	N/A	N/A	N/A
	7165	0.500	0.165	0.125	35	0	0	N/A	114334	114332	N/A	N/A	N/A
	7170	0.500	0.170	0.125	35	0	0	N/A	114335	114336	N/A	N/A	N/A
	7180	0.500	0.180	0.125	35	0	0	N/A	114338	114337	N/A	N/A	N/A
	7185	0.500	0.185	0.125	35	0	0	N/A	114339	114340	N/A	N/A	N/A
	7190	0.500	0.190	0.125	35	0	0	N/A	114342	114341	N/A	N/A	N/A
	7200	0.500	0.200	0.125	35	0	0	N/A	114343	114344	N/A	N/A	N/A
	7210	0.500	0.210	0.125	35	0	0	N/A	114346	114345	N/A	N/A	N/A
	7215	0.500	0.215	0.125	35	0	0	N/A	114347	114348	N/A	N/A	N/A
	7220	0.500	0.220	0.125	35	0	0	N/A	114350	114349	N/A	N/A	N/A
	7230	0.500	0.230	0.125	35	0	0	N/A	114351	114352	N/A	N/A	N/A
	7240	0.500	0.240	0.125	35	0	0	N/A	114354	114353	N/A	N/A	N/A
	7250	0.500	0.250	0.125	35	0	0	N/A	114355	114356	N/A	N/A	N/A
	7260	0.500	0.260	0.125	35	0	0	N/A	114358	114357	N/A	N/A	N/A
	7270	0.500	0.270	0.125	35	0	0	N/A	114359	114360	N/A	N/A	N/A
	7275	0.500	0.275	0.125	35	0	0	N/A	114362	114361	N/A	N/A	N/A
	7280	0.500	0.280	0.125	35	0	0	N/A	114363	114364	N/A	N/A	N/A
	7300	0.500	0.300	0.125	35	0	0	N/A	114366	114365	N/A	N/A	N/A
	7312	0.500	0.312	0.125	35	0	0	N/A	114367	114368	N/A	N/A	N/A
7350	0.500	0.350	0.125	35	0	0	N/A	114370	114369	N/A	N/A	N/A	
7375	0.500	0.375	0.125	35	0	0	N/A	114371	114372	N/A	N/A	N/A	
7400	0.500	0.400	0.125	35	0	0	N/A	114374	114373	N/A	N/A	N/A	
7437	0.500	0.437	0.125	35	0	0	N/A	114375	114376	N/A	N/A	N/A	
7500	0.500	0.500	0.125	35	0	0	N/A	114378	114377	N/A	N/A	N/A	
7625	0.500	0.625	0.125	35	0	0	N/A	114379	114380	N/A	N/A	N/A	
WG	7150	0.375	0.150	0.125	30	0	0	N/A	N/A	114381	N/A	N/A	N/A
	7165	0.375	0.165	0.125	30	0	0	N/A	N/A	114382	N/A	N/A	N/A
	7180	0.375	0.180	0.125	30	0	0	N/A	N/A	114383	N/A	N/A	N/A
	7185	0.375	0.185	0.125	30	0	0	N/A	N/A	114384	N/A	N/A	N/A
	7190	0.375	0.190	0.125	30	0	0	N/A	N/A	114385	N/A	N/A	N/A
	7200	0.375	0.200	0.125	30	0	0	N/A	N/A	114386	N/A	N/A	N/A
	7215	0.375	0.215	0.125	30	0	0	N/A	N/A	114387	N/A	N/A	N/A
	7220	0.375	0.220	0.125	30	0	0	N/A	N/A	114388	N/A	N/A	N/A
	7230	0.375	0.230	0.125	30	0	0	N/A	N/A	114389	N/A	N/A	N/A
	7240	0.375	0.240	0.125	30	0	0	N/A	N/A	114390	N/A	N/A	N/A
	7250	0.375	0.250	0.125	30	0	0	N/A	N/A	114391	N/A	N/A	N/A
	7265	0.375	0.265	0.125	30	0	0	N/A	N/A	114392	N/A	N/A	N/A
	7275	0.375	0.275	0.125	30	0	0	N/A	N/A	114393	N/A	N/A	N/A



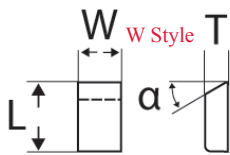

Carbide Saw Tips

Tips are Pretinned Couple Day Delivery
Brazed Tips also available

Sold in Packs of 50 Pieces

1

WG

Style	Length	Width	Thickness	a	B	Y	TC6CR	T10MG	T06MF	T04F	T12M	T15M
7280	0.375	0.280	0.125	30	0	0	N/A	N/A	114394	N/A	N/A	N/A
7300	0.375	0.300	0.125	30	0	0	N/A	N/A	114395	N/A	N/A	N/A
7312	0.375	0.312	0.125	30	0	0	N/A	N/A	114396	N/A	N/A	N/A
7350	0.375	0.350	0.125	30	0	0	N/A	N/A	114397	N/A	N/A	N/A
7400	0.375	0.400	0.125	30	0	0	N/A	N/A	114398	N/A	N/A	N/A
7500	0.375	0.500	0.125	30	0	0	N/A	N/A	114399	N/A	N/A	N/A

2

WQ

7200	0.375	0.200	0.156	30	0	0	N/A	114400	N/A	N/A	N/A	N/A
7265	0.375	0.265	0.156	30	0	0	N/A	114401	N/A	N/A	N/A	N/A
7300	0.375	0.300	0.156	30	0	0	N/A	114402	N/A	N/A	N/A	N/A
7335	0.375	0.335	0.156	30	0	0	N/A	114403	N/A	N/A	N/A	N/A
7400	0.375	0.400	0.156	30	0	0	N/A	114404	N/A	N/A	N/A	N/A
7460	0.375	0.460	0.156	30	0	0	N/A	114405	N/A	N/A	N/A	N/A
7500	0.375	0.500	0.156	30	0	0	N/A	114406	N/A	N/A	N/A	N/A

3

4

5

6

7

8

9

10

Planer Knives

1/8" Thickness

PLANER & JOINTER KNIFE SETS

Length	Width	T-1 HSS Part #	Carbide Tipped Part #	Knives in Set	Fits Planer / Jointer
4"	5/8"	PK7000	PKC7001	3	Delta 4", Atlas, Boice Crane, Old Craftsman & Similar Jointers
6"	5/8"	PK7002	PKC7003	3	Old Delta 6", TTL, Boice Crane, Craftsman, Rockwell
6"	5/8"	PK7004	N/A	4	Boice Crane
6"	3/4"	PK7006	PKC7007	3	Powermatic 50
6"	1"	PK7008	PKC7009	3	Grizzly
6-1/16"	5/8"	PK7010	N/A	3	Powermatic, Jet JJ-6
6-1/16"	13/16"	PK7012	PKC7013	3	Delta DJ-15, 37-154 & Similar 6" Jointers
6-1/8"	5/8"	PK7016	N/A	3	Craftsman
6-1/8"	11/16"	PK7018	PKC7019	3	Jet
8"	5/8"	PK7020	PKC7021	3	Old Delta 8", TTL, Boice Crane, Rockwell, Most 8" Imports
8"	3/4"	PK7022	PKC7023	3	Jet JJ-8, Powermatic 60, Pryor
8"	3/4"	PK7024	PKC7025	4	Bridgewood
8"	7/8"	PK7026	PKC7027	3	Powermatic 50
8"	1"	PK7028	PKC7029	3	Grizzly
8-1/16"	5/8"	PK7032	N/A	3	Delta
8-1/16"	3/4"	PK7034	N/A	3	Sunhill Machinery
8-1/16"	13/16"	PK7036	PKC7037	3	Delta DJ-20 Jointer & Similar
12"	3/4"	PK7038	N/A	3	Grizzly
12"	7/8"	PK7040	PKC7041	3	Powermatic & Parks
12"	1"	PK7042	PKC7043	3	Craftsman
12"	1-1/4"	PK7044	PKC7045	3	Northfield
12-1/4"	3/4"	PK7046	N/A	3	Boice Crane, Reliant, Wilke
12-1/4"	7/8"	PK7048	PKC7049	3	Powermatic
12-1/4"	1"	PK7050	PKC7051	3	Most European Combo Machines
12-1/2"	5/8"	PK7052	N/A	3	Boice Crane
12-1/2"	11/16"	PK7054	PKC7055	3	RBI Model 812, Foley-Belsaw, Jet
12-1/2"	3/4"	PK7056	PKC7057	3	Jet, Grizzly, Wilke, Reliant, Most 12" Imports
13-1/16"	5/8"	PK7058	PKC7059	3	Jet
13-1/8"	1"	PK7060	PKC7061	3	Delta RC-33 & DC-33 13" Planer, Rockwell
15"	1"	PK7062	PKC7063	3	Delta DC-380, Grizzly, Reliant, Woodtch, TLL, Jet
15-1/16"	1"	PK7064	N/A	3	Delta 22-677
15-3/4"	1-3/16"	PK7066	PKC7067	4	SCMI
16"	1"	PK7068	N/A	3	Jet JWP16
16"	1-1/8"	PK7070	N/A	4	Bridgewood, Crescent, Grizzly
16"	1-1/4"	PK7072	PKC7073	3	NorthField
16-3/16"	1-3/16"	PK7076	PKC7076	4	SCMI
16-1/2"	11/16"	PK7078	PKC7079	4	RBI Model 816
18-1/2"	11/16"	PK7086	PKC7087	3	Woodmaster
20"	1"	PK7088	PKC7089	3	Grizzly, Northwood
20"	1"	PK7090	PKC7091	4	Parks, TLL 20", Jet 208, Northstate
20"	1-1/8"	PK7092	PKC7093	4	Delta 20 x 9
20"	1-3/16"	PK7094	PKC7095	4	Delta 20" Planer, Many Imports
20"	1-1/4"	PK7096	N/A	3	Woodtek
20-3/16"	1-3/16"	PK7098	PKC7099	4	Delta DC-580
20-3/16"	1-3/8"	PK7100	PKC7101	4	Delta RC-51
20-1/2"	1-3/16"	PK7104	PKC7105	4	SCMI
22-1/8"	1"	PK7106	PKC7107	4	Powermatic 201
24-1/8"	1-3/16"	PK7110	PKC7111	4	Grizzly
24-1/4"	1-1/8"	PK7112	PKC7113	3	Delta 22-470
24-1/4"	1-1/8"	PK7114	PKC7115	4	Crescent (Delta)
24-3/4"	1-1/8"	PK7116	PKC7117	3	Jet 24H
24-13/16"	1-1/8"	PK7118	PKC7119	4	Delta RC-63
25"	11/16"	PK7120	PKC7121	3	Woodmaster 725
25"	1-1/4"	PK7122	PKC7123	4	
25"	1-3/8"	PK7124	N/A	4	
25-3/16"	1-3/8"	PK7126	PKC7127	4	SCMI F630 & F535



Planer Knives

PLANER & JOINTER KNIFE SETS

3/32" Thickness		T-1 HSS	Carbide Tipped	Knives	
Length	Width	Part #	Part #	in Set	Fits Planer / Jointer
6-1/8"	5/8"	PK7014	N/A	3	Delta 37-190, Jointer
8-1/16"	5/8"	PK7030	N/A	3	Delta
5/32" Thickness					
16-1/4"	1-1/4"	PK7074	PKC7075	3	Powermatic
18"	1-1/4"	PK7080	PKC7081	3	Powermatic
18-1/8"	1-1/8"	PK7082	PKC7083	3	Rockwell, Delta
18-1/4"	1-1/4"	PK7084	PKC7085	3	Powermatic
20-1/4"	1-1/4"	PK7102	PKC7103	3	Powermatic
24"	1-1/4"	PK7108	PKC7109	4	Powermatic, Northfield

Metric sizes available upon request

1

2

3

4

5

6

7

8

9

10

Replacement Knives For Terminus™ Heads

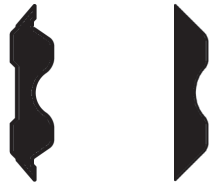

T-1 AVAILABLE UPON REQUEST, CALL FOR AVAILABILITY

Tersa™

Terminus™

TERMINUS™ PLANER HEAD KNIVES HIGH SPEED STEEL

	HSS Part #	L mm	W mm	T mm
	SE100348	50.0	14.0	2.55
	SE100350	60.0	14.0	2.55
	SE100349	80.0	14.0	2.55
	SE100297	100.0	14.0	2.55
	SE100351	110.0	14.0	2.55
	SE100352	120.0	14.0	2.55
	SE055461	130.0	14.0	2.55
NEW	SE114608	136.0	14.0	2.55
	SE100353	140.0	14.0	2.55
	SE100354	150.0	14.0	2.55
	SE100355	160.0	14.0	2.55
	SE100356	170.0	14.0	2.55
	SE100357	180.0	14.0	2.55
	SE100358	190.0	14.0	2.55
	SE100359	200.0	14.0	2.55
	SE100360	210.0	14.0	2.55
	SE100361	220.0	14.0	2.55
	SE055462	230.0	14.0	2.55
	SE100362	240.0	14.0	2.55
NEW	SE100363	250.0	14.0	2.55
NEW	SE114621	255.0	14.0	2.55
	SE100364	260.0	14.0	2.55
	SE100365	270.0	14.0	2.55
NEW	SE114624	275.0	14.0	2.55
	SE100366	280.0	14.0	2.55
	SE100367	300.0	14.0	2.55
	SE055468	310.0	14.0	2.55
NEW	SE114626	330.0	14.0	2.55
	SE100368	350.0	14.0	2.55
	SE100369	360.0	14.0	2.55
	SE100370	400.0	14.0	2.55
	SE055464	410.0	14.0	2.55
	SE100371	420.0	14.0	2.55
	SE100372	430.0	14.0	2.55
	SE100373	450.0	14.0	2.55
NEW	SE100463	463.0	14.0	2.55
	SE100550	480.0	14.0	2.55
NEW	SE114637	500.0	14.0	2.55
	SE055465	510.0	14.0	2.55
	SE100374	520.0	14.0	2.55
	SE100375	530.0	14.0	2.55
	SE055466	610.0	14.0	2.55
	SE100376	620.0	14.0	2.55
	SE100377	630.0	14.0	2.55
	SE100378	640.0	14.0	2.55
	SE055467	650.0	14.0	2.55
NEW	SE114646	710.0	14.0	2.55
NEW	SE114647	810.0	14.0	2.55
NEW	SE114648	1050.0	14.0	2.55



Centerlock™
Also Available

Centrofix™
Also Available

TERMINUS™ PLANER HEAD KNIVES SOLID CARBIDE

	Carbide T10MG	L mm	W mm	T mm
NEW	SE100790	30.0	14.0	2.55
	SE100796	50.0	14.0	2.55
	SE100803	60.0	14.0	2.55
	SE100804	80.0	14.0	2.55
	SE100805	100.0	14.0	2.55
	SE100806	110.0	14.0	2.55
	SE100807	120.0	14.0	2.55
	SE055496	130.0	14.0	2.55
NEW	SE107532	136.0	14.0	2.55
	SE100808	140.0	14.0	2.55
	SE100809	150.0	14.0	2.55
	SE100811	160.0	14.0	2.55
	SE100812	170.0	14.0	2.55
	SE100813	180.0	14.0	2.55
	SE100814	190.0	14.0	2.55
	SE100815	200.0	14.0	2.55
	SE100816	210.0	14.0	2.55
	SE100817	220.0	14.0	2.55
	SE054752	230.0	14.0	2.55
	SE100818	240.0	14.0	2.55
	SE100819	250.0	14.0	2.55
NEW	SE107533	255.0	14.0	2.55
	SE100820	260.0	14.0	2.55
	SE100821	270.0	14.0	2.55
NEW	SE107534	275.0	14.0	2.55
	SE100822	280.0	14.0	2.55
	SE100823	300.0	14.0	2.55
	SE055497	310.0	14.0	2.55
NEW	SE107535	330.0	14.0	2.55
	SE100824	350.0	14.0	2.55
	SE100825	360.0	14.0	2.55
	SE100826	400.0	14.0	2.55
	SE055498	410.0	14.0	2.55
	SE100828	420.0	14.0	2.55
	SE100829	430.0	14.0	2.55
	SE100830	450.0	14.0	2.55
	SE100940	480.0	14.0	2.55
NEW	SE104977	500.0	14.0	2.55
	SE055499	510.0	14.0	2.55
	SE100831	520.0	14.0	2.55
	SE100832	530.0	14.0	2.55
	SE055500	610.0	14.0	2.55
	SE100833	620.0	14.0	2.55
	SE100834	630.0	14.0	2.55
	SE100835	640.0	14.0	2.55
	SE055501	650.0	14.0	2.55



Replacement Knives For Tersa™ Heads



Tersa™



Terminus™



Centerlock™
Also Available



Centrofix™
Also Available

TERSA™ KNIVES HAVE A 10.0MM WIDTH AND THICKNESS OF 2.3MM

REPLACEMENT KNIVES FOR TERSA™ PLANER HEADS

HSS M2 Part #	NEW! HSS M42 Part #	Carbide T10MG	Length
SE100395	SE114539	SE100847	60.0
SE107545	SE114540	SE104212	75.0
SE100396	SE114541	SE100848	80.0
SE107546	SE114542	SE104398	90.0
SE107547	SE114543	SE104211	95.0
SE100397	SE114544	SE055509	100.0
SE100398	SE114545	SE100849	110.0
SE100399	SE114547	SE100851	120.0
SE107548	SE114548	SE104022	125.0
SE100400	SE114549	SE055510	130.0
SE103821	SE114550	SE103823	135.0
SE104613	SE114551	SE104766	140.0
SE107549	SE114552	SE104210	145.0
SE100401	SE114553	SE100852	150.0
SE102716	SE114554	SE103943	160.0
SE100402	SE114555	SE100853	170.0
SE100403	SE114556	SE100854	180.0
SE102774	SE114557	SE105070	185.0
SE104808	SE114558	SE104399	190.0
SE104243	SE114559	SE105698	200.0
SE100404	SE114560	SE100855	210.0
SE104566	SE114561	SE104589	220.0
SE100405	SE114562	SE055511	230.0
SE101718	SE114563	SE103824	235.0
SE101720	SE114564	SE104043	240.0
SE100406	SE114565	SE100856	250.0
SE100407	SE114566	SE100857	260.0
SE104326	SE114567	SE104573	265.0
SE102982	SE114568	SE101673	270.0
SE100408	SE114569	SE100858	280.0
SE100409	SE114570	SE100859	300.0
SE100410	SE114571	SE055512	310.0
SE104686	N/A	N/A	315.0
SE104687	SE114572	SE107550	320.0
SE100411	SE114573	SE100861	330.0

REPLACEMENT KNIVES FOR TERSA™ PLANER HEADS

HSS M2 Part #	NEW! HSS M42 Part #	Carbide T10MG	Length
SE100412	SE114574	SE100862	350.0
SE100413	SE114575	SE100863	360.0
SE100414	SE114576	SE100864	400.0
SE100415	SE114577	SE055513	410.0
SE105267	SE114578	SE107551	415.0
SE100416	SE114579	SE100865	420.0
SE100417	SE114580	SE055514	430.0
SE100418	SE114581	SE100866	450.0
SE100419	SE114582	SE100867	500.0
SE100420	SE114583	SE055515	510.0
SE100421	SE114584	SE055516	520.0
SE100422	SE114585	SE100868	530.0
SE100423	SE114586	SE100869	540.0
SE103994	SE114587	SE104720	600.0
SE100424	SE114588	SE055517	610.0
N/A	N/A	SE055625	625.0
SE100425	SE114589	SE055518	630.0
SE100428	SE114590	SE102179	635.0
SE100426	SE114591	SE100870	640.0
SE100427	SE114592	SE055519	650.0
SE114119	SE114593	N/A	710.0
SE113435	SE114594	N/A	810.0
SE114599	SE114595	N/A	1050.0

T-1 AVAILABLE UPON REQUEST, CALL FOR
AVAILABILITY

Replacement Knives For SuperPac™

SUPERPAC™ KNIVES

BACKING PLATES

Part Number	L mm	W mm	T mm	Part Number T04F	L mm	W mm	T mm	Backing Plate Part #
T10MG								
SE043933	40	38	3.2	SE024082	40	35	7.1	SE024090
SE043934	50	38	3.2	SE043924	50	35	7.1	SE043957
SE043935	60	38	3.2	SE024115	60	35	7.1	SE024123
SE043936	80	38	3.2	SE024148	80	35	7.1	SE024156
SE043937	100	38	3.2	SE023949	100	35	7.1	SE023957
SE043938	120	38	3.2	SE023982	120	35	7.1	SE023990
SE043939	130	38	3.2	SE024016	130	35	7.1	SE024024
SE043940	150	38	3.2	SE024049	150	35	7.1	SE024057
SE043962	170	38	3.2	SE043961	170	35	7.1	SE045837
SE043941	40	50	3.2	SE024093	40	47	7.1	SE024101
SE043942	50	50	3.2	SE043927	50	47	7.1	SE043958
SE043943	60	50	3.2	SE024126	60	47	7.1	SE024134
SE043944	80	50	3.2	SE024159	80	47	7.1	SE024167
SE043945	100	50	3.2	SE023960	100	47	7.1	SE023968
SE043946	120	50	3.2	SE023993	120	47	7.1	SE024001
SE043947	130	50	3.2	SE024027	130	47	7.1	SE024035
SE043948	150	50	3.2	SE024060	150	47	7.1	SE024068
SE043966	170	50	3.2	SE043965	170	47	7.1	SE045838
SE043949	40	60	3.2	SE024104	40	57	7.1	SE024112
SE043950	50	60	3.2	SE043931	50	57	7.1	SE043959
SE043951	60	60	3.2	SE024137	60	57	7.1	SE024145
SE043952	80	60	3.2	SE024170	80	57	7.1	SE024178
SE043953	100	60	3.2	SE023971	100	57	7.1	SE023979
SE043954	120	60	3.2	SE024004	120	57	7.1	SE024012
SE043955	130	60	3.2	SE024038	130	57	7.1	SE024046
SE043956	150	60	3.2	SE024071	150	57	7.1	SE024079
SE043970	170	60	3.2	SE043969	170	57	7.1	SE045839

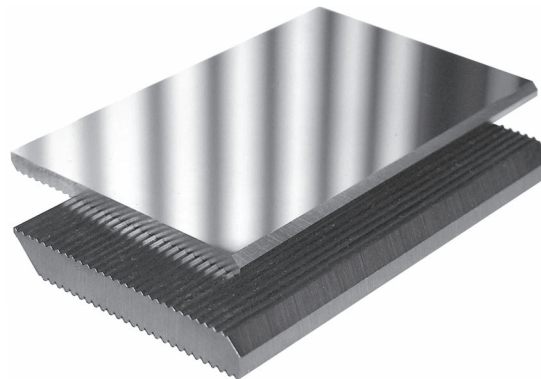

1

2

3

4

5

6

7

8

9

10

Diamond Wheels

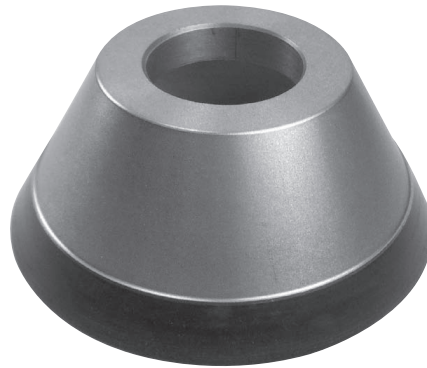

11V9 CUP WHEELS - Cup Wheel USED FOR FACING OR TOP AND SIDE GRINDING

Cincinnati #2 T&C, Deckel, Monosets, K.O. Lee, and Systematic

Part Number	Wheel Diameter	Bore	Degree	Diamond Depth	Grit	Concentration
SE11V9-180	3 3/4"	1 1/4"	60°	1/8"	180	100
SE11V9-400	3 3/4"	1 1/4"	60°	1/16"	400	100

CNC Router Table Pods



Part Number	Description
SERTP110	1 3/4" D x 1" H
SERTP120	1 3/4" D x 1 1/2" H
SERTP130	1 3/4" D x 2" H
SERTP140	1 3/4" D x 2 1/2" H
SERTP150	1 3/4" D x 3" H
SERTP310	3" D x 1" H
SERTP320	3" D x 1 1/2" H
SERTP330	3" D x 2" H
SERTP340	3" D x 2 1/2" H
SERTP350	3" D x 3" H

Carbide-Tipped Saw Blades



Part Number	Diameter	Teeth	Kerf	Bore	Grind
SE972524	7 1/4"	24	.090	5/8"	ATB
SE9840ATB	8 1/4"	40	0.087	5/8"	ATB
SE9860ATB	8 1/4"	60	0.087	5/8"	ATB
SE9128ATB	10"	28	0.118	5/8"	ATB
SE9140ATB	10"	40	0.118	5/8"	ATB
SE9150	10"	50	0.118	5/8"	Combo
SE9160ATB	10"	60	0.118	5/8"	ATB
SE9160TCG	10"	60	0.118	5/8"	TCG
SE9180ATB	10"	80	0.118	5/8"	ATB
SE9240ATB	12"	40	0.118	1"	ATB
SE9260ATB	12"	60	0.118	1"	ATB
*SE9260TCGN	12"	60	0.118	1"	TCG
SE9280ATB	12"	80	0.118	1"	ATB
SE9296ATB	12"	96	0.118	1"	ATB

*Negative Hook

1

2

3

4

5

6

7

8

9

10

Hot New Items



SETA-170



SETA-150

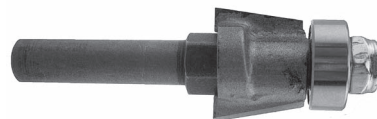

SETA-151

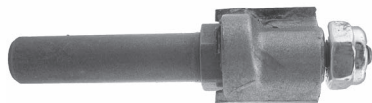

SETA-152



SETA-162



SETA-157

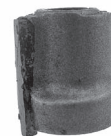

SETA-176

Part Number	Description	
SETA-150	Straight Flush Trim Assembly 1/4" Shank	Sold Each
SETA-151	10° Bevel Trim Assembly 1/4" Shank	Sold Each
SETA-152	Straight Cutter Assembly 1/4" Shank	Sold Each
SETA-156	Straight Slip on Cutters Only	Sold Pkg of 3
SETA-157	10° Bevel Cutters Only	Sold Pkg of 3
SETA-160	Arbors for SETA-150, 151 1/4" Shank	Sold Each
SETA-161	Arbor for SETA-152 1/4" Shank	Sold Each
SETA-162	Arbor for SETA-170 1/4" Shank	Sold Each
SETA-170	Template Bit Assembly 1/4" Shank	Sold Each
SETA-176	Straight Threaded Cutters Only	Sold Pkg of 3
SETA-228	Rabbit Bit Cutter Only	Sold Each
SETA-228K	Rabbit Bit Assembly 1/4" Shank	Sold Each
SETA-Nut	5/16 OD nuts for SETA-150, 151, 152, 228K	Sold Each

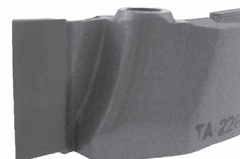

SETA-228



SETA-NUT

HSS M2 Panel Pilot Bits



1 FLUTE STRAIGHT



1 FLUTE SPIRAL

Part Number	Cutting Diameter	Cutting Length	Shank	Overall Length
SE1740	1/4"	3/4"	1/4"	2-3/4"
SE1741	3/8"	3/4"	3/8"	2-3/4"
SE1742	1/2"	1"	1/2"	3-1/8"

Part Number	Cutting Diameter	Cutting Length	Shank	Overall Length
SE1750	1/4"	3/4"	1/4"	3"
SE1751	3/8"	3/4"	3/8"	3"
SE1752	1/2"	1"	1/2"	4-1/4"

Pocket Hole Bits for Castle™ Machine



SE29102-CAST

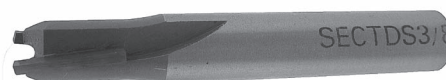

SECTDS-38

Part Number	Cutting Diameter	Cutting Length	Shank	Overall Length	
SE29102-CAST	9/64"	1"	1/4"	2-1/2"	Drill - Package of 5
SECTDS38	3/8"	9/16"	3/8"	2-1/2"	Carbide Tipped
SRU320RUF	3/8"	7/8"	3/8"	2-1/2"	Solid Carbide



SRU320RUF

1

2

3

4

5

6

7

8

9

10

Hot New Items

Carbide-Tipped Picture Frame Bits



SE5812

Part Number	Cutting Diameter	Cutting Length	Overall Length	Shank Diameter
SE5502	3/4"	1-3/16"	2-7/8"	1/4"
SE5504	3/4"	3/4"	2-7/16"	1/4"
SE5506	3/4"	1-7/16"	3-1/8"	1/4"
SE5508	3/4"	1"	2-11/16"	1/4"
SE5810	3/4"	1-3/16"	2-13/16"	1/2"
SE5812	3/4"	1-3/16"	3-1/8"	1/2"
SE5814	3/4"	3/4"	2-11/16"	1/2"
SE5816	3/4"	1-7/16"	3-3/8"	1/2"
SE5818	3/4"	1"	2-15/16"	1/2"
SE5820	3/4"	1-3/16"	3-1/16"	1/2"

SBE115 Bearing



SE5820



SE5814



SE5816



SE5818

Carbide Tipped Euro Step Bits



SE755

Part Number	Large Diameter	Small Diameter	Shank Diameter
SE751	1.000"	0.750"	1/2"
SE753	0.630"	0.500"	1/2"
SE755	0.650"	0.492"	1/2"
SE756	0.630"	0.484"	1/2"
SE757	0.800"	0.563"	1/2"
SE758	0.795"	0.480"	1/2"
SE759	0.638"	0.480"	1/2"

Kreg™ Pocket Hole Jig Bit



SFFB900

Part Number	Description	Diameter	Pilot Drill	Overall Length
SFFB900	Complete Assembly	3/8"	#29	6"
SFFB710	#29 Pilot Drill Only			
SFFB720	Replacement Set Screw			

Easy Edge Bits (No Filing)

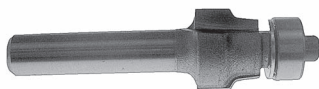

SE2420

Part Number	Cutting Diameter	Cutting Length	Radius	Shank Diameter	Overall Length
SE2420	1/2"	3/8"	1/16"	1/4"	1-7/8"

SBE105 Bearing

Hot New Items

Carbide-Tipped Glue Space Flush Trim Bits

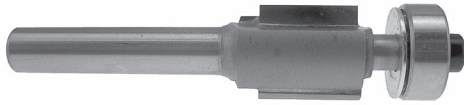

SE2416

Part Number	Cutting Diameter	Cutting Length	Shank Diameter
SE2416	3/8"	1/2"	1/4"
SE2417	3/8"	1"	1/4"
SE2418	1/2"	1/2"	1/4"
SE2419	1/2"	1"	1/4"

SBE115 Bearing

Dodds Dovetail Bits



SE1690

Part Number	Angle	Cutting Diameter	Shank Diameter	Overall Length
SE1690R	9°	.550	5/16"-24	2"
SE1690L	9°	.550	5/16"-24	2"

Solid Surface Repair Set



SE2994

SE2992



Part Number	Description
SE2992	3 Flute Plug Cutter
SE2994	2 Flute Bevel Cutter

If you have ever cut a hole in a piece of solid surface in the wrong place, then you need this set. The bevel bit cuts a taper in the hole that was cut wrong and needs to be repaired. The 3 flute plug cutter cuts a tapered plug that will match the taper from the bevel cutter. Once you have finished you will have a virtually undetectable repair of the solid surface. Effective for repairs up to 1-3/4" in Diameter

Measuring Equipment



SE54-212-012

Part Number
SE54-212-012
SE17906-2

Description
12" Height Gauge
Analog Axial Preset Gauge



SE17906-2

Lubricants

RBL Router Bit Lubricant™



SE-56113-2 2 oz. (12 per Case)
For The Entire Tool & Bearing

OptiCut-NF™



SE-56118 4 oz. (12 per Case)
For Non-Ferrous Metal Cutting

TopSaver Kit



SE-56150
For Table Top Conditioning

ToolSaver Kit

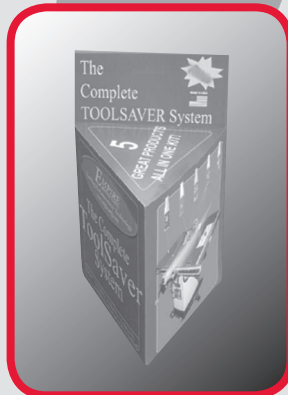

SE-56170
1- Router Bit Lubricant
1- TopSaver
1- OptiCut-XL
1- BladeSaver
1- Dri-Tool

BladeSaver



SE-56160 2 oz (12 per Case)
For Removing Pitch
From Blades & Bits

OptiCut-XL™



SE-56112-2 2 oz. (12 per Case)
For Saw Blades

Grind-Aid



SE-56180 1 gal.
First Aid For Your Grinder



Grind Clean



SE-GCL 1 gal.
Keeps Wheels clean and Aids in
the Grinding Process

Chip Load Charts

These charts are base on **VERY** conservative values

CHIP LOAD BASED ON 2 FLUTE TOOLS

FEED RATE	SPINDLE RPM'S IN THOUSANDS									
	10000	11000	12000	13000	14000	15000	16000	17000	18000	19000
50	0.003	0.002	0.002	0.002	0.002	0.002	0.002	0.001	0.001	0.001
100	0.005	0.005	0.004	0.004	0.004	0.003	0.003	0.003	0.003	0.003
150	0.008	0.007	0.006	0.006	0.005	0.005	0.005	0.004	0.004	0.004
200	0.010	0.009	0.008	0.008	0.007	0.007	0.006	0.006	0.006	0.005
250	0.013	0.011	0.010	0.010	0.009	0.008	0.008	0.007	0.007	0.007
300	0.015	0.014	0.013	0.012	0.011	0.010	0.009	0.009	0.008	0.008
350	0.018	0.016	0.015	0.013	0.013	0.012	0.011	0.010	0.010	0.009
400	0.020	0.018	0.017	0.015	0.014	0.013	0.013	0.012	0.011	0.011
450	0.023	0.020	0.019	0.017	0.016	0.015	0.014	0.013	0.013	0.013
500	0.025	0.023	0.021	0.019	0.018	0.017	0.016	0.015	0.014	0.014
550	0.028	0.025	0.023	0.021	0.020	0.018	0.017	0.016	0.015	0.015
600	0.030	0.027	0.025	0.023	0.021	0.020	0.019	0.018	0.017	0.017

Inches per min.

CONSERVATIVE VALUES IN THE GRAY

CHIP LOAD BASED ON 3 FLUTE TOOLS

FEED RATE	SPINDLE RPM'S IN THOUSANDS									
	12000	13000	14000	14500	15000	16000	17000	18000	18500	19000
100	0.003	0.003	0.002	0.002	0.002	0.002	0.002	0.002	0.002	0.002
150	0.004	0.004	0.004	0.003	0.003	0.003	0.003	0.003	0.003	0.003
200	0.006	0.005	0.005	0.005	0.004	0.004	0.004	0.004	0.004	0.004
250	0.007	0.006	0.006	0.006	0.006	0.005	0.005	0.005	0.005	0.004
300	0.008	0.008	0.007	0.007	0.007	0.006	0.006	0.006	0.005	0.005
350	0.010	0.009	0.008	0.008	0.008	0.007	0.007	0.006	0.006	0.006
400	0.011	0.010	0.010	0.009	0.009	0.008	0.008	0.007	0.007	0.007
450	0.013	0.012	0.011	0.010	0.010	0.009	0.009	0.008	0.008	0.008
500	0.014	0.013	0.012	0.011	0.011	0.010	0.010	0.009	0.009	0.009
550	0.015	0.014	0.013	0.013	0.012	0.011	0.011	0.010	0.010	0.010
600	0.017	0.015	0.014	0.014	0.013	0.013	0.012	0.011	0.011	0.011
650	0.018	0.017	0.015	0.015	0.014	0.014	0.013	0.012	0.012	0.012
700	0.019	0.018	0.017	0.016	0.016	0.015	0.014	0.013	0.013	0.013

Inches per min.

CONSERVATIVE VALUES IN THE GRAY

A RANGE OF .007 TO .012 CHIP LOAD IS IDEAL
 TO LITTLE CHIP LOAD AND YOU BURN UP THE TOOL
 TO HIGH A CHIP LOAD AND YOU BREAK THE TOOL

It is very likely that you will have good results up to 0.017 chip load.

If you would like to calculate your chip load use this formula: Feed Rate in inches per minute divided by RPM's divided by number of cutting edges. Example: Feed Rate of 500in/min divided by 18,000 RPM's divided by 2 (2 flute tool) equals 0.014 chip load.

Find this and other useful tools on our website at www.southeasttool.com

Decimal Equivalents

Diameter	Decimal	Diameter	Decimal	Diameter	Decimal	Diameter	Decimal
1/64"	.0156"	17/64"	.2656"	13.5mm	.5315"	20.5mm	.8071"
1/32"	.0312"	7mm	.2756"	35/64"	.5469"	13/16"	.8125"
1mm	.0394"	9/32"	.2812"	14mm	.5512"	21mm	.8268"
3/64"	.0469"	7.5mm	.2953"	9/16"	.5625"	53/64"	.8281"
1.5mm	.0591"	19/64"	.2969"	14.5mm	.5709"	27/32"	.8438"
1/16"	.0625"	5/16"	.3125"	37/64"	.5781"	21.5mm	.8465"
5/64"	.0781"	8mm	.3150"	15mm	.5906"	55/64"	.8594"
2mm	.0787"	8.2mm	.3228"	19/32"	.5938"	22mm	.8661"
3/32"	.0938"	21/64"	.3281"	39/64"	.6094"	7/8"	.8750"
2.5mm	.0984"	11/32"	.3438"	15.5mm	.6102"	22.5mm	.8858"
7/64"	.1094"	9mm	.3543"	5/8"	.6250"	57/64"	.8906"
3mm	.1181"	23/64"	.3594"	16mm	.6299"	23mm	.9055"
1/8"	.1250"	9.5mm	.3740"	41/64"	.6406"	29/32"	.9062"
3.5mm	.1378"	3/8"	.3750"	16.5mm	.6496"	23.5mm	.9252"
.28	.1405"	25/64"	.3906"	21/32"	.6562"	15/16"	.9375"
9/64"	.1406"	10mm	.3937"	17mm	.6693"	24mm	.9449"
5/32"	.1562"	13/32"	.4062"	43/64"	.6719"	61/64"	.9531"
4mm	.1575"	10.5mm	.4134"	11/16"	.6875"	24.5mm	.9646"
11/64"	.1719"	27/64"	.4219"	17.5mm	.6890"	31/32"	.9688"
4.5mm	.1772"	11mm	.4331"	45/64"	.7031"	25mm	.9843"
3/16"	.1875"	7/16"	.4375"	18mm	.7087"	63/64"	.9844"
5mm	.1969"	11.5mm	.4528"	23/32"	.7188"	1"	1.0000"
5.1mm	.2008"	29/64"	.4531"	18.5mm	.7283"	26mm	1.0236"
13/64"	.2031"	15/32"	.4688"	47/64"	.7344"	28mm	1.1024"
5.5mm	.2165"	12mm	.4724"	19mm	.7480"	30mm	1.1811"
7/32"	.2188"	31/64"	.4844"	3/4"	.7500"	32mm	1.3063"
15/64"	.2344"	12.5mm	.4921"	49/64"	.7656"	34mm	1.3386"
6mm	.2362"	1/2"	.5000"	19.5mm	.7677"	35mm	1.3780"
1/4"	.2500"	13mm	.5118"	25/32"	.7812"	36mm	1.4173"
6.5mm	.2559"	33/64"	.5156"	20mm	.7874"	38mm	1.4961"
6.7mm	.2638"	17/32"	.5313"	51/64"	.7969"	40mm	1.5748"

Formula for transforming metric to decimal

$$(\text{mm} \times .03937 = \text{Decimal})$$

Example: 8mm x .03937 = .315

Formula for transforming decimal to metric

$$(\text{Decimal} \div .03937 = \text{mm})$$

Example: .315 ÷ .03937 = 8mm

Alpha/Numeric Listing

B					
BPD53032LH to BPD5305RH	118				
Basic Set-12	IBC	SCB220 to SCB220LH	1	SE100395 to SE100399	148
Basic Set-14	IBC	SCBP5703LH to SCBP7010RH	119	SE100400 to SE100428	148
C					
CD4502LH to CD53028RH	118	SCD210 to SCD215	1	SE100463	147
CNC Sets	IBC	SCDT7525	21	SE100550	147
CSH20112LH to CSH20510RH	121	SCF200 to SCF205	1	SE100790 to SE100835	147
CSP1604LH to CSP16250RH	121	SCFB100 to SCFB230	1	SE100847 to SE100870	148
D					
DA3502 to DA3505	119	SCHF240 to SCHF244	1	SE100940	147
DACP SCREW	119	SCRS250	1	SE101673 to SE101720	148
Display	IBC	SCRV271 to SCR279	1	SE102179 to SE103994	148
Door Sets	IBC	SCVG260 to SCVG264-212	1	SE10400 to SE10413	55
F					
FBL062-3 to FBL250-3A5	47	SD		SE104022 to SE104808	148
P					
PCO-14	45	SDK500 to SDK510-750	52	SE104977	147
Plastic Set	IBC	SDR187-4 to SDR250-6	47	SE10501 to SE10552	56
PK7000 to PK7012	145	SDR290 to SDR440	52	SE105070 to SE105698	148
PK7014	146	SDR-DRILL to SDR-SCREW	52	SE107545 to SE107551	148
PK7016 to PK7028	145	SDS105 to SDS120	49	SE108000 to SE108810	65
PK7030	146	SE0		SE11 to SE12	
PK7032 to PK7072	145	SE023957 to SE023990	149	SE11125R to SE11437R	96
PK7074	146	SE024001 to SE024178	149	SE113435	148
PK7076 to PK7078	146	SE03508 to SE03520-L	101	SE114119 to SE114599	148
PK7080 to PK7084	146	SE03690-25	112	SE114608 to SE114648	147
PK7086 to PK7098	145	SE03691	101	SE114608 to SE114648	147
PK7102	146	SE03868 to SE03868-916	101	SE11500L to SE11500R	96
PK7104 to PK7106	145	SE03868-L	101	SE116403 to SE116404	95
PK7108	146	SE04008-12 to SE04008-58	104	SE1V9-180 to SE1V9-400	150
PK7110 to PK7128	145	SE04008-NUT	104	SE1201 to SE1270	15
PKC7001 to PKC7073	145	SE04010-1 to SE04010-78	104	SE12000-CMS	106
PKC7075	146	SE04018	105	SE12040	106
PKC7077 to PKC7079	146	SE04018-TWA	112	SE12105R to SE12108R	68
PKC7081 to PKC7085	145	SE04205 to SE04213	103	SE12213-W-50 to SE12407-W	106
PKC7087 to PKC7101	145	SE04216-7mm to SE04216-932	103	SE12700-40 to SE12700-100	110
PKC7103	146	SE04220-7mm to SE04220-932	103	SE13	
PKC7105 to PKC7107	145	SE04225-7mm to SE04225-932	103	SE1300 to SE1304	16
PKC7109	146	SE04232-5mm to SE04232-932	103	SE1370 to SE1376B	17
Q					
QCDA1001RH to QCDA8006LH	120	SE04240-1 to SE04240-932	103	SE13001M to SE13104	68
QCDA-Biesse	120	SE043933 to SE043970	149	SE13201L to SE13302R	69
QCDA-Morbideli	120	SE04576 to SE04580-20	112	SE13501 to SE13913	69
QCDA-Screw	120	SE045837 to SE045839	149	SE136401 to SE136404	95
QCHDA250	121	SE04587 to SE046505-40	112	SE13001 to SE13019	109
R					
RB41250	128	SE04608 to SE4624	105	SE13937 to SE131000	16
SA					
SAR250 to SAR500-1716	47	SE04889 to SE04898	107	SE14	
SARF250 to SARF500-XL3	47	SE05024-001 to SE05024-136	108	SE1402 to SE1404	17
SARJM250 to SARJM500	47	SE054752 to SE055501	147	SE1404B	18
SB					
SBE100 to SBE115	49	SE055509 to SE055625	148	SE1405 to SE1406B	17
SBE115-ES	49	SE06000-2016M to SE06115	106	SE1406BB	18
SBE117 to SBE140	49	SE061BT353276	106	SE1406C to SE1420	17
SBE140-ES	49	SE07703 to SE07711	111	SE1425 to SE1436	18
SBE145 to SBE200	49	SE07801 to SE07814	109	SE1440 to SE1440B	19
SBESS	49	SE10		SE1450 to SE1464	18
SBK022	49	SE1004 to SE1030	13	SE1474 to SE1480	19
SBNU125 to SBNU750	12	SE1031 to SE1033	14	SE14002R to SE14031R	70
SBPT1 to SBPT1T	54	SE1033A	13	SE14100L to SE14105R	74
		SE1035 to SE1036	13	SE14106L to SE14116R	75
		SE1039 to SE1043	14	SE14117L to SE14125R	71
		SE1049 to SE1055C	13	SE14126L to SE14132R	72
		SE1058 to SE1095A	14	SE14135L to SE14140R	73
		SE1095B to SE1107	15	SE14141L to SE14146R	74
		SE1014LH to SE1107LH	15	SE14147L to SE14156R	76
		SE1000TBU	128	SE14200L to SE14200R	73
		SE100297 to SE100378	147		

Alpha/Numeric Listing

SE14	SE20	SE29
SE14201L to SE14210R	72 SE200TH	112 SE2970 to SE2974
SE14211L to SE14216L	70 SE2000 to SE2005A	24 SE2986 to SE2990
SE14217L to SE14222R	73 SE2005ADS	32 SE2992 to SE2994
SE14400 to SE14403	55 SE2006	24 SE29001 to SE29032
SE141001L to SE141002R	74 SE2006DS	32 SE29002L to SE29007L
SE141022L to SE141053R	75 SE2007	24 SE29008L to SE29032L
SE141073R to SE141109R	76 SE2007DS	32 SE29102-CAST
SE141111L to SE141141R	75 SE2008	24 SE29101 to SE29133
SE141170L to SE141231R	71 SE2008DS	32 SE29201 to SE29225F
SE141401L to SE141451R	74 SE2009 to SE2009B	24 SE29501 to SE29508
SE142031L to SE142064R	73 SE2009ADS	32 SE295005 to SE295075
SE142071R to SE142098R	72 SE2010	24 SE295085 to SE2950125
SE144000 to SE14030	55 SE2010DS	32 SE29827 to SE29828
SE141010L to SE1410800R	75 SE2011 to SE2016	
SE1410931	76 SE2034 to SE2037	SE30 to SE39
SE1411021L to SE1411104R	75 SE2050 to SE2066	SE3000TH
SE1412201L to SE1412301R	71 SE2068 to SE2078	112 SE3000 to SE3052
SE1414001L to SE1414006R	74 SE20002 to SE20044	29 SE3070 to SE3098
SE1420703L to SE1420703R	73 SE20100 to SE20120	30 SE30000 to SE30005
SE15	SE20121 to SE20203HS	107 SE30078 to SE30375
SE1501 to SE1526	82 SE20601 to SE20618	90 SE3100 to SE3114
SE1541 to SE1598	83 SE20601HS to SE20618HS	30 SE3160 to SE3196
SE15101 to SE15203	84 SE20701 to SE201011	35 SE31078 to SE31375
SE15301 to SE15335	81 SE201022	107 SE31374-60
SE15401 to SE15434	82 SE201031 to SE201050	35 SE3200 to SE3204
SE15501HS to SE15697HS	81 SE201051 to SE201081	36 SE3205 to SE3258
SE15701 to SE15804	82 SE201101 to SE201121	41 SE3265 to SE3266
SE15901 to SE15905	81 SE201122	37 SE3273 to SE3281
SE151032 to SE152011	82 SE201142 to SE201202	36 SE3282
SE153001 to SE153002	81 SE201221	37 SE3284 to SE3296
SE154273 to SE154274	82 SE203050HS to SE203122HS	39 SE3350 to SE3370
SE155004HS to SE155006HS	80 SE207098	41 SE3375
SE157012 to SE158012	SE21 to SE28	46 SE3375G
SE159012	SE2160 to SE2164RH	41 SE3385
	SE21225 to SE21240	109 SE33108 to SE33125-L
SE16 to SE18	SE2200 to SE2298	49 SE348-14
SE1601 to SE1674	SE22220	41 SE3525
SE1690L to SE1690R	26 SE2300 to SE2306	42 SE3601 to SE3608
SE1700 to SE1706	27 SE2307 to SE2309	42 SE3719 to SE3752
SE1725 to SE1726	26 SE2310	
SE1740 to SE1752	27 SE2315	SE40 to SE49
SE17105-00801 to SE17105-00802	109 SE23108 to SE23125	SE40050 to SE41025
SE17906-2	27 SE2400 to SE2410	110 SE41060 to SE41087
SE1800 to SE1810	31 SE2410DS	109 SE4403502
SE18402 to SE18412	155 SE2416 to SE2419	64 SE46001HS to SE46004HS
SE18800 to SE188002	154 SE2420	104 SE46111 to SE46140
	28 SE2425 to SE2470	
SE19	27 SE2500 to SE2505	SE50 to SE54
SE1900 to SE1980	30 SE2530 to SE2538	SE50001
SE19001 to SE19030	92 SE26115 to SE26165	107 SE50134 to SE50135
SE19100 to SE19116	94 SE2646809 to SE2647017	58 SE50136HS to SE50215
SE19101L to SE19112L	100 SE280003 to SE280024	61 SE50216 to SE50218
SE19201 to SE19210	SE29	58 SE50219
SE19995	SE2900 to SE2914	61 SE50220 to SE50221
SE191002 to SE191161	31 SE2921 to SE2924	58 SE50222
SE192051 to SE192091	33 SE2926	61 SE50223 to SE50225
SE1911101 to SE1911441	31 SE2927 to SE2928	58 SE50226 to SE50228
SE1920301 to SE1920914	32 SE2930 to SE2935	59 SE50300BP to SE50305BPHS
	31 SE2940 to SE2958	58 SE50701HS to SE50806
	33 SE2960 to SE2968	58 SE503010 to SE503025
		49 SE540-14 to SE540-38

Alpha/Numeric Listing

SE55 to SE59

SE5502 to SE5508	154
SE55001 to SE55033	99
SE-56126	34
SE5610 to SE5620	42
SE56401 to SE56404	95
SE5710 to SE5725	42
SE5703LH to SE57625RH	115
SE5801 to SE5805	43
SE5810 to SE5820	154
SE5900B to SE5952	43

SE60 to SE69

SE60TH	112
SE6000G	46
SE6001 to SE6016	44
SE6019 to SE6023	40
SE6024 to SE6026	44
SE6045 to SE6050	45
SE60001HS to SE600014HS	64
SE6100 to SE6100F	54
SE6390 to SE6403	48
SE63505LH to SE635250RH	116
SE6405043-224 to SE6405043-225	108

SE70 to SE89

SE750-19	109
SE750TBU	128
SE751 to SE759	154
SE7003LH to SE70375RH	115
SE7010LH to SE7025RH	116
SE74003 to SE74005	97
SE76104 to SE76404	95
SE7704LH to SE7712RH	116
SE80200 to SE80209	66
SE80210 to SE80218	65
SE802041 to SE802061	66
SE8505002 to SE8905003	107

SE90

SE90001 to SE90022	67
SE918 to SE946	121
SE9128ATB to SE9296ATB	151
SE94620 to SE94732	99
SE9500	48
SE9600	51
SE96401 to SE96404	95
SE971125N	48
SE972524	151
SE972531 to SE976575	48

SEA to SEC

SEA250175 to SEA251775	93
SE-BBP	128
SE-BCS	127
SEBE2000 to SEBE2016	25
SE-BRP to SE-BRS	127
SE-BRPT	128
SECB250 to SECB1000	111
SECB-34 to SECB-34HS	50
SECR500LH to SECR1000RH	51
SECS1431R	124

SEC

SECSRB-1 to SECSRB-212	50
SECTDS38	14
SED to SEH	
SEDC32-14 to SEDC32-58	111
SEDL12 to SEDL12-F	98
SEDOOR-53 to SEDOOR-60T	98
SE-E12 to SE-E25	49
SEHB5715LH to SEHB5719RH	117
SEHB5720LH to SEHB5740RH	118
SEHB7015LH to SEHB7040RH	118
SEHK-116 to SEHK564	49
SEHMA-14 to SEHMA-12-XXL	16
SEHMC250 to SEHMC750	50
SEHN-24mm-.187 to SEHN-24mm-20	104
SEHN-29mm-.187 to SEHN-29mm-.750	104
SEHN-Piggyback-14 to SEHN-Piggyback-58	104
SEHSSRB-34 to SEHSSRB-3	50

SEI

SEIBCS	126
SE-IBP	128
SEIBRP-34	126
SEIBSS	126
SEIBSSFD	125
SEIBCSFD	125
SEIBT22-14 to SEIBT22-12	124
SE-ICSB	126
SE-ICSBFD	125
SE-ICSO	127
SE-ICSOFD	125
SE-ICSR	127
SE-ICSRFD	125
SEID218	98
SEIFT-71212 to SEIFT75012	123
SEINS-1-30	123
SEINS22-40 to SEINS22-50	124
SEINS-34-12 to SEINS-34-58	123
SE-IRPC to SE-IRSR	126
SEIS2-740 to SEIS2-750	123
SEI-SCREW	135
SEISI-73012 to SEISI-74012	123
SEISO-30-THERM	106
SEIT750-30 to SEIT-1125-50	123
SEIV90-12 to SEIV91-12	123

SEJ to SESC

SEJS13M to SEJS49MET	87
SELC-18 to SELC-12	49
SELC-SCREW	49
SEM2-1250-14 to SEM2-3000-516	136
SEM2C-14-1250 to SEM2C-516-3000	136
SEMH422ST to SEMH669ST	137
SENTS-54300130 to SENTS-54300130-L	106
SENTS-BT30-38 to SENTS-ISO30-47	110
SEPD125LH to SEPD375RH	51
SEPE30DM20 to SEPE30DF2056	106
SEPSS-30BT to SEPSS-50	112
SERC500LH to SERC750RH	51
SERTP110 to SERTP350	150
SESC-14 to SESC-1	96

SESD to SEW

SESD516 to SEDS1000	91
SESD-20mm-.250 to SEDS-20mm-NUT	102
SESD-C001-.125 to SEDS-C001-NUT	102
SESD-C015-.125 to SEDS-C015-NUT	102
SESK-012	49
SESP-44-416 to SESPM-69-660	135
SESS-22-14 to SESS-22-NUT	102
SESS22TWA	112
SE-T8	135
SETA-150 to SETA-NUT	153
SETSM1005LH to SETSM8015RH	119
SEV5803LH to SEV58500RH	116
SEV5813LH to SEV7712RH	117
SEWH-316-2000 to SEWH-14-2500C	136

SF

SFFB700 to SFFB900	54
SFTD200 to SFTD265	5
SFTU120 to SFTU165	5
SFTUD555	5

SI

SI-1001322 to SI-10510515	129
SI-117815	131
SI-1201322	129
SI-121215	129
SI-125511BG	130
SI-131215 to SI-14614625CR	129
SI-151215	129
SI-151520CB	131
SI-151525	129
SI-151525BYRD to SI-151525-SQ-SP	129
SI-152370-224 to SI-152773-241	134
SI-1580WRENCH	135
SI-1717203 to SI-1959015	129
SI-197815	131
SI-201215	129
SI-201215AL to SI-201215AR	130
SI-201215CB	131
SI-205511BG	130
SI-205511BCG to SI-205511FG4	131
SI-212155	129
SI-25100WRENCH	135
SI-251215 to SI-251215-2	129
SI-25511FG4	131
SI-287015	130
SI-2951015 to SI-2951115	130
SI-2951215	130
SI-2951215SP to SI-2959015SP	130
SI-301215 to SI-301215-16	129
SI-301215AL to SI-301215-TL15	130
SI-301215CB	131
SI-301402LH to SI-301402RH	133
SI-305511BG	130
SI-305511BCG to SI-305511FG4	131
SI-351215	129
SI35-SCREW	135
SI-3951215	130
SI-3951215V	133

Alpha/Numeric Listing

SI	SR	109000 to 110000
SI4-SCREW	135 SRD202 to SRD220	6 109391 to 109451 140
SI-401215	129 SRD220MD	10 109452 to 111218 141
SI-401215AL to SI-401215AR	130 SRD223 to SRD235	6 111225 to 111271 140
SI-405511BG	130 SRD235MD	10 111272 to 111287 141
SI-405511BCG to SI-405511FG4	131 SRD237	6 111288 to 111361 139
SI-4951015 to SI-4951115	130 SRD237MD	10 111362 to 111367 140
SI-4951215 to SI-501017	130 SRD245 to SRD255	6 111368 to 111372 139
SI-501215	129 SRD255MD	10 111373 to 111378 140
SI-501215AL to SI-505511BG	130 SRD260	6 111379 to 111383 139
SI-501215CB	131 SRD260MD	10 111384 to 111389 140
SI-505511BCG to SI-505511FG4	131 SRD263 to SRD265	6 111691 to 111720 141
SI-505511BG-T03	130 SRD265MD	10
SI-508015FG	131 SRD267 to SRD297	6 112000 to 114000
SI-5951215	130 SRD420RUF to SRD645SLRUF	7 112629 to 112657 139
SI-601215	129 SRD702SL to SRD745SL	8 112658 to 112667 140
SI-608015FG	131 SRD823FIN to SRD846FIN	11 112668 to 112671 141
SI-751215 to SI-961215	129 SRU102 to SRU120	6 112672 to 112675 142
SI-978152	131 SRU120MD	10 113812 to 113875 139
SI-SCREW10-32X6 to SI-SCREW10-32X9	135 SRU123 to SRU135	6 114136 to 114271 142
SICS-SCREW	135 SRU135MD	10 114272 to 114393 143
SIDR-161752-2 to SIDR-161752-5	132 SRU137 to SRU155	6 114394 to 114406 144
SIGSH-SCREW	135 SRU155MD	10 114408 to 114476 141
SILS-308015 to SILS-2478015	132 SRU160	6
SIPP-565511 to SIPP-1025511	132 SRU160MD	10
SIR-121802-2LH to SIR-121802-3RH-MFA	134 SRU163 to SRU165	6
SIR-151452L-2 to SIR-1961522R-2	131 SRU165MD	10
SIRP-12712732-2 to SIRP-12712732-3	132 SRU167 to SRU197	6
SISG-141420-2 to SISG-341670	133 SRU320RUF to SRU545SLRUF	7
SISP-185735	133 SRU602SL to SRU648SL	8
SIS-SCREW	135 SRU723FIN to SRU746FIN	11
SITS-221920	133	
SI-WRENCH	135	
	SS to SU	
	SST100 to SST130	4
	SST195 to SST198	1
	SST200 to SST280	5
	STB310 to STB648	138
	STBNU125-1 to STBNU250-7	12
	STOP060 to STOP180	47
	SUD448 to SUD553A	8
	SUD554 to SUD594	9
	SUD448CB to SUD594CB	9
	SUD750 to SUD888	11
	SUD950FIN to SUD990FIN	12
	107000	
	107257 to 107363	140
	107364 to 107381	141
	107383 to 107397	140
	107398 to 107415	141
	107417 to 107431	140
	107432 to 107451	141
	107452	142
	107453	141
	107454	142
	107455	141
	107456 to 107464	142
	107465	141
SJ to SP		
SJM187-4 to SJM281-6	47	
SKN6256 to SKN7508	45	
SL050-3 to SL0281-4A5	46	
SLASCA	48	
SLAT670 to SLAT820	54	
SLD400 to SLD470	8	
SLIN062	12	
SLOC600 to SLOC610	53	
SLU300 to SLU370	8	
SLUD598 to SLUD696	10	
SMDUD550 to SMDUD573	10	
SMDUD750 to SMDUD790	11	
SMS300 to SMS460-34	53	
SOD200 to SOD260	2	
SOD402 to SOD823	3	
SOU100 to SOU160	2	
SOU300 to SOU948	3	
SPL100 to SPL232	2	
SPOIL178-2 to SPOIL-WRENCH	125	
SPOU100 to SPOU120	4	
SPR200 to SPR420	4	
SPS2-16-095 to SPSARBOR-34	4	

Router Bit Sets



Door Set

SE5900E
Round Raised Panel Bit

SE6001
Stile and Rail Bit



Basic Set-12

SE1067
1/2" Straight Bit

SE1504
3/4" V-Groove Bit

SE1803
1/4" Radius Cove

SE1901
1 1/4" Rabbet Bit

SE2006
1/4" Radius Roundover

SE2009
1/2" Radius Roundover

SE2202
5/32" Radius Roman
Ogee

SE2305
45 Degree Chamfer Bit

SE2405
1/2" Trim Bit



CNC Set

SRU120
1/4" S/C Spiral Upcut

SRD220
1/4" S/C Spiral Downcut

SRU165
1/2" S/C Spiral Upcut

SRD265
1/2" S/C Spiral Downcut

SUD555
S/C 1/2" Dia x 1 1/4"
CL Compression

SUD573
S/C 1/2" Dia x 2"
CL Compression

SE1507
C/T 1 1/2" Dia V Groove Bit

SE5610
C/T MDF Bit-Bead

SE5710
C/T MDF Bit-Cove



P Set

SRU120
1/4" S/C Spiral Upcut

SPL100
1/8" S/C Straight O Flute

SPL110
3/16" S/C Straight O Flute

SPL120
1/4" S/C Straight O Flute

SPL220
1/4" S/C Straight O Flute
2 Flute

SOU100
1/8" S/C Spiral O Flute

SOU120
1/4" S/C Spiral O Flute

SPOU120
1/4" S/C Multi Grind
Polished O Flute

SPR200
1/8" Radius O Flute
1/8" Material

SPR220
1/4" Radius O Flute
1/4" Material



**Displays
now available!**



**Packaging
now available!**





VOLUME 10

USPS/Mail Address

PO Box 1597
Conover, NC 28613

UPS/Fed Ex

101 GE Plant Road SW
Conover, NC 28613
Toll Free: 877.465.7012
Fax: 866.945.9433

Southeast-West Coast

Portland, OR 97230
Phone: 503.256.1528
Fax: 503.256.1641

Southeast-Canada

Cambridge, ON N1T 1H9
Phone: 519.623.8150
Fax: 519.623.8331

Email: Router@SouthEastTool.com

Web: www.SouthEastTool.com

Send email orders to:
Orders@SouthEastTool.com

Distributed By: